

# OrCAD<sup>®</sup> Schematic Design Tools Reference Guide

# *Schematic Design Tools*

## *Reference Guide*

---

OrCAD/SDT

V 4.10

Customer Registration Number:

6034134





*Electronic Design Automation Tools*

*Schematic Design Tools*

*Reference Guide*

---

Copyright © 1991 OrCAD L.P. All rights reserved.

No part of this publication may be reproduced, translated into another language, stored in a retrieval system, or transmitted, in any form or by any means, electronic, mechanical, photocopying, recording, or otherwise without the prior written consent of OrCAD L.P.

Every precaution has been taken in the preparation of this publication. OrCAD assumes no responsibility for errors or omissions. Neither is any liability assumed for damages resulting from the use of the information contained herein.

OrCAD<sup>®</sup> is a registered trademark of OrCAD L.P.

IBM<sup>®</sup> is a registered trademark of International Business Machines Corporation.

HP-GL<sup>®</sup> is a registered trademark of Hewlett-Packard Company.

VersaCad<sup>®</sup> is a registered trademark of VersaCad Corporation.

Postscript<sup>®</sup> is a registered trademark of Adobe Systems Incorporated.

All other brand and product names mentioned herein are used for identification purposes only, and are trademarks or registered trademarks of their respective holders.

Document Number: OR9063C 8-23-91



3175 NW Aloclek Drive

Hillsboro, Oregon 97124-7135

U.S.A.

|                               |                |
|-------------------------------|----------------|
| Sales & Administration        | (503) 690-9881 |
| Technical Support             | (503) 690-9722 |
| 24-Hour Bulletin Board System | (503) 690-9791 |
| FAX                           | (503) 690-9891 |

# C O N T E N T S

---

|  |        |
|--|--------|
| Preface .....                                | xxxi   |
| Tools and tool sets .....                    | xxxi   |
| Editors .....                                | xxxii  |
| Processors .....                             | xxxiii |
| Librarians .....                             | xxxiii |
| Reporters .....                              | xxxiii |
| Transfers .....                              | xxxiii |
| User buttons .....                           | xxxiv  |
| Mouse techniques .....                       | xxxiv  |
| Keyboard equivalents .....                   | xxxv   |
| About this guide .....                       | xxxv   |
| Part I: Configuration .....                  | 1      |
| Chapter 1: Configure Schematic Tools .....   | 3      |
| Display the Configure Schematic Design ..... | 5      |
| Tools screen .....                           | 5      |
| Driver Options .....                         | 6      |
| Driver Prefix .....                          | 7      |
| Available Display Drivers .....              | 8      |
| Available Printer Drivers .....              | 9      |
| Available Plotter Drivers .....              | 10     |
| Printer/Plotter Output Options .....         | 11     |
| Library Options .....                        | 12     |
| Library Prefix .....                         | 13     |
| Inserting a library .....                    | 14     |
| Removing a library .....                     | 14     |
| Changing the library order .....             | 15     |
| Types of libraries .....                     | 15     |
| Active library .....                         | 16     |
| On-line library .....                        | 16     |
| Active library size .....                    | 18     |
| Worksheet Options .....                      | 19     |
| Default worksheet file extension .....       | 24     |
| Sheet size .....                             | 24     |
| Document number .....                        | 24     |
| Revision .....                               | 24     |

|   |    |
|---|----|
| Title.....  | 24 |
| Organization name.....                                  | 24 |
| Organization address.....                               | 24 |
| Macro Options.....                                      | 25 |
| Macro Buffer Size.....                                  | 25 |
| Draft Macro File and Edit Library Macro File.....       | 26 |
| Draft Initial Macro and Edit Library Initial Macro..... | 26 |
| Hierarchy Options.....                                  | 27 |
| Hierarchy Buffer Size.....                              | 27 |
| Color and Pen Plotter Table.....                        | 28 |
| Color.....  | 28 |
| Pen.....  | 28 |
| Width.....  | 30 |
| Speed.....  | 30 |
| 1st Part Field through 8th Part Field.....              | 31 |
| Template Table.....                                     | 32 |
| Units.....  | 33 |
| Horizontal.....   | 33 |
| Vertical.....   | 33 |
| Pin-to-Pin.....   | 33 |
| Pin Number.....   | 34 |
| Pin Name.....   | 34 |
| Part Reference.....                                     | 34 |
| Part Value.....   | 34 |
| 1st Part Field through 8th Part Field.....              | 34 |
| Power Text.....   | 34 |
| Sheet Name.....   | 34 |
| Sheet Net.....  | 34 |
| Module Text.....  | 34 |
| Label.....  | 34 |
| Comment Text.....                                       | 35 |
| Title Block.....  | 35 |
| Border Text.....  | 35 |
| X Border Width, Y Border Width.....                     | 35 |
| Plot X Offset.....                                      | 35 |
| Plot Y Offset.....                                      | 35 |
| Roll Form Size.....                                     | 35 |

---

|  |    |
|--|----|
| Spacing Ratio.....                         | 36 |
| Key Fields.....                            | 37 |
| Annotate Schematic Part Value Combine..... | 40 |
| Update Field Contents Combine for .....    | 43 |
| Create Netlist Part Value Combine.....     | 45 |
| Create Netlist.....                        | 45 |
| Create Bill of Materials.....              | 46 |
| Create Bill of Materials.....              | 46 |
| Extract PLD.....                           | 47 |
| Check Electrical Rules Matrix.....         | 50 |
| Part II: Editors .....                     | 53 |
| Chapter 2: Draft .....                     | 55 |
| Execution .....                            | 55 |
| Local Configuration .....                  | 56 |
| File Options .....                         | 56 |
| Processing Options .....                   | 57 |
| Command reference.....                     | 58 |
| Selecting commands .....                   | 58 |
| Locating commands .....                    | 58 |
| AGAIN.....                                 | 61 |
| BLOCK.....                                 | 62 |
| BLOCK Move .....                           | 63 |
| BLOCK Drag.....                            | 64 |
| BLOCK Fixup.....                           | 64 |
| BLOCK Get .....                            | 65 |
| BLOCK Save.....                            | 66 |
| BLOCK Import .....                         | 67 |
| BLOCK Export.....                          | 68 |
| BLOCK ASCII Import.....                    | 69 |
| BLOCK Text Export.....                     | 70 |
| CONDITIONS.....                            | 71 |
| Worksheet Memory Size.....                 | 71 |
| Hierarchy Buffer.....                      | 72 |
| Macro Buffer.....                          | 72 |
| Active Library.....                        | 72 |



|  |     |
|--|-----|
| Reference Library .....                        | 72  |
| DELETE .....                                   | 73  |
| DELETE Object.....                             | 73  |
| DELETE Block .....                             | 74  |
| DELETE Undo.....                               | 74  |
| EDIT.....                                      | 75  |
| Editing techniques .....                       | 75  |
| Editing labels.....                            | 76  |
| Editing module ports.....                      | 77  |
| Editing power objects .....                    | 78  |
| Editing sheet symbols.....                     | 79  |
| Editing parts.....                             | 82  |
| Editing the title block.....                   | 88  |
| Editing stimulus objects.....                  | 90  |
| Editing trace objects.....                     | 90  |
| Editing vector objects .....                   | 90  |
| Editing layout objects.....                    | 90  |
| FIND.....                                      | 91  |
| GET .....                                      | 93  |
| Getting a part by entering a part suffix ..... | 94  |
| The outline symbol .....                       | 94  |
| Rotating and placing parts .....               | 95  |
| HARDCOPY.....                                  | 97  |
| HARDCOPY Destination.....                      | 98  |
| HARDCOPY.....                                  | 99  |
| HARDCOPY Make Hardcopy.....                    | 99  |
| HARDCOPY.....                                  | 99  |
| INQUIRE .....                                  | 100 |
| JUMP .....                                     | 101 |
| JUMP A, B, C, D, E, F, G, H Tag.....           | 101 |
| JUMP Reference .....                           | 101 |
| JUMP X-Location.....                           | 102 |
| JUMP Y-Location.....                           | 103 |
| LIBRARY .....                                  | 104 |
| LIBRARY Directory.....                         | 104 |
| LIBRARY Browse .....                           | 105 |
| MACRO.....                                     | 106 |

---

|                                 |     |
|---------------------------------|-----|
| MACRO Capture .....             | 107 |
| MACRO Delete .....              | 110 |
| MACRO Initialize.....           | 110 |
| MACRO List.....                 | 110 |
| MACRO Read.....                 | 110 |
| MACRO Write .....               | 111 |
| Using macros.....               | 111 |
| Macro text files.....           | 112 |
| Middle mouse button macros..... | 115 |
| Creating efficient macros.....  | 117 |
| PLACE.....                      | 118 |
| PLACE Wire.....                 | 118 |
| PLACE Bus .....                 | 120 |
| PLACE Junction.....             | 121 |
| PLACE Entry (Bus) .....         | 122 |
| PLACE Label.....                | 123 |
| PLACE Module Port.....          | 125 |
| PLACE Power .....               | 127 |
| PLACE Sheet.....                | 129 |
| PLACE Text.....                 | 131 |
| PLACE Dashed Line.....          | 132 |
| PLACE Trace Name.....           | 133 |
| PLACE Vector.....               | 134 |
| PLACE Stimulus .....            | 135 |
| PLACE NoConnect .....           | 137 |
| PLACE Layout.....               | 138 |
| QUIT.....                       | 141 |
| QUIT Enter Sheet.....           | 141 |
| QUIT Leave Sheet.....           | 141 |
| QUIT Update File.....           | 142 |
| QUIT Write to File .....        | 142 |
| QUIT Initialize.....            | 142 |
| QUIT Suspend to System.....     | 143 |
| QUIT Abandon Edits.....         | 143 |
| QUIT Run User Commands.....     | 144 |
| REPEAT.....                     | 145 |
| SET.....                        | 146 |

|  |     |
|--|-----|
| SET Auto Pan.....                                  | 147 |
| SET Backup File.....                               | 147 |
| SET Drag Buses.....                                | 148 |
| SET Error Bell.....                                | 148 |
| SET Left Button.....                               | 148 |
| SET Macro Prompts.....                             | 149 |
| SET Orthogonal.....                                | 149 |
| SET Show Pin Numbers.....                          | 150 |
| SET Title Block.....                               | 150 |
| SET Worksheet Size.....                            | 151 |
| SET X,Y Display.....                               | 151 |
| SET Grid Parameters.....                           | 152 |
| SET Repeat Parameters.....                         | 153 |
| SET Visible Lettering.....                         | 154 |
| TAG.....   | 155 |
| ZOOM.....  | 156 |
| ZOOM Center.....                                   | 156 |
| ZOOM In.....                                       | 156 |
| ZOOM Out.....                                      | 156 |
| ZOOM Select.....                                   | 156 |
| Chapter 3: Guidelines for creating designs.....    | 157 |
| Label names.....                                   | 157 |
| Wire labels.....                                   | 157 |
| Bus labels.....                                    | 158 |
| Multiple labels on a bus.....                      | 160 |
| Combining labels.....                              | 160 |
| Intersheet connections.....                        | 161 |
| Splitting buses.....                               | 163 |
| Handling and isolating power.....                  | 164 |
| Connecting power objects with different names..... | 166 |
| Connecting power objects to a module port.....     | 167 |
| Handling power in a hierarchy.....                 | 168 |
| Example of isolating power: battery backup.....    | 168 |
| Handling physical connectors.....                  | 172 |
| Chapter 4: Edit File.....                          | 173 |
| About Edit File.....                               | 173 |

---

|   |     |
|---|-----|
| Execution .....                             | 173 |
| Chapter 5: View Reference.....              | 175 |
| About View Reference.....                   | 175 |
| Execution .....                             | 175 |
| Part III: Processors.....                   | 177 |
| Chapter 6: Annotate Schematic.....          | 179 |
| Execution .....                             | 179 |
| Running Annotate Schematic.....             | 179 |
| Key fields.....                             | 180 |
| Before annotation and after annotation..... | 180 |
| Local Configuration .....                   | 182 |
| Chapter 7: Back Annotate .....              | 185 |
| Execution .....                             | 185 |
| Local Configuration .....                   | 186 |
| Chapter 8: Cleanup Schematic .....          | 189 |
| Execution .....                             | 189 |
| Local Configuration .....                   | 191 |
| Chapter 9: Creating a netlist.....          | 193 |
| Incremental design.....                     | 193 |
| Compile: INET .....                         | 194 |
| Link: ILINK .....                           | 194 |
| Format:.....                                | 194 |
| The compiler: INET.....                     | 196 |
| The incremental connectivity database.....  | 196 |
| The  LINK command.....                      | 197 |
| The linker: ILINK.....                      | 198 |
| Intermediate netlist structure.....         | 199 |
| The linked connectivity database.....       | 199 |
| The flat formatter: IFORM.....              | 200 |
| The hierarchical formatter: HFORM.....      | 200 |
| Caveats.....                                | 201 |

|  |     |
|--|-----|
| Chapter 10: Create Netlist.....                          | 203 |
| Linked format.....                                       | 203 |
| Execution .....  | 204 |
| Local Configuration of Create Netlist.....               | 205 |
| Local Configuration of INET .....                        | 207 |
| Local Configuration of ILINK.....                        | 211 |
| Local Configuration of IFORM.....                        | 213 |
| Chapter 11: Create Hierarchical Netlist .....            | 215 |
| Hierarchical format.....                                 | 215 |
| Execution .....  | 216 |
| Local Configuration of Create Hierarchical Netlist ..... | 217 |
| Local Configuration of INET .....                        | 218 |
| Local Configuration of HFORM .....                       | 222 |
| Chapter 12: Select Field View .....                      | 225 |
| Execution .....  | 225 |
| Local Configuration .....                                | 225 |
| Chapter 13: Update Field Contents .....                  | 229 |
| Execution .....  | 229 |
| Local Configuration .....                                | 231 |
| Part IV: Librarians.....                                 | 235 |
| Chapter 14: About libraries.....                         | 237 |
| Library files.....                                       | 237 |
| Library source file .....                                | 238 |
| Compiled library file.....                               | 238 |
| List parts in a library.....                             | 239 |
| Creating library files .....                             | 239 |
| Edit Library .....                                       | 240 |
| Text editor.....   | 240 |
| Components of a library part.....                        | 242 |
| Body.....  | 242 |
| Pins .....   | 244 |
| Names.....   | 245 |
| Sheetpath designator.....                                | 245 |

---

|   |     |
|---|-----|
| Reference designator.....                   | 245 |
| Chapter 15: List Library.....               | 247 |
| Execution .....                             | 247 |
| Local Configuration .....                   | 248 |
| Chapter 16: Archive Parts in Schematic..... | 251 |
| Execution .....                             | 251 |
| Local Configuration .....                   | 252 |
| Configure LIBARCH.....                      | 253 |
| Configure COMPOSER.....                     | 256 |
| Chapter 17: Edit Library.....               | 259 |
| About Edit Library .....                    | 259 |
| Bitmaps and vectors .....                   | 260 |
| Editing a part with Edit Library.....       | 261 |
| Limit on a part's complexity.....           | 263 |
| Limit of total library size .....           | 264 |
| Execution .....                             | 264 |
| Local Configuration .....                   | 265 |
| Command reference.....                      | 268 |
| Selecting commands .....                    | 268 |
| AGAIN.....                                  | 269 |
| BODY.....                                   | 270 |
| BODY Kind of Part?.....                     | 271 |
| BODY Kind of Part? Block.....               | 272 |
| BODY Kind of Part? Graphic.....             | 272 |
| BODY Kind of Part? IEEE .....               | 272 |
| Place .....                                 | 273 |
| BODY command reference.....                 | 274 |
| BODY <Block> commands.....                  | 274 |
| BODY <Graphic> commands.....                | 275 |
| BODY <IEEE> commands.....                   | 282 |
| CONDITIONS.....                             | 287 |
| EXPORT .....                                | 289 |
| GET PART .....                              | 291 |
| IMPORT .....                                | 292 |

|                                      |     |
|--------------------------------------|-----|
| JUMP.....                            | 293 |
| JUMP A, B, C, D, E, F, G, H Tag..... | 293 |
| JUMP X-Location.....                 | 293 |
| JUMP Y-Location.....                 | 294 |
| LIBRARY.....                         | 294 |
| LIBRARY Update Current.....          | 295 |
| LIBRARY List Directory.....          | 296 |
| LIBRARY Browse.....                  | 297 |
| LIBRARY Delete Part.....             | 298 |
| LIBRARY Prefix.....                  | 299 |
| MACRO.....                           | 301 |
| NAME.....                            | 302 |
| NAME Add.....                        | 303 |
| NAME Delete.....                     | 303 |
| NAME Edit.....                       | 303 |
| NAME Prefix.....                     | 303 |
| ORIGIN.....                          | 304 |
| PIN.....                             | 305 |
| PIN Add.....                         | 305 |
| PIN Delete.....                      | 305 |
| PIN Name.....                        | 305 |
| PIN Pin-Number.....                  | 305 |
| PIN Type.....                        | 306 |
| PIN Shape.....                       | 307 |
| PIN Move.....                        | 307 |
| QUIT.....                            | 308 |
| QUIT Update File.....                | 308 |
| QUIT Write to File.....              | 309 |
| QUIT Initialize.....                 | 309 |
| QUIT.....                            | 309 |
| QUIT Abandon Edits.....              | 310 |
| REFERENCE.....                       | 311 |
| SET.....                             | 312 |
| SET Auto Pan.....                    | 312 |
| SET Backup File.....                 | 312 |
| SET Left Button.....                 | 312 |
| SET Error Bell.....                  | 313 |

---

|  |     |
|--|-----|
| SET Macro Prompts.....   | 313 |
| SET Power Pins Visible.....  | 313 |
| SET.....   | 313 |
| SET Visible Grid Dots.....   | 313 |
| TAG.....   | 314 |
| ZOOM.....  | 315 |
| ZOOM Center.....   | 315 |
| ZOOM In.....   | 315 |
| ZOOM Out.....  | 315 |
| ZOOM Select.....   | 315 |
| Chapter 18: Decompile Library.....                                 | 317 |
| Execution.....   | 317 |
| Local Configuration.....   | 318 |
| Chapter 19: Creating a library source file with a text editor..... | 321 |
| Library source file.....   | 321 |
| Block part definitions.....  | 321 |
| Graphic part definitions.....                                      | 321 |
| IEEE part definitions.....   | 322 |
| Prefix Definition.....   | 322 |
| Use of the prefix definition.....                                  | 322 |
| Constructing a prefix definition.....                              | 323 |
| Example 1.....   | 324 |
| Example 2.....   | 324 |
| Part definition.....   | 325 |
| Three types of part definitions.....                               | 325 |
| Components of a part definition.....                               | 325 |
| Defining a block symbol.....                                       | 328 |
| Part name string.....  | 329 |
| Sheetpath keyword.....   | 329 |
| Reference keyword.....   | 330 |
| Grid unit size and parts/package.....                              | 331 |
| Pin definitions.....   | 332 |
| Pin type.....  | 333 |
| Selectively displaying pins.....                                   | 334 |
| Pin-grid array.....  | 336 |



|  |     |
|--|-----|
| Defining a graphic symbol.....               | 339 |
| Defining a bitmap.....                       | 339 |
| Defining a vector.....                       | 340 |
| Graphic symbol considerations.....           | 341 |
| Converted form graphic symbol.....           | 342 |
| Defining an IEEE symbol.....                 | 346 |
| Part name string.....                        | 346 |
| Size and type definitions.....               | 347 |
| Pin definitions.....                         | 347 |
| Vector definitions.....                      | 347 |
| Chapter 20: Symbol Description Language..... | 351 |
| Syntax diagram.....                          | 351 |
| Identifiers.....                             | 352 |
| Tokens.....                                  | 352 |
| How syntax is described in this chapter..... | 355 |
| Prefix definition.....                       | 356 |
| Part definition.....                         | 358 |
| Pin definition.....                          | 362 |
| SHORT.....                                   | 364 |
| DOT.....                                     | 364 |
| CLK.....                                     | 365 |
| IN.....                                      | 365 |
| OUT.....                                     | 365 |
| I/O.....                                     | 365 |
| OC.....                                      | 365 |
| OE.....                                      | 365 |
| PWR.....                                     | 365 |
| PAS.....                                     | 365 |
| HIZ.....                                     | 365 |
| Bitmap definition.....                       | 368 |
| Vector definition.....                       | 371 |
| ARC.....                                     | 371 |
| CIRCLE.....                                  | 371 |
| LINE.....                                    | 371 |
| FILL.....                                    | 372 |
| TEXT.....                                    | 372 |

---

|  |     |
|--|-----|
| Converted form definition.....                       | 373 |
| Chapter 21: Compile Library.....                     | 375 |
| Execution .....                                      | 375 |
| Creating a custom library with Compile Library ..... | 375 |
| Running Compile Library.....                         | 376 |
| Local Configuration .....                            | 376 |
| Part V: Reporters.....                               | 379 |
| Chapter 22: Check Electrical Rules .....             | 381 |
| Execution .....                                      | 381 |
| Running Check Electrical Rules.....                  | 382 |
| Typical messages and resolutions.....                | 383 |
| How to specify conditions to check .....             | 383 |
| Example .....  | 385 |
| Local Configuration .....                            | 387 |
| Chapter 23: Cross Reference Parts.....               | 391 |
| Execution .....                                      | 391 |
| Local Configuration .....                            | 392 |
| Chapter 24: Convert Plot to IGES .....               | 397 |
| Execution .....                                      | 397 |
| Plot the file .....                                  | 397 |
| Running Convert Plot to IGES.....                    | 397 |
| Sample output .....                                  | 398 |
| Local Configuration .....                            | 399 |
| Chapter 25: Plot Schematic.....                      | 401 |
| Execution .....                                      | 401 |
| Be sure plotter is configured.....                   | 402 |
| Running Plot Schematic .....                         | 402 |
| Suppressing the title block, border, and text.....   | 402 |
| Sample output .....                                  | 403 |
| Local Configuration .....                            | 404 |
| Chapter 26: Print Schematic.....                     | 411 |
| Execution .....                                      | 411 |

|   |     |
|---|-----|
| Running Print Schematic.....                      | 412 |
| Sample output .....                               | 412 |
| Local Configuration .....                         | 413 |
| Chapter 27: Create Bill of Materials .....        | 417 |
| Execution .....                                   | 417 |
| Running Create Bill of Materials.....             | 417 |
| Sample output .....                               | 418 |
| Key fields .....                                  | 419 |
| Local Configuration .....                         | 420 |
| Chapter 28: Show Design Structure.....            | 425 |
| Execution .....                                   | 425 |
| Running Show Design Structure.....                | 425 |
| Sample output .....                               | 425 |
| Local Configuration .....                         | 426 |
| Part VI: Transfers.....                           | 429 |
| Chapter 29: To PLD.....                           | 431 |
| About To PLD .....                                | 431 |
| Execution .....                                   | 432 |
| Local Configuration of To PLD.....                | 433 |
| Local Configuration of FLDSTUFF.....              | 434 |
| Local Configuration of ANNOTATE .....             | 437 |
| Local Configuration of EXTRACT.....               | 440 |
| About EXTRACT.....                                | 442 |
| Key fields .....                                  | 442 |
| Unified documentation.....                        | 442 |
| Make a custom symbol .....                        | 442 |
| Defining the PLD's internal logic.....            | 443 |
| Select a device.....                              | 444 |
| Record part type and value on the schematic ..... | 444 |
| Chapter 30: To Digital Simulation.....            | 449 |
| About To Digital Simulation .....                 | 449 |
| Execution .....                                   | 450 |
| Local Configuration of To Digital Simulation..... | 451 |

---

|   |     |
|---|-----|
| Local Configuration of ANNOTATE .....   | 452 |
| Local Configuration of INET .....       | 455 |
| Local Configuration of IBUILD .....     | 459 |
| Local Configuration of ASCTOVST .....   | 460 |
| Chapter 31: To Layout .....             | 463 |
| About To Layout .....                   | 463 |
| Execution .....                         | 464 |
| Local Configuration of To Layout .....  | 464 |
| Local Configuration of FLDSTUFF .....   | 465 |
| Local Configuration of ANNOTATE .....   | 469 |
| Local Configuration of INET .....       | 472 |
| Local Configuration of ILINK .....      | 476 |
| Chapter 32: To Main .....               | 479 |
| About To Main .....                     | 479 |
| Appendix A: Command line controls ..... | 481 |
| ANNOTATE .....                          | 482 |
| BACKANNO .....                          | 483 |
| CLEANUP .....                           | 483 |
| COMPOSER .....                          | 484 |
| CROSSREF .....                          | 484 |
| DECOMP .....                            | 484 |
| DRAFT .....                             | 485 |
| ERC .....                               | 485 |
| EXTRACT .....                           | 485 |
| FLDATTRB .....                          | 486 |
| FLDSTUFF .....                          | 487 |
| HFORM .....                             | 488 |
| IFORM .....                             | 489 |
| ILINK .....                             | 490 |
| INET .....                              | 491 |
| LIBARCH .....                           | 492 |
| LIBEDIT .....                           | 493 |
| LIBLIST .....                           | 493 |
| PARTLIST .....                          | 494 |

|   |     |
|---|-----|
| PLOTALL .....   | 496 |
| PRINTALL .....  | 497 |
| SIMPLE .....  | 498 |
| TREELIST .....  | 498 |
| Appendix B: Netlist formats .....                       | 499 |
| Usage .....   | 499 |
| Creating your own netlist format .....                  | 500 |
| Flat netlists.....                                      | 500 |
| Example schematics.....                                 | 500 |
| Algorex (ALGOREX.CF) .....                              | 506 |
| Allegro (ALLEGRO.CF).....                               | 507 |
| AlteraADF (ALTERAAD.CF).....                            | 508 |
| AppliconBRAVO (APPLBRAV.CF) .....                       | 512 |
| AppliconLEAP (APPLLEAP.CF).....                         | 513 |
| Cadnetix (CADNETIX.CF) .....                            | 514 |
| Calay (CALAY.CF).....                                   | 515 |
| Case (CASE.CF) .....                                    | 516 |
| CBDS (CBDS.CF).....                                     | 518 |
| ComputerVision (COMPVISN.CF).....                       | 519 |
| EDIF (EDIF.CF).....                                     | 520 |
| EEDesigner (EEDESIGN.CF).....                           | 523 |
| FutureNet (FUTURE.CF) .....                             | 524 |
| HiLo (HILO.CF).....                                     | 530 |
| IntelADF (INTELADF.CF) .....                            | 532 |
| Intergraph (INTERGRA.CF).....                           | 536 |
| Mentor (MENTOR.CF).....                                 | 537 |
| MultiWire (MULTIWIR.CF).....                            | 538 |
| OrCAD/PCB II (PCBII.CF).....                            | 539 |
| OrCAD Programmable Logic Design Tools (PLDNET.CF).....  | 541 |
| OrCAD Digital Simulation Tools Model (VSTMODEL.CF)..... | 543 |
| PADS ASCII (PADSASC.CF) .....                           | 545 |
| PCAD (PCAD.CF) .....                                    | 547 |
| PCADnlt (PCADNLT.CF).....                               | 550 |
| RacalRedac (RACALRED.CF) .....                          | 551 |
| Scicards (SCICARDS.CF) .....                            | 553 |
| SPICE (SPICE.CF) .....                                  | 554 |

---

|  |     |
|--|-----|
| Tango (TANGO.CF).....                                | 558 |
| Telesis (TELESIS.CF).....                            | 561 |
| Vectron (VECTRON.CF).....                            | 562 |
| WireList.....  | 563 |
| Hierarchical netlists.....                           | 566 |
| Example Schematics.....                              | 566 |
| EDIF (EDIF.CH).....                                  | 571 |
| SPICE (SPICE.CH).....                                | 576 |
| Appendix C: Interpreting connectivity databases..... | 581 |
| Overview of connectivity databases.....              | 581 |
| About the incremental connectivity database.....     | 582 |
| About the linked connectivity database.....          | 583 |
| Typographical conventions.....                       | 583 |
| Terminology.....                                     | 583 |
| Token.....   | 584 |
| White space.....                                     | 584 |
| Quoted token.....                                    | 584 |
| String.....  | 584 |
| Delimiter.....                                       | 584 |
| Command.....   | 585 |
| Character.....                                       | 585 |
| Number.....  | 585 |
| Sub-part code.....                                   | 585 |
| Statement.....                                       | 586 |
| Parameter.....                                       | 586 |
| .INF format specification.....                       | 586 |
| Sample .INF file.....                                | 607 |
| Differences between .INF and .LNF files.....         | 610 |
| Appendix D: Creating a custom netlist format.....    | 611 |
| About netlist formats.....                           | 612 |
| Flat formats.....                                    | 612 |
| Hierarchical formats.....                            | 612 |
| Part and net orientations.....                       | 612 |
| OrCAD-supplied formats.....                          | 613 |
| Customer-contributed formats.....                    | 613 |

|  |     |
|--|-----|
| How to create a new format.....            | 613 |
| About format files .....                   | 614 |
| File names.....                            | 614 |
| Language .....                             | 614 |
| Functions.....                             | 615 |
| Standard symbols .....                     | 616 |
| User-defined symbols.....                  | 616 |
| Flat format.....                           | 617 |
| Hierarchical format.....                   | 620 |
| Required functions.....                    | 621 |
| Data functions .....                       | 622 |
| Traversal functions .....                  | 625 |
| Pipe file functions.....                   | 625 |
| General functions .....                    | 626 |
| C-language functions .....                 | 627 |
| Switches.....                              | 627 |
| Standard symbol reference.....             | 628 |
| Type definition reference.....             | 634 |
| Function reference .....                   | 637 |
| Error and warning messages .....           | 654 |
| Appendix E: Plotter information.....       | 657 |
| Plotter cable wiring.....                  | 658 |
| Plotter problems .....                     | 660 |
| Plotting to a printer.....                 | 662 |
| General plotter tips.....                  | 663 |
| HP plotters.....                           | 664 |
| HI plotters .....                          | 665 |
| Calcomp plotters .....                     | 665 |
| Notes on plotter and printer drivers ..... | 669 |
| Glossary .....                             | 673 |
| Index .....                                | 679 |

OrCAD's **Schematic Design Tools** operates within the **OrCAD/ESP Design Environment**. This environment provides many features that make it easier to access and use OrCAD's electronic design automation (EDA) tool sets.

This book is a reference guide to **Schematic Design Tools**, the tool set used to create schematic designs. For detailed information about the design environment, see the *OrCAD/ESP Design Environment User's Guide*.

---

## Tools and tool sets

A *tool set* is a collection of tools designed to perform a set of electronic design automation tasks. There are currently four OrCAD tool sets. They are:

- ❖ **Schematic Design Tools**
- ❖ **Programmable Logic Design Tools**
- ❖ **Digital Simulation Tools**
- ❖ **Printed Circuit (PC) Board Layout Tools**

The tool sets allow you to access the same design in different ways.

Buttons for the OrCAD design tool sets appear on the main design environment screen, even if you have only one tool set installed on your system.

To select the **Schematic Design Tools** tool set from the main design environment screen, point to the **Schematic Design Tools** button and double-click. In a moment, you will see the screen for **Schematic Design Tools** as shown in the figure on the next page.



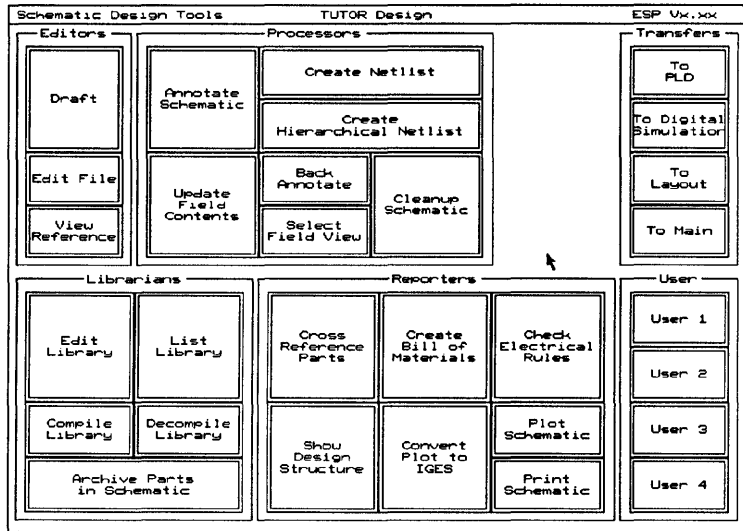

Schematic Design Tools screen.

In tool sets, tools are grouped according to function. The six categories are:

- ❖ Editors
- ❖ Processors
- ❖ Librarians
- ❖ Reporters
- ❖ Transfers
- ❖ User buttons

These functions are described below.

**Editors** Editors modify or create some part of the design database. An example of an editor is the schematic editor, **Draft**. Another editor is **Edit File**, which uses a text editor to view reports and enter text.

**Processors** Processors read, modify, then rewrite the design database. For example, **Annotate Schematic** is a processor. Processors generally do not create human-readable reports, but rather create or modify database information. Processors may create data that will be used by tools outside the ESP design environment.

**Librarians** Librarians are tools for managing and creating library objects that can be used by all designs, not just the current design. **Edit Library** is an example of a librarian. It is used to create a new schematic symbol for a component. This component should be available in all future design work, so it is stored in the library database.

**Reporters** Reporters create human-readable reports, but do not modify design data in any way. For example, a reporter creates the Bill of Materials report, a list of all the components used in the design. The tools for printing and plotting are also reporters. Reporters may create reports that will be used by tools outside the ESP design environment.

**Transfers** Transfer tools manage the steps needed to move design information from one tool set to another. Transfers have two parts. The first updates the database used by the current tool set so that it is current and up-to-date in every respect. The second part changes to the new tool set used to view the design. The transfer tools take care of intermediate steps so that you don't have to.

For example, the **To Digital Simulation** transfer tool performs these steps:

- ❖ Annotates the reference designators in the design
- ❖ Builds the connectivity database
- ❖ Builds the link between the schematic and the simulator, so that simulation directives inserted in the schematic can be accessed by the simulator
- ❖ Transfers control to **Digital Simulation Tools**

### User buttons

A user button is the most basic way in which the ESP environment can be extended to fit your particular requirements and make your work easier and more convenient.

A user button can be set up to run any system command. You can set up a user button to run a spreadsheet program, which you can use to analyze design information. Or, you can program user buttons to run utility programs, communications programs, other graphical user interfaces and their programs—almost any program you like. You can also write batch files and program user buttons to run them.

ESP places four user buttons inside every tool set. Chapter 4 of the *OrCAD/ESP Design Environment User's Guide* explains how to define a user button.

---

### Mouse techniques



You can do all your work in Schematic Design Tools (except typing text and numbers) using the mouse.

You *point* to an object by moving the pointer until the tip of the arrow touches the object. Do this by moving the mouse.

You *click* by pointing to an object and then pressing and releasing the left mouse button once. When you click on a button, it becomes *highlighted* and a menu pops up in the upper left corner of the screen.

In this guide, the words “click,” “highlight,” and “select” all mean the same thing. In every case the action you take is the same: position the pointer, press the left mouse button, and quickly release it.

You *double-click* by first pointing to an object and then clicking the left mouse button twice. Don't move the mouse while you double-click.

### Left and right mouse buttons

- ❖ Clicking the left mouse button is the same as pressing the <Enter> key. In this guide, when you are instructed to “press <Enter>,” you can use either the keyboard or the mouse, whichever you prefer.
- ❖ Clicking the right mouse button is the same as pressing the <Esc> key. In this guide, when you are instructed to “press <Esc>,” you can use either the keyboard or the mouse, whichever you prefer.

---

## Keyboard equivalents



Many of the explanations and instructions in this book use the mouse terminology explained on the previous page. If you prefer to use the keyboard, however, there are keyboard equivalents to nearly every mouse operation. Instead of moving the mouse to move the pointer from button to button, you can:

- ❖ Press <Tab> to move from one tool category to the next.
- ❖ Press <Space bar> to move from button to button within a category.
- ❖ Press <Shift><Tab> to move the pointer backwards to the next category.
- ❖ Press <Enter> to select the button the pointer rests on.

## “Enter” and “Type”

The instructions in this guide use the terms “enter” and “type” to mean two different things. When the instructions tell you to enter something, you press the appropriate keys and end by pressing <Enter>. When the instructions tell you to type something, you press the appropriate keys, but do *not* press <Enter>.

---

## About this guide

This guide is organized according to function. The basic parts of this guide are:

- ❖ Part I: Configuration
- ❖ Part II: Editors
- ❖ Part III: Processors
- ❖ Part IV: Librarians
- ❖ Part V: Reporters
- ❖ Part VI: Transfers

Each tool is described in a chapter in the appropriate part of this guide. For example, to find information about **Draft**, look in *Part II: Editors*.

**Conventions** The notation conventions used in this guide are as follows:

**BOLD CAPS** Used for main menu commands.

**Bold** Used for other commands.

**Courier bold** Used for text you enter.

*Italics* Used for references to other sections, chapters, parts of this guide, or other guides.

<B> Brackets <> show a key (or keys) that you press. Here are some examples of how the brackets are used.

*As shown*      *Means*

<Esc>      Press the escape key.

<Ctrl><S>      Press the control key, and while still holding it down, press the "S" key.

<Esc> <G>      Press the escape key and let it go. Then press the "G" key.

"Prompt"      Quotation marks show program prompts.

Boxes      The shadow box shown below shows a program or system prompt. Any bold type following the prompt shows text that you enter. For example:

|                |
|----------------|
| Abandon edits? |
|----------------|

This kind of shadow box shows a program menu.

|             |
|-------------|
| Hardcopy    |
| Destination |
| File        |

△ **NOTE:** Notes contain important reminders or hints.

▲ **CAUTION:** Cautions contain information about preventing damage to equipment, software, or data.

# P A R T I : C O N F I G U R A T I O N

When you install **Schematic Design Tools** on your system's hard disk, it is configured and ready to run.

Part I explains how to customize **Schematic Design Tools** configuration.

*Chapter 1: Configure Schematic Tools* describes how to modify:

- ❖ Driver Options
- ❖ Printer and Plotter Output Options
- ❖ Library Options
- ❖ Worksheet Options
- ❖ Macro options for both **Draft and Edit Library**
- ❖ Hierarchy Options
- ❖ Color and Pen Plotter Table
- ❖ Template Table
- ❖ Key Fields
- ❖ Matrix for **Check Electrical Rules**





## *Configure Schematic Tools*

OrCAD's ESP environment has three types of configuration, all of which customize and save information used to run OrCAD tools and tool sets.

- ❖ *ESP configuration* defines driver options, the text editor, startup design, and monitor display colors. Although ESP is already configured when installed, you can change the configuration whenever you want to change ESP parameters.

The *OrCAD/ESP Design Environment User's Guide* provides detailed instructions for customizing the design environment.

- ❖ *Tool set configuration* defines driver, library, work area, and macro options, plus tool set-specific monitor display colors and display drivers. Tool set configuration applies to all tools in a tool set and can be accessed from every button in the tool set except Transfers and User buttons. It has a default configuration when installed but can also be configured anytime you want to change the tool set parameters.

The remainder of this chapter provides detailed instructions for customizing the Schematic Design Tools configuration.



- ❖ *Local configuration* determines input and output files plus special processing options for a particular tool. If a tool runs several processes, each process can be locally configured.

Local configuration is set up when the design is created, with input and output filenames defaulting to the design name in most cases. You usually configure a tool when you begin work on a design, or anytime you want to change the tool's parameters.

The chapter that describes a tool also provides instructions for customizing its local configuration.

## Display the Configure Schematic Design Tools screen

With the Schematic Design Tools screen displayed, select any of the Editors, Processors, Librarians, or Reporters buttons. For example, select **Draft**.

The menu shown at right displays at the top of the screen. Select **Configure Schematic Tools**.

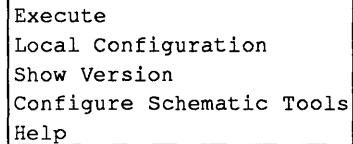

```
Execute
Local Configuration
Show Version
Configure Schematic Tools
Help
```

The Configure Schematic Design Tools screen is too large to show in one illustration. Each area on the Configure Schematic Design Tools screen is shown in the sections that follow.

Move the pointer down until it touches the lower edge of the display, and the display pans down to show more options. When you get to the bottom, the display only pans up.

If you prefer to use keyboard commands, press <Page Down> to move the window down part of a screen at a time, and <Page Up> to go up again. Press <End> to go to the bottom of the configuration screen, and <Home> to return to the top again.

In various places within the configuration screen, there are boxes or windows in which lists (usually of files) display.

Using the arrow buttons to the right of each list box, these lists can be moved up and down in a manner similar to the scrolling process used for the configuration screen.

When you finish making changes, select **OK** to save your changes and return to the Schematic Design Tools screen.

If you do not want to save your changes, select **Cancel** to return to the Schematic Design Tools screen.

## Driver Options

The Driver Options (figure 1-1) area defines the driver prefix, display driver, printer driver, and plotter driver. These are described on the following pages.

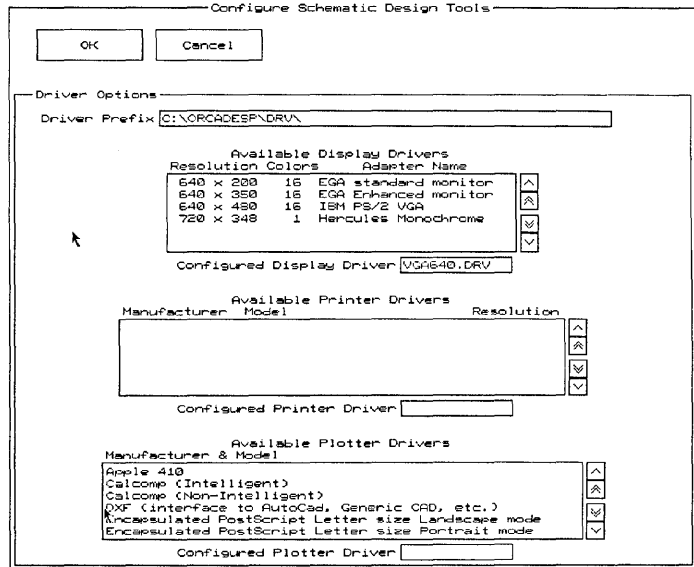

Figure 1-1. Driver Options area of Configure Schematic Design Tools screen.

**Driver Prefix** The **Driver Prefix** is the directory path or disk drive where **Schematic Design Tools** finds and loads the display, printer, and plotter drivers.

The driver prefix is set during the installation process and does not need to change unless you move drivers to a different directory or create custom drivers in another directory.

To define the driver prefix, place the cursor in the **Driver Prefix** entry box and enter the pathname of the directory containing your device drivers.

△ ***NOTE:** Only the drivers that are recognized by name appear in the list box. Custom drivers do not appear and need to be typed into the entry box.*

Once you enter a driver prefix, all of the drivers in that directory display in the appropriate list box: **Available Display Drivers**, **Available Printer Drivers**, or **Available Plotter Drivers**. Each of these list boxes is described in the sections that follow.

*Example* The **Driver Prefix** is created during the installation process. If you installed **Schematic Design Tools** on your C: drive, the prefix is:

Driver Prefix

This tells **Schematic Design Tools** to look for the drivers in the **ORCADESP\DRV** directory on the C: drive.

**Available Display Drivers**

The Available Display Drivers area of the screen is where you choose which graphics display driver to load.

A list box (figure 1-2) lists the different display drivers that are available in the directory path specified in the Driver Prefix entry box.

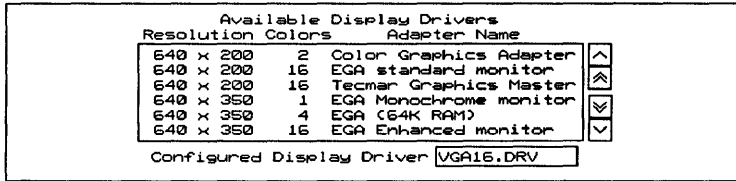

Figure 1-2. Available Display Drivers list box.

Select the driver that is appropriate for your system by clicking on it. To see other drivers not displayed in the list box, use the scroll buttons at the right of the list box to scroll the list of drivers up and down.

Once you select the desired display driver, its filename displays in the Configured Display Driver entry box.

You do not have to select a display driver from the Available Display Drivers list box. Instead, simply click in the Configured Display Driver entry box and enter the driver name. However, be sure that the driver is in the directory displayed in the Driver Prefix entry box.

△ **NOTE:** Only the drivers that are recognized by list name appear in the list box. Custom drivers do not appear, and need to be typed into the entry box.

*Example* If you select the EGA Enhanced monitor from the drivers displayed in figure 1-2, the following displays:

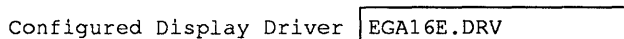

△ **NOTE:** If a driver is not configured here, Schematic Design Tools uses the one selected during installation.

**Available Printer Drivers**

The **Available Printer Drivers** area of the screen is where you choose which printer driver to load.

A list box (figure 1-3) lists the printer drivers available in the directory path specified in the **Driver Prefix** entry box.

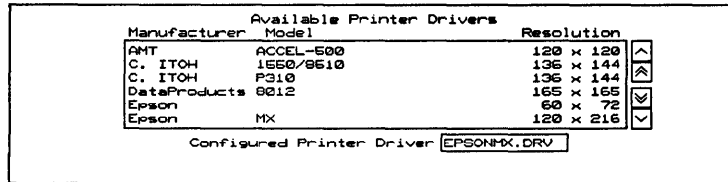

Figure 1-3. Available Printer Drivers list box.

Select the driver for your printer by clicking on it. If you need to see other drivers not displayed in the window, use the scroll buttons at the right of the list box to scroll the list of drivers up and down.

Once you select the desired printer driver, its filename displays in the **Configured Printer Driver** entry box.

You do not have to select a printer driver from the **Available Printer Drivers** list box. Instead, simply click in the **Configured Printer Driver** entry box and enter the driver name. However, be sure that the driver is in the directory displayed in the **Driver Prefix** entry box.

△ **NOTE:** Only the drivers that are recognized by list name appear in the list box. Custom drivers do not appear, and need to be typed into the entry box.

**Example** If you select the Epson printer from the drivers displayed in figure 1-3, the following displays:

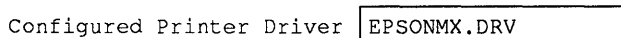

### Available Plotter Drivers

The **Available Plotter Drivers** area of the screen is where you choose which plotter driver to load.

A list box (figure 1-4) lists the different plotter drivers that are available in the directory path specified in the **Driver Prefix** entry box.

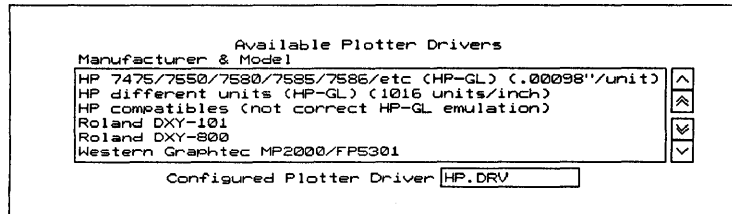

Figure 1-4. Available Plotter Drivers list box.

Select the driver for your plotter by clicking on it. If you need to see other drivers not displayed in the list box, use the scroll buttons at the right of the list box to scroll the list of drivers up and down.

Once you select the desired plotter driver, its filename displays in the **Configured Plotter Driver** entry box.

You do not have to select a plotter driver from the **Available Plotter Drivers** list box. Instead you can enter the name of a driver in the **Configured Plotter Driver** entry box by simply typing it and pressing <Enter>.

△ **NOTE:** Only the drivers that are recognized by list name appear in the list box. Custom drivers do not appear and need to be typed into the entry box.

### Example

If you select the first HP driver from the drivers displayed in figure 1-4, the following displays:

Configured Plotter Driver

For additional information about **Schematic Design Tool's** plotting capabilities and how to plot a file, see *Chapter 25: Plot Schematic*.

## Printer/Plotter Output Options

The **Printer/Plotter Output Options** area (figure 1-5) defines the ports to which your printer and plotter are connected. If you choose a serial port (COM1:, COM2:, COM3:, or COM4:), you define its baud rate, parity, number of stop bits, and number of data bits.

Select the desired output port for your printer or plotter or both.

If you select a parallel port (LPT1:, LPT2:, or LPT3:), the baud rate, parity, data bits, and stop bits options are dimmed. You do not need to define these communications parameters for parallel ports.

If you select a serial port (COM1:, COM2:, COM3:, or COM4:), the baud rate, parity, data bits, and stop bits options become available. Click on the desired settings for your printer or plotter or both. These settings are determined by the needs of your printer or plotter and the serial port to which it is connected. If necessary, see your printer or plotter documentation.

△ *NOTE: The BIOS on some computers does not support COM3: and COM4:. If your computer's BIOS does not support COM3: and COM4:, you cannot use these ports.*

Unavailable options  
On monochrome screens and in OrCAD manuals, options that are not available are shown with a line through them. On color monitors, the options are dimmed.

| Printer/Plotter Output Options |  |                             |  |
|--------------------------------|--|-----------------------------|--|
| Printer Port                   | <input checked="" type="radio"/> LPT1: | <input type="radio"/> LPT2: | <input type="radio"/> LPT3:                  |
|                                | <input type="radio"/> COM1:            | <input type="radio"/> COM2: | <input type="radio"/> COM3:                  |
|                                | <input type="radio"/> COM4:            |                             |  |
| Baud Rate                      | <input type="radio"/> 300              | <input type="radio"/> 4800  | <input type="radio"/> Even Parity            |
|                                | <input type="radio"/> 1200             | <input type="radio"/> 9600  | <input type="radio"/> Odd Parity             |
|                                | <input type="radio"/> 2400             | <input type="radio"/> 19200 | <input type="radio"/> No Parity              |
|                                |  |                             | <input type="radio"/> 8 Data Bits            |
|                                |  |                             | <input type="radio"/> 7 Data Bits            |
|                                |  |                             | <input type="radio"/> 1 Stop Bit             |
|                                |  |                             | <input type="radio"/> 2 Stop Bits            |
| Plotter Port                   | <input type="radio"/> LPT1:            | <input type="radio"/> LPT2: | <input type="radio"/> LPT3:                  |
|                                | <input checked="" type="radio"/> COM1: | <input type="radio"/> COM2: | <input type="radio"/> COM3:                  |
|                                | <input type="radio"/> COM4:            |                             |  |
| Baud Rate                      | <input type="radio"/> 300              | <input type="radio"/> 4800  | <input checked="" type="radio"/> Even Parity |
|                                | <input type="radio"/> 1200             | <input type="radio"/> 9600  | <input type="radio"/> Odd Parity             |
|                                | <input type="radio"/> 2400             | <input type="radio"/> 19200 | <input type="radio"/> No Parity              |
|                                |  |                             | <input checked="" type="radio"/> 8 Data Bits |
|                                |  |                             | <input type="radio"/> 7 Data Bits            |
|                                |  |                             | <input checked="" type="radio"/> 1 Stop Bit  |
|                                |  |                             | <input type="radio"/> 2 Stop Bits            |

Figure 1-5. Printer/Plotter Output Options area of Configure Schematic Design Tools screen.



## Library Options

The **Library Options** area (figure 1-6) defines the prefix **Schematic Design Tools** uses to find libraries, and the libraries that load when the tools run. It also specifies whether the name table resides in main memory, EMS memory, or on disk (see *Name Table Location and Symbolic Data Location* in this chapter); and whether the symbolic data resides in EMS memory or on disk. The active library size is also defined here.

**Draft** and other schematic design tools load the libraries listed in the **Configured Libraries** list box when they run. The number of libraries loaded affects the total amount of system memory available for worksheet design. It is possible to configure **Schematic Design Tools** to load more libraries than can be placed in 640K system RAM. Usually, four to eight libraries are sufficient and leave enough memory for designs.

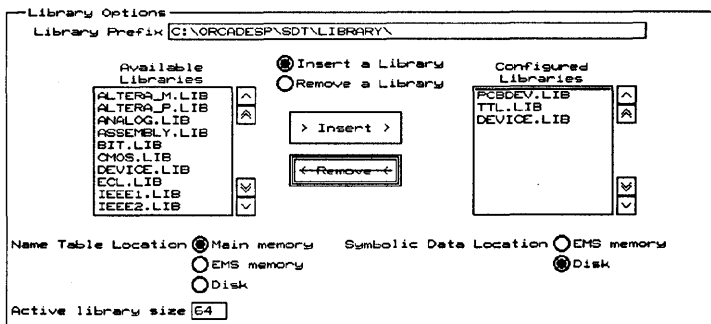

Figure 1-6. *Library Options* area of *Configure Schematic Design Tools* screen.

**Draft** loads and maintains libraries in the order in which they are listed in the **Configured Libraries** list box. This is important when retrieving parts while creating schematics. When you ask **Draft** to get a certain part name, it searches the libraries in the order they are listed in the **Configured Libraries** window and gets the first part it finds with a matching name.

Duplicate part names can cause problems when you get parts in **Draft**. Note that OrCAD-supplied parts libraries do not have parts with duplicate names in the *same* library; however, some libraries, such as the PSPICE.LIB and SPICE.LIB libraries, do contain parts that have the same names as parts in the other library. In these cases, the order in which libraries load can be very important.

If you create your own version of an OrCAD-supplied part, save it in a custom library you create yourself. Then, configure **Schematic Design Tools** to load this library before any OrCAD libraries by placing it first in the **Configured Libraries** window. Using custom libraries also makes sure your custom parts are not overwritten if the original library is updated by OrCAD.

To create a custom library, use **Edit Library's QUIT Write to File** command (described in *Chapter 2: Draft*). For instructions on how to change the order of the configured libraries list, see *Changing the library order* in this chapter.

### Library Prefix

The **Library Prefix** is the disk drive or directory path where **Schematic Design Tools** finds and loads libraries.

To define the library prefix, place the cursor in the **Library Prefix** entry box and enter the pathname of the directory containing your libraries. Once you enter a library prefix, all of the libraries in that directory display in the **Available Libraries** list box.

### Example

The example below tells **Schematic Design Tools** to look for libraries in the ORCADESP\SDT\LIBRARY subdirectory on the C: hard disk.

Library Prefix

### **Inserting a library**

Before inserting a library in the **Configured Libraries** window, be sure that the **Insert a Library** option is selected. When it is, the **Available Libraries** window displays all of the libraries available in the directory specified in the **Library Prefix** entry box. In addition, the **Insert** option becomes highlighted and available for use.

Select the library that you would like to add to the **Configured Libraries** list by clicking on it. If you need to see other libraries that aren't displayed in the window, use the arrow keys at the right of the window to scroll the list of libraries up and down.

The **Configured Libraries** window contains a bar. On color monitors, this bar is green. It shows the position in which the next library will be inserted. To move this bar, point the cursor where you want it to appear and click the left mouse button.

Click the **Insert** button. The selected library is added to the **Configured Libraries** list, above the green line.

For information about the order of libraries, see *Library Options*. For information about changing the order of libraries, see *Changing the library order*.

### **Removing a library**

Before removing a library from the **Configured Libraries** window, be sure that the **Remove a Library** option is selected. When it is, the **Available Libraries** window is dimmed. In addition, the **Remove** button becomes active and available for use.

Select the library that you would like to remove from the **Configured Libraries** list by clicking on its name. If you need to see other libraries that aren't displayed in the window, use the arrow keys at the right of the window to scroll the list of libraries up and down.

Once you select a library, click the **Remove** button. ESP removed the selected library from the **Configured Libraries** list.

**Changing the library order**

Draft loads and maintains libraries in the order in which they are listed in the **Configured Libraries** window. This is important when retrieving parts while creating schematics. When you tell **Draft** to get a certain part name, it searches the libraries in the order they are listed in the **Configured Libraries** window and gets the first part it finds with a matching name. If you want to change the order in which your libraries are listed, follow these steps:

- ❖ Libraries must be reordered one at a time. Determine which library you want to move and remove it from the **Configured Libraries** window.
- ❖ Select the **Insert a Library** option. Move the green bar in the **Configured Libraries** list until it is positioned where you want to insert the library.
- ❖ Insert the library that you removed earlier. It appears in the **Configured Libraries** window just above the green line.

**Types of libraries**

**Schematic Design Tools** uses two types of libraries: the active library and the on-line library. Both of these libraries contain a name table and a symbolic data table.

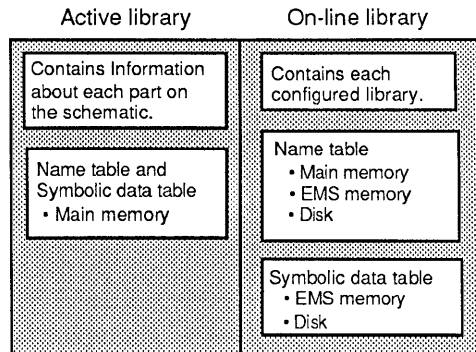

*Active library*      The active library contains information about each part on the schematic. It always resides in main memory and can be configured to be 64–152K.

- ❖ The name table contains a list of the parts found on the schematic.
- ❖ The symbolic data table contains all of the symbol information for each part on the schematic.

This library is built by copying information from the other libraries as a schematic is loaded or when you get a new part using **Draft's GET** command, and is discarded when you exit **Draft**. Because all of the needed information is in one library, redraws and panning are very fast.

*On-line library*      The on-line library contains information about each configured library. These are the libraries listed in the **Configured Libraries** list box.

- ❖ The name table contains a list of all the parts in each configured library. It can be stored in main memory, EMS memory, or on disk. If you place the name table in EMS, the effective increase in capacity is limited only by how much EMS memory is in your computer. EMS allows for 32 MB of memory. This will handle the 20,000 parts included with **Schematic Design Tools** many times over.
- ❖ The symbolic data table contains all of the symbol information for each part in each configured library. It can be stored in EMS memory or on disk. If you place the symbolic data table in EMS, **Draft's GET** and **LIBRARY Browse** commands run more quickly.

If you don't have EMS memory, you can configure the software to keep the symbolic data table on disk. Depending on the speed of your disk, **Draft's GET** and **LIBRARY Browse** commands will slow down a little or a lot, but **Draft** will redraw the screen as fast as always, because the information it uses for redraws is in the active library.

Depending on the performance of your disk drive and your EMS implementation, you can expect the performance impacts shown in Table 1-1.

|  | <i>Main<br/>Memory</i> | <i>EMS<br/>Memory</i> | <i>Disk</i> | <i>Comments</i>  |
|--|------------------------|-----------------------|-------------|--|
| <i>Name Table Location<br/>Symbol Table Location</i> | √                      | √                     |             | This is usually the most efficient configuration.  |
| <i>Name Table Location<br/>Symbol Table Location</i> |                        | √<br>√                |             | This is slightly slower than the configuration described above. You can add additional EMS memory to get more parts on line.   |
| <i>Name Table Location<br/>Symbol Table Location</i> | √                      |                       | √           | This is slower yet, but is still tolerable.  |
| <i>Name Table Location<br/>Symbol Table Location</i> |                        | √                     | √           | This configuration is very slow, and should only be used for three special cases: <ul style="list-style-type: none"> <li>• Very large worksheets. For example, E-size drawings with many parts.</li> <li>• Systems with a small amount of EMS memory.</li> <li>• Systems with a small apparent main memory. This can be caused by running multi-tasking software or a large network driver.</li> </ul> |
| <i>Name Table Location<br/>Symbol Table Location</i> |                        |                       | √<br>√      | This is a severe compromise to Draft's speed. It should only be used with portable computers that come with 512K memory. If your hard disk drive is fast, this configuration may be more tolerable.  |

Table 1-1. EMS implementation performance impacts.

**Active library size**

Each time you load a worksheet, **Draft** creates a temporary active library file. When you exit **Draft**, it discards the temporary file.

The active library contains definitions of each part on the worksheet. EMS is reserved for libraries only. By using EMS for libraries, you can have much larger designs and take full advantage of OrCAD's extensive libraries.

The size of the active library can be between 64–152K. If your worksheet contains few parts, set the active library size to 64K. For example, if your design is a memory board with many 41256 chips or a few types of glue logic chips, the active library can be quite small. If your worksheet contains many different parts, you will have to increase the size of the active library.

Use the **CONDITIONS** command in **Draft** to determine whether or not you need to increase or decrease the size of the active library.

## Worksheet Options

The **Worksheet Options** area (figure 1-7) defines the worksheet prefix, the default worksheet file extension, and default title block information.

Worksheet Options

ANSI title block

ANSI grid references

Use alternate worksheet prefix

Worksheet Prefix:

Default worksheet file extension:

Sheet size:

Document number:

Revision:

Title:

Organization name:

Organization address:

Figure 1-7. *Worksheet Options* area of *Configure Schematic Design Tools* screen.

Select any combination of the following options:

- ANSI title block

Causes **Schematic Design Tools** to use ANSI Standard Y14.1-1980 title block on worksheets, instead of the default.

The default title block is shown below.

|                         |                 |              |
|-------------------------|-----------------|--------------|
| OrCAD                   |                 |              |
| 3175 N.W. Alcock Drive  |                 |              |
| Hillsboro, Oregon 97124 |                 |              |
| (503) 690-9881          |                 |              |
| Title                   |                 |              |
| Demonstration Worksheet |                 |              |
| Size                    | Document Number | REV          |
| A                       | 191-0005        | A            |
| Date:                   | May 24, 1991    | Sheet 1 of 1 |

Figure 1-8. *Sample OrCAD title block.*



The alternative, an ANSI Standard title block, is shown below:

|              |  |         |                    |
|--------------|--|---------|--------------------|
|              | OrCAD<br>3175 N.W. Alcock Drive<br>Hillsboro, Oregon 97124<br>(503) 690-9881 |         |                    |
|              | Demonstration Worksheet  |         |                    |
|              | SIZE<br>A  | FSCM NO | DWG NO<br>191-0005 |
| May 24, 1991 | SCALE  |         | REV<br>A           |
|              |  | SHEET   | 1 OF 1             |

Figure 1-9. ANSI title block for sheet sizes A through C.

**Draft** has five worksheet sizes built in: A through E (American) or A4 through A0 (International Standards Organization). Using the **Template Table**, you can tailor the dimensions and many characteristics of each to match your requirements.

The ANSI title blocks for sheet sizes A, B, and C are different from ANSI title blocks for sheet sizes D and E. See the ANSI Y14.1-1980 specification for more information.

ANSI title blocks are larger than the default OrCAD title blocks. On an A-size drawing, they take up a large amount of the drawing area.

Tables 1-2 and 1-3 on the next page list the sizes of ANSI (A-E) and ISO (A4-A0) sheet sizes and drawing areas within the specified borders. Unfortunately, most, if not all, PC-compatible printers and plotters are unable to print as close to the edge of the page as specified in the ANSI and ISO standards.

Tables 1-4 and 1-5 list the reduced dimensions that will work with most printers and plotters. It is possible that your printer or plotter can print closer to the edge of the paper than allowed by these values. Hence, you may wish to adjust the sizes in the **Template Table** area of the **Configure Schematic Design Tools** screen (described later in this chapter).

| Sheet Size | Outside Border |          | Inside Border |          |
|------------|----------------|----------|---------------|----------|
|            | Horizontal     | Vertical | Horizontal    | Vertical |
| A          | 11.0           | 8.5      | 10.5          | 7.7      |
| B          | 17.0           | 11.0     | 15.7          | 10.2     |
| C          | 22.0           | 17.0     | 21.0          | 15.5     |
| D          | 34.0           | 22.0     | 32.0          | 21.0     |
| E          | 44.0           | 34.0     | 43.0          | 32.0     |

Table 1-2. ANSI horizontal and vertical dimensions of worksheets in inches.

| Sheet Size | Outside Border |          | Inside Border |          |
|------------|----------------|----------|---------------|----------|
|            | Horizontal     | Vertical | Horizontal    | Vertical |
| A4         | 297            | 210      | 276.8         | 187.9    |
| A3         | 420            | 297      | 388.6         | 266.7    |
| A2         | 594            | 420      | 563.8         | 388.6    |
| A1         | 841            | 594      | 800.1         | 553.7    |
| A0         | 1189           | 841      | 1137.9        | 789.9    |

Table 1-3. ISO horizontal and vertical dimensions of worksheets in millimeters.

| Sheet Size | Outside Border |          | Inside Border |          |
|------------|----------------|----------|---------------|----------|
|            | Horizontal     | Vertical | Horizontal    | Vertical |
| A          | 9.7            | 7.2      | 9.5           | 7.0      |
| B          | 15.2           | 9.7      | 15.0          | 9.5      |
| C          | 20.2           | 15.2     | 20.0          | 15.0     |
| D          | 32.2           | 20.2     | 32.0          | 20.0     |
| E          | 42.2           | 32.2     | 42.0          | 32.0     |

Table 1-4. OrCAD default horizontal and vertical dimensions of worksheets in inches.

| Sheet Size | Outside Border |          | Inside Border |          |
|------------|----------------|----------|---------------|----------|
|            | Horizontal     | Vertical | Horizontal    | Vertical |
| A          | 246.4          | 182.9    | 241.3         | 177.8    |
| B          | 386.1          | 246.4    | 381           | 241.3    |
| C          | 513.1          | 386.1    | 508           | 381      |
| D          | 817.9          | 513.1    | 812.8         | 508      |
| E          | 1071.9         | 817.9    | 1066.8        | 812.8    |

Table 1-5. OrCAD horizontal and vertical dimensions of worksheets in millimeters.

ANSI grid references

Causes Schematic Design Tools to use ANSI Standard Y14.1-1980 grid references on worksheets. Table 1-6 shows both ANSI and Common grid references.

| Sheet Size | Ansi Reference |              | Common References |              |
|------------|----------------|--------------|-------------------|--------------|
|            | X Grid Range   | Y Grid Range | Y Grid Range      | X Grid Range |
| A          | N/A            | N/A          | A..D              | 1..8         |
| B          | N/A            | N/A          | A..D              | 1..8         |
| C          | A..D           | 1..4         | A..D              | 1..8         |
| D          | A..D           | 1..8         | A..D              | 1..8         |
| E          | A..H           | 1..8         | A..D              | 1..8         |

Table 1-6. X and Y grid references. N/A indicates that the value is not applicable because the sheet size does not have grid references per ANSI Y14.1-1980.

❑ Use alternate worksheet prefix

Do not select this option if you are using ESP. ESP manages all paths and prefixes for you. This option is provided for compatibility with older versions of OrCAD software. When you select this option, the **Worksheet Prefix** entry box becomes available:

Worksheet Prefix

The **Worksheet Prefix** is the disk drive and directory path where **Draft** finds worksheet files containing your schematic designs.

If you make an entry that falls into any of the categories listed below, **Draft** looks for the worksheet in the location specified in the **Worksheet** entry box:

- ❖ Drive name. For example, A:, B:, C:, or D:.
- ❖ Drive name followed by a backslash (\). For example, A:\, B:\, C:\, or D:\.
- ❖ A backslash (\).
- ❖ A pathname that begins with any of the categories listed above.

If you add a directory path that doesn't begin like one of the examples outlined above, **Draft** treats the directory path as a sub-directory in the current design.

### *Examples*

Use this prefix to find files on the A: floppy disk:

Worksheet Prefix

Use this prefix to find files in the \ORCAD\DESIGN5 subdirectory on the C: hard disk:

Worksheet Prefix

Use this prefix to find files in the subdirectory called SHEET in the current design directory:

Worksheet Prefix

|   |  |
|---|--|
| <b>Default worksheet file extension</b> | <p>If you enter a filename that doesn't end with a filename extension or a period in response to one of <b>Draft's</b> prompts, <b>Draft</b> appends the extension specified here to the name. For example, if you enter "SHEET" while in <b>Draft</b>, <b>Draft</b> appends the extension specified here.</p> <p>If you enter a filename that ends with an extension or ends with a period (.), this field is ignored. For example, if you enter "SHEET." or "SHEET.EXT" while in <b>Draft</b>, <b>Draft</b> does not append the extension specified here.</p> <p>△ <i>NOTE: The information entered in the remaining fields is used as the default information on a schematic worksheet. For this information to appear on a worksheet, it must be entered before the worksheet is created.</i></p> <p><i>Once a worksheet is created, any changes made here are not reflected on an existing worksheet. To change sheet size, use <b>Draft's</b> SET command. To change the worksheet's title block information, use <b>Draft's</b> EDIT command.</i></p> |
| <b>Sheet size</b>                       | <p>This field must be set to A, B, C, D, or E (American), or to A4, A3, A2, A1, or A0 (International Standards Organization). American dimensions are inches, and International Standards Organization dimensions are millimeters. You specify whether American or European dimensions are used on the <b>Template Table</b>.</p>  |
| <b>Document number</b>                  | <p>The document number may contain up to 36 characters.</p>  |
| <b>Revision</b>                         | <p>The revision code may contain up to three characters.</p>   |
| <b>Title</b>                            | <p>The title may contain up to 44 characters.</p>  |
| <b>Organization name</b>                | <p>The organization name may contain up to 44 characters.</p>  |
| <b>Organization address</b>             | <p>Each organization address line may contain up to 44 characters.</p>   |

## Macro Options

A macro is a series of commands that executes automatically at the touch of a single key or key combination. Using **Schematic Design Tools**, you can construct macros and store them in a file for later use with **Draft** or **Edit Library**.

**Macro Options** (figure 1-10) defines the macro buffer size, the macro file (a file that can contain many macros), and the name of an initial macro (a macro within the macro file) that runs each time you start **Draft** or **Edit Library**.

Figure 1-10. Macro Options area of Configure Schematic Design Tools screen.

With macros you can dramatically reduce the number of keystrokes required to perform complex or repetitive actions. Macro files can contain many macros. Macro file size is limited by the size of the macro buffer (defined in the **Macro Buffer Size** entry field, described below).

To help you use macros right away, the **Schematic Design Tools** master disks contain two OrCAD-supplied macro files, **MACRO1.MAC** and **MACRO2.MAC**. These macro files are a useful starter set for **Draft**. Note that they are not designed for **Edit Library**. **MACRO1.MAC** and **MACRO2.MAC** reside in the **TEMPLATE** directory. They are copied to each new design you create.

### Macro Buffer Size

The macro buffer is the storage location for macros read in from a file or created but not written to a file. The amount of memory allocated to the macro buffer is entered in the **Macro Buffer Size** entry box. The minimum memory size for the macro buffer is 8192 bytes; the maximum is 65,535 bytes.

*Example* In the example below, the macro buffer is set at its minimum size.

Macro Buffer Size

**Draft Macro File and Edit Library Macro File**

The macro file is the path and filename of the macro file to load automatically whenever you run **Draft** or **Edit Library**.

To define a macro file, enter the path and filename of the macro file in the **Draft Macro File** or **Edit Library Macro File** entry box. If the macro file is not in the design directory, you must specify a full pathname to the macro file. After you create and save your own macro files, its name can be entered here for automatic loading.

*Example*

The example below tells **Draft** to look for the macro file named **MACRO1.MAC** on the C: hard disk in the **\ORCAD\TEMPLATE** directory.

Draft Macro File

**Draft Initial Macro and Edit Library Initial Macro**

The initial macro is a keystroke that **Draft** or **Edit Library** issues automatically whenever you run the respective program. This keystroke should be one defined to run a particular macro. For the initial macro to work, a filename (containing the desired macro definition) must be defined in the **Macro File** entry box.

If a filename is not entered in the **Macro File** entry box, the **Initial Macro** entry box is dim.

*Examples*

The example below tells **Draft** to execute the macro assigned to function key **<F1>** automatically whenever you run **Draft**. To enter **<F1>**, type **<F>** and then **<1>**.

Draft Initial Macro

If the macro you want for the initial macro runs when you press the keys **<Ctrl>** and **<A>** simultaneously, represent the **<Ctrl>** key with the *caret* character (**^**), which you type by pressing **<Shift> <6>**. Enter the characters **<^> <A>** in the **Draft Initial Macro** entry box:

Draft Initial Macro

For more information, see the **MACRO** command description in *Chapter 2: Draft*.

## Hierarchy Options

**Hierarchy Options** (figure 1-11) defines the size of the hierarchy buffer.

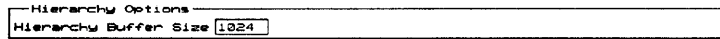

*Figure 1-11. Hierarchy Options area of the Configure Schematic Design Tools screen.*

## Hierarchy Buffer Size

All hierarchical sheet and pathnames are stored in the hierarchy buffer. The amount of memory allocated to the hierarchy buffer is entered in the **Hierarchy Buffer Size** entry box.

The minimum memory size is 1024 bytes, which allows you to create a hierarchical depth of about 75 to 100 worksheets (depending on sheet and pathname character lengths).

You can increase the size of the hierarchy buffer to 65,535 bytes, large enough for a hierarchical depth of over 200 worksheets.

*Example* The hierarchy buffer is set at its minimum size.

Hierarchy Buffer Size



## Color and Pen Plotter Table

The Color and Pen Plotter Table (figure 1-12) selects the screen display and plotter pen colors for library parts, pin numbers and names, wires, buses, junctions, connectors, and other objects in the worksheet. The objects are listed in the left column of the table.

| Color and Pen Plotter Table |                       |        |                      |
|-----------------------------|-----------------------|--------|----------------------|
| Part Body                   | <input type="radio"/> | Pen 1  | Width .010 Speed DEF |
| Pin Number                  | <input type="radio"/> | Pen 1  | Width .010 Speed DEF |
| Pin Name                    | <input type="radio"/> | Pen 1  | Width .010 Speed DEF |
| Part Reference              | <input type="radio"/> | Pen 1  | Width .010 Speed DEF |
| Part Value                  | <input type="radio"/> | Pen 1  | Width .010 Speed DEF |
| 1st Part Field              | <input type="radio"/> | Pen 1  | Width .010 Speed DEF |
| 2nd Part Field              | <input type="radio"/> | Pen 1  | Width .010 Speed DEF |
| 3rd Part Field              | <input type="radio"/> | Pen 1  | Width .010 Speed DEF |
| 4th Part Field              | <input type="radio"/> | Pen 1  | Width .010 Speed DEF |
| 5th Part Field              | <input type="radio"/> | Pen 1  | Width .010 Speed DEF |
| 6th Part Field              | <input type="radio"/> | Pen 1  | Width .010 Speed DEF |
| 7th Part Field              | <input type="radio"/> | Pen 1  | Width .010 Speed DEF |
| 8th Part Field              | <input type="radio"/> | Pen 1  | Width .010 Speed DEF |
| Wire                        | <input type="radio"/> | Pen 1  | Width .010 Speed DEF |
| Bus                         | <input type="radio"/> | Pen 1  | Width .010 Speed DEF |
| Junction                    | <input type="radio"/> | Pen 1  | Width .010 Speed DEF |
| Power Object                | <input type="radio"/> | Pen 1  | Width .010 Speed DEF |
| Power Text                  | <input type="radio"/> | Pen 1  | Width .010 Speed DEF |
| Sheet Body                  | <input type="radio"/> | Pen 1  | Width .010 Speed DEF |
| Sheet Name                  | <input type="radio"/> | Pen 1  | Width .010 Speed DEF |
| Sheet Net                   | <input type="radio"/> | Pen 1  | Width .010 Speed DEF |
| Module Port                 | <input type="radio"/> | Pen 1  | Width .010 Speed DEF |
| Module Text                 | <input type="radio"/> | Pen 1  | Width .010 Speed DEF |
| Label                       | <input type="radio"/> | Pen 1  | Width .010 Speed DEF |
| Comment Text                | <input type="radio"/> | Pen 1  | Width .010 Speed DEF |
| Dashed Line                 | <input type="radio"/> | Pen 1  | Width .010 Speed DEF |
| Title Block                 | <input type="radio"/> | Pen 1  | Width .010 Speed DEF |
| Title Text                  | <input type="radio"/> | Pen 1  | Width .010 Speed DEF |
| Command Prompt              | <input type="radio"/> | Pen 1  | Width .010 Speed DEF |
| Grid Dots                   | <input type="radio"/> | Pen 1  | Width .010 Speed DEF |
| Trace Object                | <input type="radio"/> | Pen 99 | Width Speed          |
| Test Vector Obj.            | <input type="radio"/> | Pen 99 | Width Speed          |
| Stimulus Object             | <input type="radio"/> | Pen 99 | Width Speed          |
| Error Object                | <input type="radio"/> | Pen 99 | Width Speed          |
| No Connect Obj.             | <input type="radio"/> | Pen 1  | Width .010 Speed DEF |
| Layout Object               | <input type="radio"/> | Pen 99 | Width Speed          |
| Sheet Filename              | <input type="radio"/> | Pen 1  | Width .010 Speed DEF |

Figure 1-12. Color and Pen Plotter Table area of the Configure Schematic Design Tools screen.

**Color** To change an item's color, simply select the desired color.

**Pen** To select a pen, enter its number in the Pen entry box for the desired object. Valid entries are:

**1-16** Valid pen numbers

**0** Causes the plotter to pause so you can change pens

**99** Causes the plotter to not plot the object

*Examples* Here are some examples showing how to set configuration to suppress plotting the title block's lines, text, or both.

### *Suppressing title block lines*

To suppress title block lines and leave title block text on the worksheet, enter **99** in the **Pen** entry box to the right of **Title Block**.

When you open a worksheet in **Draft**, the title block lines still display. However, they do not appear on the plot, as shown in the figure below.

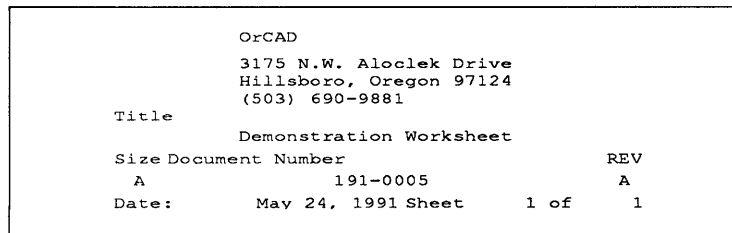

Figure 1-13. Plot of a title block with lines suppressed.

△ **NOTE:** This also turns off the border around the drawing area during printing.

### *Suppressing title block text*

To suppress title block text and leave title block lines on the worksheet, enter **99** in the **Pen** entry box to the right of **Title Text**.

When you open a worksheet in **Draft**, the title block text still displays. However, it does not appear on the plot, as shown in the figure below.

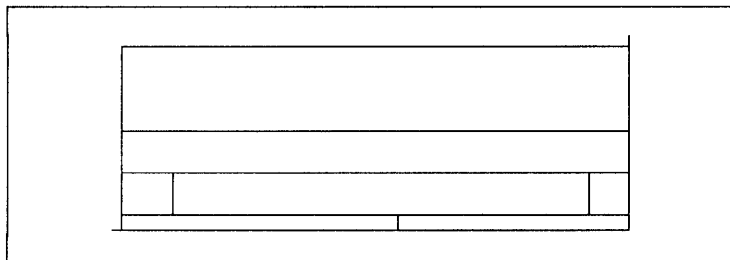

Figure 1-14. Plot of a title block with text suppressed.

*Suppressing title block lines and text*

There are two ways to suppress title block lines *and* text:

- ❖ Set both the title block and title text to a pen of **99**. Using this method, the title block and its text display on the screen, but do not appear on a plot.
- ❖ Use Draft's **SET Title Block No** command. If you use this method, the title block and its text do not display on the screen or appear on a print or a plot.

► *Helpful hint . . .*

If you are plotting on paper pre-printed with your title block, suppress the title block and its text as described above. Use Draft's **PLACE** command to place text in the correct position so that when you plot your schematic the text prints in the correct place in your pre-printed title block.

**Width** Pen width is the actual width of the pen the plotter uses to draw an object. **Plot Schematic** uses this value to calculate the number of pen strokes needed to create an object. The value is expressed in inches (0.010 is  $\frac{1}{100}$  of an inch).

If buses or object fills have white spaces when plotting, reduce the pen width to correct the condition. In some cases, the correct setting for your plotter can be determined only by experimentation.

**Speed** Enter the pen's velocity in the **Speed** entry box for the desired object. See your plotter manual to correctly set the speed. The value is expressed in units, a measurement determined arbitrarily by the plotter manufacturer.

Entering **DEF** in the **Speed** entry box tells **Plot Schematic** to use to your plotter's default speed. **Plot Schematic** makes no change to the pen speed.

**1st Part Field through  
8th Part Field**

The names used to label the **1st Part Field** through the **8th Part Field** can be changed. Look at the **Color and Pen Plotter Table**, and notice that the names **1st Part Field** through **8th Part Field** each have a box around them. This is because you can change these names. To do this, simply click inside the box and edit the name. The new name appears in **Draft** when using the **EDIT Part Name** command.

Look at the **Template Table** on the **Configure Schematic Design Tools** screen and notice that it also contains the **1st Part Field** through **8th Part Field** entry fields. If you change these headings in the **Color and Pen Plotter Table**, they are also changed in the **Template Table**.

## Template Table

The **Template Table** (figure 1-15) contains the global settings for the size (in inches or millimeters) of various parameters in schematics. This includes worksheet dimensions, text size, border size, pin-to-pin spacing, and so on.

**Draft** has five sheet sizes built in: A through E (American) or A4 through A0 (International Standards Organization). Using the **Template Table**, you can tailor the dimensions and many characteristics of each to match your requirements.

The maximum worksheet dimensions are 65 inches by 65 inches, including the border. Object scaling is controlled by the **Pin to Pin** values.

To change one of the values, simply click inside the appropriate entry box and edit the value.

| Template Table |   |        |                                   |        |        |
|----------------|---|--------|-----------------------------------|--------|--------|
| Units          | <input checked="" type="radio"/> Inches |        | <input type="radio"/> Millimeters |        |        |
|                | A                                       | B      | C                                 | D      | E      |
| Horizontal     | 9.700                                   | 16.200 | 20.200                            | 32.200 | 42.200 |
| Vertical       | 7.200                                   | 9.700  | 15.200                            | 20.200 | 32.200 |
| Pin-to-Pin     | .100                                    | .100   | .100                              | .100   | .100   |
| Pin Number     | .050                                    | .050   | .050                              | .050   | .050   |
| Pin Name       | .050                                    | .050   | .050                              | .050   | .050   |
| Part Reference | .050                                    | .050   | .050                              | .050   | .050   |
| Part Value     | .050                                    | .050   | .050                              | .050   | .050   |
| 1st Part Field | .050                                    | .050   | .050                              | .050   | .050   |
| 2nd Part Field | .050                                    | .050   | .050                              | .050   | .050   |
| 3rd Part Field | .050                                    | .050   | .050                              | .050   | .050   |
| 4th Part Field | .050                                    | .050   | .050                              | .050   | .050   |
| 5th Part Field | .050                                    | .050   | .050                              | .050   | .050   |
| 6th Part Field | .050                                    | .050   | .050                              | .050   | .050   |
| 7th Part Field | .050                                    | .050   | .050                              | .050   | .050   |
| 8th Part Field | .050                                    | .050   | .050                              | .050   | .050   |
| Power Text     | .050                                    | .050   | .050                              | .050   | .050   |
| Sheet Name     | .050                                    | .050   | .050                              | .050   | .050   |
| Sheet Net      | .050                                    | .050   | .050                              | .050   | .050   |
| Module Text    | .050                                    | .050   | .050                              | .050   | .050   |
| Label          | .050                                    | .050   | .050                              | .050   | .050   |
| Comment Text   | .050                                    | .050   | .050                              | .050   | .050   |
| Title Block    | .050                                    | .050   | .050                              | .050   | .050   |
| Border Text    | .050                                    | .050   | .050                              | .050   | .050   |
| X Border Width | .100                                    | .100   | .100                              | .100   | .100   |
| Y Border Width | .100                                    | .100   | .100                              | .100   | .100   |
| Plot X Offset  | .020                                    | .020   | .020                              | .020   | .020   |
| Plot Y Offset  | .020                                    | .020   | .020                              | .020   | .020   |
| Roll Form Size | .020                                    | .020   | .020                              | .020   | .020   |
| Spacing Ratio  | 1.333                                   | 1.333  | 1.333                             | 1.333  | 1.333  |

Figure 1-15. Template Table area of the Configure Schematic Design Tools screen.

**Units** Select either the **Inches** or **Millimeters** option to choose the unit of measure. If you select **Inches**, all measurements are shown in inches. Note also that the headings above each column are A, B, C, D, and E.

If you select **Millimeters**, all measurements are shown in millimeters. Note also that the headings above each column are A4, A3, A2, A1, and A0.

▲ **CAUTION:** *If you change from inches to millimeters or vice versa, all custom settings you may have made are lost, and the default settings for each item are restored.*

**Horizontal** Width (horizontal dimension) of the schematic worksheet working area. The maximum width allowed for a schematic worksheet is 65 inches.

**Vertical** Height (vertical dimension) of the schematic worksheet working area. The maximum height allowed for a schematic worksheet is 65 inches.

△ **NOTE:** *The following points refer to both the **Horizontal** and **Vertical** settings:*

*The border, if there is to be one, is drawn inside the rectangle defined by the horizontal and vertical dimensions.*

*The maximum worksheet dimensions are 65 inches by 65 inches, including the border. When you use **Plot Schematic** to print schematics it will only print schematics up to 32 inches by 32 inches in size. **Plot Schematic** scales anything larger to fit in these dimensions.*

**Pin-to-Pin** Determines the minimum distance between two pins on a part and also controls template size and object scaling. The default value (0.1 inch) is a half-size template; a full-size template results when the pin-to-pin spacing is set to 0.2 inch. It also changes the distance between grid dots.

|  |  |
|--|--|
| <b>Pin Number</b>                            | Height of a part's pin numbers. Because pin numbers appear between pins, do not make the pin number size greater than the pin-to-pin spacing.  |
| <b>Pin Name</b>                              | Height of a part's Pin Name characters.  |
| <b>Part Reference</b>                        | Height of a part's Part Reference characters.  |
| <b>Part Value</b>                            | Height of a part's Part Value characters.  |
| <b>1st Part Field through 8th Part Field</b> | <p>Height of the characters used to show the information contained in the part fields.</p> <p>Notice that the names <b>1st Part Field</b> through <b>8th Part Field</b> each have a box around them, indicating that you can change these names—just like in the <b>Color and Pen Table Plotter Table</b>.</p> <p>To change a name, simply click inside the box and edit the name. The new name appears in <b>Draft</b> when using the <b>EDIT Part Name</b> command.</p> <p>The <b>Color and Pen Plotter Table</b> on the <b>Configure Schematic Design Tools</b> screen also lists the <b>1st Part Field</b> through <b>8th Part Field</b> entry fields. Changing these headings in the <b>Template Table</b> also changes them in the <b>Color and Pen Plotter Table</b>.</p> |
| <b>Power Text</b>                            | Height of power object characters.   |
| <b>Sheet Name</b>                            | Height of sheet name characters.   |
| <b>Sheet Net</b>                             | Height of sheet net name characters.   |
| <b>Module Text</b>                           | Height of module port name characters.   |
| <b>Label</b>                                 | Height of label characters.  |

|  |  |
|--|--|
| <b>Comment Text</b>                            | Height of comment text characters.   |
| <b>Title Block</b>                             | Height of title block characters.  |
| <b>Border Text</b>                             | Height of the characters used to show text in the border. For readable results, do not make border text larger than the border width.  |
| <b>X Border Width</b><br><b>Y Border Width</b> | Width of the border around the worksheet. <b>Draft</b> draws the border inside the rectangle defined by the horizontal ( <b>X Border Width</b> ) and vertical ( <b>Y Border Width</b> ) dimensions. Grid references are shown inside the border.   |
| <b>Plot X Offset</b>                           | <p>Moves the origin horizontally. <b>Plot Schematic</b> uses the lower left corner of a sheet as its origin point when plotting. Some plotters (such as Hewlett-Packard C, D, and E size plotters) place the origin in the page's center, which results in the worksheet not plotting properly: the lower left corner of the worksheet is plotted in the center of the page. Use this entry box to compensate for this. The correct X offset can be calculated as shown below:</p> $\text{Plot X Offset} = -\frac{1}{2} \text{ page width}$ <p>△ <i>NOTE: This is a negative number.</i></p> |
| <b>Plot Y Offset</b>                           | <p>Moves the origin vertically. Use it to compensate for plotters that do not use the lower left corner as the origin point. The correct Y offset can be calculated as shown below:</p> $\text{Plot Y Offset} = -\frac{1}{2} \text{ page height}$ <p>△ <i>NOTE: This is a negative number.</i></p>   |
| <b>Roll Form Size</b>                          | Amount of paper to unroll from the spool when done plotting.   |



**Spacing Ratio** Determines the relationship between a character's vertical height and horizontal distance between the start of one character and the start of the next character:

$$\text{Spacing Ratio} = \frac{\text{Pin-to-pin spacing} * 0.08}{\text{Height (H)} * 0.1}$$

This is not the same as the character's aspect ratio, which is the relationship between a character's vertical height and its horizontal width.

$$\text{Aspect Ratio} = \frac{\text{Height (H)}}{\text{Width (W)}}$$

Changing the spacing ratio lets you fine-tune the appearance of plots when pin-to-pin spacing is changed.

For example, if pin-to-pin spacing is set to

0.2 inch (a full-size template), and text height set to 0.156 inch, the spacing ratio is 1.026. This gives a character spacing of 1.026 inch.

$$\text{Spacing Ratio} = \frac{0.2 * 0.08}{0.156 * 0.10} = 1.026$$

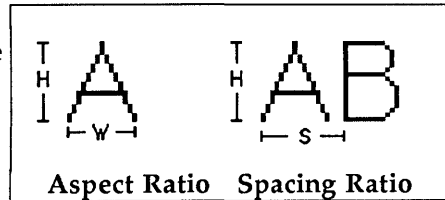

*Default settings*

Draft's default is a half-size template (with pin-to-pin spacing at 0.1 inch), all text sizes of 0.060 inch, and a spacing ratio of 1.333. This produces character spacing of 0.08 inch.

$$\text{Spacing Ratio} = \frac{0.1 * 0.08}{0.06 * 0.10} = 1.333$$

## Key Fields

To understand *key fields* and how to use them, you need to understand *part fields*.

Associated with every library part are ten *part fields*. A part field is a slot for holding text or data associated with that part. These fields can be accessed and edited after a part is placed in a design.

Two part fields are reserved for particular types of data:

- ❖ The **Reference** field is reserved for holding reference designator values, such as "U1A" or "Q1."
- ❖ The **Part Value** field is reserved for holding part names, such as "74LS04" or values relevant for the part, such as Ohm ( $\Omega$ ) values for resistors.

|                |
|----------------|
| Reference      |
| Part Value     |
| 1ST PART FIELD |
| 2ND PART FIELD |
| 3RD PART FIELD |
| 4TH PART FIELD |
| 5TH PART FIELD |
| 6TH PART FIELD |
| 7TH PART FIELD |
| 8TH PART FIELD |

To be processed correctly by **Schematic Design Tools**, every part (including parts not supplied by OrCAD) *must* have data in the **Reference** field and in the **Part Value** field. The only exceptions to this rule are objects whose only pin is of type POWER.

The other eight fields are named **1st Part Field** through **8th Part Field**.

△ **NOTE:** You can change the names used to identify **1st Part Field** through **8th Part Field**. See the section in this chapter about the **Color and Pen Plotter Table** and the **Template Table** for instructions on how to do this.

You can store any useful information in the eight part fields: tolerance, vendor name, part number, and so on. Each field can be up to 127 characters long. You can edit the contents of these fields and make them visible or invisible on the schematic using Draft's **EDIT** command. You can also use the **Select Field View** processor to make a part field visible or invisible for all parts in a design.

To perform special processing, **Draft** and several other **Schematic Design Tools** (that affect or use part field values) can combine and compare the information in these part fields. For example, the way **Annotate Schematic** designates parts for grouping in component packages can be changed. Or, **Create Bill of Materials** can list parts grouped by tolerance *and* value, rather than by value alone.

To tell **Draft** and the other tools which fields you want to combine and compare, *key fields* are used (figure 1-16). A key field lists the part fields to combine and compare. Key fields are specific to a particular tool. **Schematic Design Tools** has sixteen key fields: **Annotate Schematic** uses one key field; **Create Netlist** uses two; **Create Bill of Materials** uses two; **Update Field Contents** uses nine; and **Extract PLDs** uses two.

| Key Fields                      |                      |
|---------------------------------|----------------------|
| <b>Annotate Schematic</b>       |                      |
| Part Value Combine              | <input type="text"/> |
| <b>Update Field Contents</b>    |                      |
| Combine for Value               | <input type="text"/> |
| Combine for Field 1             | <input type="text"/> |
| Combine for Field 2             | <input type="text"/> |
| Combine for Field 3             | <input type="text"/> |
| Combine for Field 4             | <input type="text"/> |
| Combine for Field 5             | <input type="text"/> |
| Combine for Field 6             | <input type="text"/> |
| Combine for Field 7             | <input type="text"/> |
| Combine for Field 8             | <input type="text"/> |
| <b>Create Netlist</b>           |                      |
| Part Value Combine              | <input type="text"/> |
| Module Value Combine            | <input type="text"/> |
| <b>Create Bill of Materials</b> |                      |
| Part Value Combine              | <input type="text"/> |
| Include File Combine            | <input type="text"/> |
| <b>Extract PLD</b>              |                      |
| PLD Part Combine                | <input type="text"/> |
| PLD Type Combine                | <input type="text"/> |

Figure 1-16. Key Fields area of Configure Schematic Design Tools screen.

Key fields can contain:

- ❖ The character **R** to represent the value found in the **Reference** field.
- ❖ The character **V** to represent the value found in the **Part Value** field.
- ❖ The numerals **1** through **8** for the values found in **Part Fields 1** through **8**.
- ❖ Any combination of text (including blank spaces, commas, and other punctuation). Note that you cannot include **V** and **R** in a text string, as those are the characters used to represent the values found in the **Reference** and **Part Value** fields. You can, however, use **v** and **r** in a text field.

The total length of a key field combination should not exceed 127 characters. For example, if your key field characters are **V,1** the total length of the data stored in the **Part Value** field plus the data in the **1st Part Field**, plus the comma cannot be longer than 127 characters.

Now you know how to specify values in the key fields. The next sections explain the different types of key fields, what they do, and how to use them.

**Annotate Schematic  
Part Value Combine**

When you run **Annotate Schematic** on a schematic design, it puts a reference designator value in the **Reference** field of each part.

Some parts come in packages containing more than one part. For example, the 7439 package contains four two-input NAND buffers. When annotating schematics with parts that come in packages containing multiple parts, **Annotate Schematic** groups parts with the same value in their **Part Value** fields in the same package (until the package is full). **Annotate Schematic** creates reference designator values naming first the packages the parts come in and then the occurrence of the part within the package.

For example, suppose a design contains six parts with values of "74LS08" in their **Part Value** fields, and the part library specifies these parts are bundled four per package.

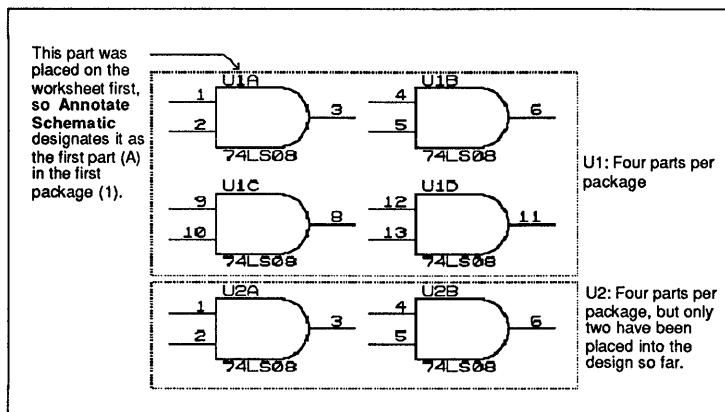

Figure 1-17. How **Annotate Schematic** normally assigns reference designators.

When you run **Annotate Schematic** on this design, it assigns reference designators (such as U1A, U1B, U1C, U1D, U2A and U2B) to these parts (figure 1-17). U1 names one package and U2 names a second; the letters A–D name the particular parts within each package. Reference designators are assigned to parts in the order in which you placed them on the worksheet. In this example, the first 74LS08 placed in the worksheet is numbered U1A and the last one placed U2B.

Suppose for physical layout reasons you want to partition the circuit to group these six parts differently. You want three of them in one package, and three in another. This is where Annotate Schematic's key field comes in handy.

First designate which portion of the circuit each part is to be grouped in. Assign the value "MOD\_1" or "MOD\_2" to the 1st Part Field of every part in the design using Draft's EDIT Part command (figure 1-18). If your worksheet is crowded, hide the information from view by making the field invisible. For more information, see Chapter 12: *Select Field View*.

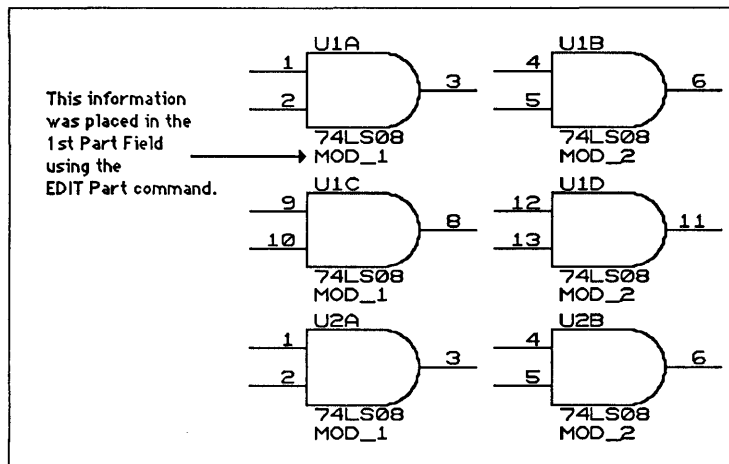

Figure 1-18. Parts with 'MOD\_1' and 'MOD\_2' values assigned to 1st Part Field.

Next, configure the key field for Annotate Schematic so that it carries out this scheme in the way it assigns reference designators. In the Key Field area of the Configure Schematic Design Tools screen, enter the characters V 1 into the Annotate Part Value Combine edit field. For example:

Annotate Part Value Combine

From now on, when **Annotate Schematic** assigns reference designators to parts in a design, it will not group parts (that come several per package) in the same package unless they have the same **Part Value** *and* the same value in **Part Field 1**.

So, if on three of the 74LS08's, you place the value "MOD\_1" in **Part Field 1**, and on the other three 74LS08's you placed the value "MOD\_2" in **Part Field 1**, **Annotate Schematic** assigns each set of three its own package. The reference designators for one set would be something like U1A, U1B and U1C, and the reference designators for the other set would be something like U2A, U2B and U2C.

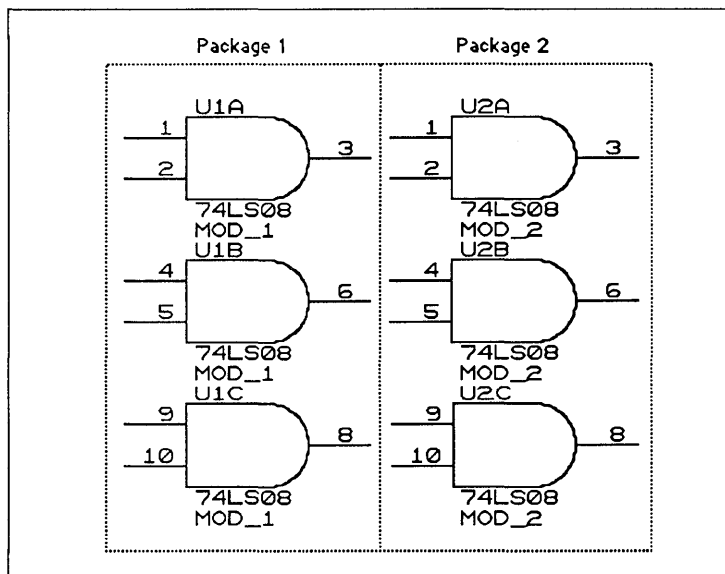

Figure 1-19. Annotate Schematic assigned reference designators based on Part Value (74LS08) and 1st Part Field data.

**Update Field Contents  
Combine for  
Value and Field 1  
through Field 8**

To understand how these key fields work, you must understand how **Update Field Contents** works.

**Update Field Contents** is a search and replace tool. It looks for data (called a match string) and when it finds a match, it replaces the data with new data.

**Update Field Contents** can update nine of the ten part fields. The **Reference** field is protected and cannot be updated with **Update Field Contents**. (You *can* change the **Reference** field using **EDIT Reference in Draft**.) You can use the **Reference** field as part of the match string, however. You use key fields to tell **Update Field Contents** where to look for data, and a text file (called an *update file*, usually with an extension of **.UPD**) to tell **Update Field Contents** what to do when it finds a match.

When you run **Update Field Contents**, you specify which field to update. Only one field can be updated at a time. Each update field can have its own separate search criteria, so there are nine sets of key fields for **Update Field Contents** listed on the **Configure Schematic Design Tools** screen. They all work the same way.

*Looking up match  
values*

**Update Field Contents** uses the entries you make in the **Combine for Value/Field** key fields to construct a text string called a *match string*.

For example, if you specify **Part Field 2** as the destination, **Update Field Contents** looks at the entry in **Combine for Field 2**. Suppose the characters **V 1** are entered there.

*For each part in the design, Update Field Contents builds a text string from the value found in the part's Part Value field, a blank space, and the value found in the part's 1st Part Field.*

For example, if a part has a value of "74LS04" in its **Part Value** field, and a value of "14DIP300" in its **1st Part Field**, **Update Field Contents** builds the string:

74LS04 14DIP300

Then, **Update Field Contents** compares this match string to the first text string of each pair of text strings it finds in the specified update file.



An update file consists of lists of strings. Each string in the update file is enclosed by single quotation marks, like this:

```
'74LS04 14DIP300'      '14 pin Inverter Package'  
'74LS138 16DIP130'    '16 pin Inverter Package'
```

△ **NOTE:** You can use either single quotes (') or double quotes (") to indicate a text string. You can also use single and double quotes together on the same line to indicate an apostrophe. For example: '10H8' "NATL'PAL10H8"  
You can include comments in an update file by enclosing the comments in curly braces ({}).

**Update Field Contents** looks at the strings in the stuff file in pairs, and so for readability and clarity, each pair is usually placed on a separate line in the stuff file. The first string in each pair is the *lookup match string*. The second string is what **Update Field Contents** places into the update part field when it finds a match.

Using the example above, suppose there is a line in the specified update file that contains this pair of strings:

```
'74LS04 14DIP300'      '14 pin Inverter Package'
```

**Update Field Contents** puts the text, "14 pin Inverter Package" into the **2nd Part Field** of a part whose **Part Value** field reads "74LS04" and whose **1st Part Field** reads "14DIP300".

For more information on **Update Field Contents**, see *Chapter 13: Update Field Contents*.

**Create Netlist  
Part Value Combine**

Configuring this key field tells **Create Netlist** and **Create Hierarchical Netlist** to read the **Part Value** (or combination of values) in the **Netlist Part Value** field for each part in the design and use this as the **Part Value** for each part in the netlist. Generally, you should leave this field set to "V" for most netlist formats.

What value, if any, you should substitute for the **Part Value** depends on the netlist format you want to produce. Different applications require netlists with different types of values in the netlist's **Part Value** position.

**Create Netlist  
Module Value Combine**

This key field tells **Create Netlist** and **Create Hierarchical Netlist** to create a *module value* to show the name of the module to be used for layout. Most layout products refer to the pad shape separately from the part value.

For example, a 74LS00 comes in a 14 pin 0.300-inch center DIP package or in a surface mount package. Accordingly, the *module value* is used to indicate the package type so the layout can have the correct pad shape.

What value, if any, you create for the *module value* depends on the particular netlist format you want to produce. Different applications require netlists with different types of module values.

If you do not specify this key field, the *module value* will be the **Part Value** field.



**NOTE:** *Schematic Design Tools* includes an update file that does some of the assignments for *PC Board Layout Tools*.

**Create Bill of  
Materials  
Part Value Combine**

To understand how this key field works, you must understand how **Create Bill of Materials** works.

**Create Bill of Materials** creates a list of the parts placed in a specified design. It uses the values found in the **Part Value** field of each part to determine whether parts are the same or different. **Create Bill of Materials** lists the parts it identifies as the same on the same line.

Configuring this key field instructs **Create Bill of Materials** to read the **Part Value** (or combination of values) in the **Combine Field** for each part in the design and use this as the **Part Value** for each part in the Bill of Materials. Generally, you should leave this field set to "V" (for Value) for most Bill of Materials formats. An example of how to use this key field follows.

**Create Bill of  
Materials  
Include File Combine**

The **Bill of Materials Include File Combine** key field is used to determine how the match string in the include file is applied to the schematic.

For example, if you want the values in the include file to be matched to the contents of **Part Field 6**, you enter 6 in this key field.

*Example*

In a design, you placed several capacitors, all with the value of 50pF in their **Part Value** fields. Some of them are made of a plastic material and others of a ceramic. You want the part list to show this distinction.

To do this, edit **Part Field 1** on the plastic capacitors to hold the value "Plastic," and edit **Part Field 1** on the ceramic capacitors to hold the value "Ceramic." Then, in **Key Fields** area, enter the number 1 in the **Bill of Materials Include File Combine** entry box.

When **Create Bill of Materials** runs on the design, all capacitors with a **Part Field 1** value of "Plastic" and a **Part Value** of "50pF" appear on one line of the part list, and all capacitors with a **Part Field 1** value of "Ceramic" and a **Part Value** of "50pF" appear on a different line of the part list.

**Extract PLD  
PLD Part Combine  
and PLD Type  
Combine**

Use these key fields in conjunction with **Extract PLD**, one of the processes in the **To PLD transfer to Programmable Logic Design Tools**. **Extract PLD** extracts information from a schematic for use with OrCAD's programmable logic device compiler and places it in a .PLD file. The **PLD Part Combine** data is placed immediately after the word "Part:" following the pin information in the .PLD file. The **PLD Type Combine** data is placed immediately after the word "Type:" in the .PLD file.

*Example* The next example shows how these key fields are used by **Extract PLD**. Figure 1-20 shows part of a design with a PLD.

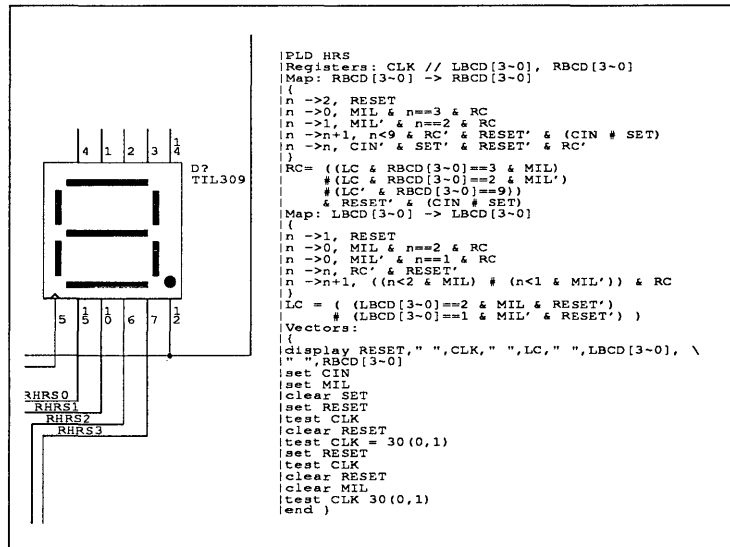

Figure 1-20. Programmable logic device.

Assume the **Extract PLD** key fields are configured as shown below.

Extract PLD  
 PLD Part Combine   
 PLD Type Combine

When you run **Extract PLD** on the schematic containing the part, it creates a file called HRS.PLD. The contents of HRS.PLD are shown in figure 1-21. In the HRS.PLD output, the **PLD Type Combine** key field (1st Part Field) is shown in *bold italics*, and the **PLD Part Combine** key field (2nd Part Field) is shown in **bold**.

```
|"HRS"  1:CLK,
|       2:-,
|       3:-,
|       4:-,
|       5:-,
|       6:-,
|       7:-,
|       8:-,
|       9:MIL,
|      10:SET,
|      11:CIN,
|      13:RESET,
|      23:LC,
|      22:LBCD3,
|      21:LBCD2,
|      20:LBCD1,
|      19:LBCD0,
|      18:RC,
|      17:RBCD3,
|      16:RBCD2,
|      15:RBCD1,
|      14:RBCD0
|
|Value:  "HRS"
|Type:   "22V10"
|Part:   "PALC22V10-35"
|Library: "EXAMPLE.LIB"
|
|Title:  "Example schematic"
|Title:  " November 5, 1990"
|
|Registers: CLK // LBCD[3~0], RBCD[3~0]
|Map: RBCD[3~0] -> RBCD[3~0]
|{
|n ->2, RESET
|n ->0, MIL & n==3 & RC
|n ->1, MIL' & n==2 & RC
|n ->n+1, n<9 & RC' & RESET' & (CIN # SET)
```

Figure 1-21. Extract PLD output (continued on next page).

```

|n ->n, CIN' & SET' & RESET' & RC'
|}
|RC= ((LC & RBCD[3~0]==3 & MIL)
|   #(LC & RBCD[3~0]==2 & MIL')
|   #(LC' & RBCD[3~0]==9))
|   & RESET' & (CIN # SET)
|Map: LBCD[3~0] -> LBCD[3~0]
|{
|n ->1, RESET
|n ->0, MIL & n==2 & RC
|n ->0, MIL' & n==1 & RC
|n ->n, RC' & RESET'
|n ->n+1, ((n<2 & MIL) # (n<1 & MIL')) & RC
|}
|LC = ( (LBCD[3~0]==2 & MIL & RESET')
|       # (LBCD[3~0]==1 & MIL' & RESET')) )
|Vectors:
|{
|display RESET," ",CLK," ",LC," ",LBCD[3~0], \
|" ",RBCD[3~0]
|set CIN
|set MIL
|clear SET
|set RESET
|test CLK
|clear RESET
|test CLK = 30(0,1)
|set RESET
|test CLK
|clear RESET
|clear MIL
|test CLK 30(0,1)
|end }

```

Figure 1-21. Extract PLD output (continued from previous page).

## Check Electrical Rules Matrix

The Check Electrical Rules matrix summarizes the rules that Check Electrical Rules uses when testing connections between pins, module ports, and sheet nets. This matrix is shown in figure 1-22.

The pins, module ports, and sheet nets are listed in columns and rows in the table. A test is represented by the intersection of a row and column. The intersection of a row and column is either empty, or contains a "W" or an "E". An empty intersection represents a valid connection, a W is a warning, and an E represents an error. You can toggle between these three settings by pointing to an intersection and clicking the mouse until the desired setting appears. To return all intersections to their default settings, select the Set to Defaults option.

Connections prefixed with an "m" are module ports. There are four types of module ports: input (mI), output (mO), bidirectional (mB), and unspecified (mU).

Connections prefixed with an "s" are sheet nets. As with module ports, there are four types of sheet nets: input (sI), output (sO), bidirectional (sB), and unspecified (sU).

Check Electrical Rules Matrix

|                           |     | i | o | o | o | p | h | o | p | m | m | m | s | s | s | s | N |
|---------------------------|-----|---|---|---|---|---|---|---|---|---|---|---|---|---|---|---|---|
|                           |     | i | o | o | o | p | h | o | p | m | m | m | s | s | s | s | N |
|                           |     | n | / | u | c | a | s | e | r | I | O | B | U | I | O | B | U |
|                           |     | o | u | c | a | s | e | r | r | O | B | U | I | O | B | U | C |
|                           |     | u | t | c | a | s | e | r | r | O | B | U | I | O | B | U | C |
| Input Pin                 | in  |   |   |   |   |   |   |   |   |   |   |   |   |   |   |   |   |
| Input/Output Pin          | i/o |   |   |   |   |   |   |   |   |   |   |   |   |   |   |   |   |
| Output Pin                | out |   |   |   |   |   |   |   |   |   |   |   |   |   |   |   |   |
| Open Collector Pin        | oc  |   |   |   |   |   |   |   |   |   |   |   |   |   |   |   |   |
| Passive Pin               | pas |   |   |   |   |   |   |   |   |   |   |   |   |   |   |   |   |
| High Impedance Pin        | hiz |   |   |   |   |   |   |   |   |   |   |   |   |   |   |   |   |
| Open Emitter Pin          | oe  |   |   |   |   |   |   |   |   |   |   |   |   |   |   |   |   |
| Power Pin on Object       | pur |   |   |   |   |   |   |   |   |   |   |   |   |   |   |   |   |
| Input Module Port         | mI  |   |   |   |   |   |   |   |   |   |   |   |   |   |   |   |   |
| Output Module Port        | mO  |   |   |   |   |   |   |   |   |   |   |   |   |   |   |   |   |
| Bidirectional Module Port | mB  |   |   |   |   |   |   |   |   |   |   |   |   |   |   |   |   |
| Unspecified Module Port   | mU  |   |   |   |   |   |   |   |   |   |   |   |   |   |   |   |   |
| Input Sheet Net           | sI  |   |   |   |   |   |   |   |   |   |   |   |   |   |   |   |   |
| Output Sheet Net          | sO  |   |   |   |   |   |   |   |   |   |   |   |   |   |   |   |   |
| Bidirectional Sheet Net   | sB  |   |   |   |   |   |   |   |   |   |   |   |   |   |   |   |   |
| Unspecified Sheet Net     | sU  |   |   |   |   |   |   |   |   |   |   |   |   |   |   |   |   |
| Unconnected               | NC  |   |   |   |   |   |   |   |   |   |   |   |   |   |   |   |   |

Figure 1-22. Check Electrical Rules Matrix area on the Configure Schematic Design Tools screen.

For definitions of pin types, see the PIN Type command description in Chapter 2: Draft.

**Example** To find the test result value when an output pin is connected to an input pin, use the OUT column (the third column in figure 1-20) and the IN row (the first row). This intersection is empty, which means this type of connection is acceptable. However, if you look at the intersection of the OUT column and the OUT row (the third row), you see an E, which indicates an output pin connected to an output pin is considered an error.





# P A R T I I : E D I T O R S

---

The heart of **Schematic Design Tools** is **Draft**, an Editor you use to create or modify schematics. You also use editors to edit or view text files and to access files containing reference information.

Part II describes Editor tools and provides instructions for their use.

- Chapter 2:* *Draft* explains how to configure and run **Draft**. An alphabetical command reference gives detailed descriptions of each of **Draft's** commands.
- Chapter 3:* *Guidelines for creating netlist connections* explains how to name signals, place labels, handle module ports, buses, and power objects correctly so that when a netlist is produced (using **Create Netlist** or **Create Hierarchical Netlist**) satisfactory results are achieved.
- Chapter 4:* *Edit File* explains how to use **Edit File** to run the text editor of your choice.
- Chapter 5:* *View Reference* describes how to use **View Reference** to read supplemental reference material provided by OrCAD.





## *Draft*

This chapter contains information needed to run **Draft**, the schematic editor at the heart of **Schematic Design Tools**.

Within this chapter you will find execution and local configuration information, and a complete command reference. In the command reference section, commands are described in the order in which they appear in **Draft's** main menu.

---

### Execution

With the **Schematic Design Tools** screen displayed, select **Draft**. Select **Execute** from the menu that displays.

- ❖ If you have not specified a source file on **Draft's** local configuration screen, **Draft** prompts:

load file?

Enter the name of the worksheet to create or edit.

- ❖ If you have specified a source file in **Draft's** local configuration, **Draft** loads the worksheet.

For instructions on how to specify a source file in **Draft's** local configuration, see the next section of this chapter.

- △ **NOTE:** *Schematic Design Tools* sets the root schematic of a design to the source file specified on **Draft's** local configuration screen.

For information about **Draft's** commands, see the *Command reference* section in this chapter.

## Local Configuration

With the Schematic Design Tools screen displayed, select Draft. A menu displays. Select **Local Configuration**.

Select **Configure Draft**. Draft's configuration screen displays (figure 2-1).

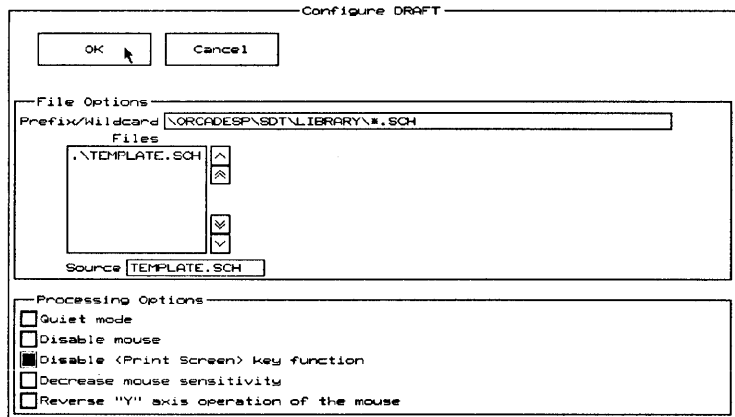

Figure 2-1. Draft's local configuration screen.

**File Options** File Options specifies a worksheet for Draft to load.

*Prefix/Wildcard* Enter a prefix and wildcard. These are described in the *OrCAD/ESP Design Environment User's Guide*. A list of files that match the selection criteria in this entry box displays in the Files list box.

*Files* This box contains a list of the files matching the search filter entered in the **Prefix/Wildcard** entry box and those matching the filter in the current design directory. Files in the current directory have .\ before their names. Use the scroll buttons to scroll the list of files up and down.

When you see the file you would like to open, select it. Its filename displays in the **Source** entry box.

*Source* The **Source** is the filename of a worksheet to load. Either select a worksheet from the **Files** list box or enter the path and name of the worksheet. When running under ESP, the source file is the root of the design.

△ **NOTE:** *If you do not enter a source name, Draft requests a filename when you run Draft.*

**Processing Options** You may select any combination of the following options:

- Quiet mode  
Turns quiet mode on.
- Disable mouse  
Disables the mouse. This option is normally used when debugging mouse problems while working with OrCAD Technical Support. It may also be required when running on older PC-compatible computers.
- Disable <Print Screen> key function  
Disables Draft's <Print Screen> key function. Use this option when you run other applications (usually RAM-resident) that use the <Print Screen> key. If this option is *not* selected, Draft uses the <Print Screen> key to capture hard copy output and blocks other uses.
- Decrease mouse sensitivity  
Slows the mouse down. Used for mouse devices that are too sensitive. For example, if you move your mouse a small distance and the pointer moves a large distance on the screen, select this option to make the pointer movement respond more closely to the mouse movement.
- Reverse "Y" axis operation of mouse  
Causes the mouse to respond differently. If this option is selected, the pointer moves up when you pull the mouse toward you, and moves down when you push the mouse away from you.

## Command reference

The remainder of this chapter is a command reference for **Draft**, the schematic editor. Commands are described in the order in which they appear in **Draft's** main menu.

Commands are described in alphabetical order, the order in which they appear in **Draft's** main menu. Main menu commands appear at the top of the first page describing the command. Many commands display other menus.

Commands on these menus are described under the main menu command.

Some commands in the main menu appear in several other menus. These commands (such as **FIND**, **JUMP**, and **ZOOM**) are described at the main menu level only. When a command occurs in another menu, see the main menu description of the command for an explanation of its use.

### Selecting commands

Select **Draft** commands in one of two ways:

- ❖ Press the first letter of the command name. Occasionally a menu has more than one command beginning with the same letter. When this happens, use the method of selecting commands explained below.
- ❖ Move the highlight bar over the command name, and press <Enter> or click the left mouse button.

Press <Esc> to return to the previous menu.

### Locating commands

If you are not sure of the name of a command, use table 2-1 to quickly look up the command alphabetically or use table 2-2 to identify the task you want to accomplish and then identify the command.

Once you know the name of the command, look it up in the command reference.

| <i>Command</i>    | <i>Menu commands</i>   |   |   |
|-------------------|--|---|---|
| <b>AGAIN</b>      | <i>None</i>  |   |   |
| <b>BLOCK</b>      | Move<br>Drag<br>Fixup  | Get<br>Save<br>Import   | Export<br>ASCII Import<br>Text Export                                     |
| <b>CONDITIONS</b> | Active Library<br>Macro Buffer                                     | Reference Library<br>Hierarchy Buffer                                     | Worksheet Memory<br>Size  |
| <b>DELETE</b>     | Object   | Block   | Undo  |
| <b>EDIT</b>       | Edit<br>Find   | Jump<br>Zoom  |   |
| <b>FIND</b>       | <i>None</i>  |   |   |
| <b>GET</b>        | <i>None</i>  |   |   |
| <b>HARDCOPY</b>   | Destination<br>File Mode   | Make Hardcopy<br>Width of Paper   |   |
| <b>INQUIRE</b>    | <i>None</i>  |   |   |
| <b>JUMP</b>       | A-H tags<br>Reference  | X location<br>Y location  |   |
| <b>LIBRARY</b>    | Directory  | Browse  |   |
| <b>MACRO</b>      | Capture<br>Delete  | Initialize<br>List  | Read<br>Write   |
| <b>PLACE</b>      | Wire<br>Bus<br>Junction<br>Entry (Bus)<br>Label                    | Module Port<br>Power<br>Sheet<br>Text<br>Dashed Line                      | Trace Name<br>Vector<br>Stimulus<br>NoConnect<br>Layout                   |
| <b>QUIT</b>       | Enter Sheet<br>Leave Sheet<br>Update File                          | Write to File<br>Initialize<br>Suspend to System                          | Abandon Edits<br>Run User Commands  |
| <b>REPEAT</b>     | <i>None</i>  |   |   |
| <b>SET</b>        | Auto Pan<br>Backup File<br>Drag Buses<br>Error Bell<br>Left Button | Macro Prompts<br>Orthogonal<br>Show Pins<br>Title Block<br>Worksheet size | X, Y Display<br>Grid Parameters<br>Repeat Parameters<br>Visible Lettering |
| <b>TAG</b>        | A-H tags   |   |   |
| <b>ZOOM</b>       | Center<br>In   | Out<br>Select   |   |

Table 2-1. Draft menu commands.



| <i>Category</i>                       | <i>Task</i>  | <i>Select</i>     |
|---------------------------------------|--|-------------------|
| Entering and editing objects and data | Put parts, connections, and hierarchical sheets on your worksheet.                                 | <b>PLACE</b>      |
|                                       | Get parts from loaded libraries.   | <b>GET</b>        |
|                                       | Edit or change parts on the worksheet.   | <b>EDIT</b>       |
|                                       | Identify and change a section of the worksheet.  | <b>BLOCK</b>      |
|                                       | Erase objects or blocks of objects.  | <b>DELETE</b>     |
| Setting locations and conditions      | Set the status of Draft parameters.  | <b>SET</b>        |
|                                       | Identify and remember locations on the worksheet.  | <b>TAG</b>        |
| Navigating on the screen              | Move the pointer to a specified location on the worksheet.   | <b>JUMP</b>       |
|                                       | Locate a string of text characters.  | <b>FIND</b>       |
|                                       | Change the location and amount of detail you see on the screen.                                    | <b>ZOOM</b>       |
| Repeating repetitive or complex tasks | Repeat the last main menu command.   | <b>AGAIN</b>      |
|                                       | Define macros (recorded commands).   | <b>MACRO</b>      |
|                                       | Duplicate the last entered object, label, or text string.  | <b>REPEAT</b>     |
| Showing status or other information   | Display part list directories and parts in loaded libraries.                                       | <b>LIBRARY</b>    |
|                                       | Display memory available for the worksheet, hierarchy buffer, and macro buffer.                    | <b>CONDITIONS</b> |
|                                       | Display text associated with worksheet objects.  | <b>INQUIRE</b>    |
| Printing your schematic               | Send a schematic to the printer or a file.   | <b>HARDCOPY</b>   |
| Leaving the program                   | Save your worksheet, enter or leave hierarchical worksheets, leave the root sheet, or leave Draft. | <b>QUIT</b>       |

*Table 2-2. Draft commands by function.*

---

## **AGAIN**

**AGAIN** repeats the last *main menu* command executed. For example, if the last command you selected is **PLACE**, you may repeat **PLACE** by selecting **AGAIN**.

**AGAIN** repeats commands only from the main menu. For example, if you execute a command in the **PLACE** menu and then select **AGAIN**, the **PLACE** menu displays, ready for you to select another **PLACE** command.

## **BLOCK**

Use **BLOCK** and its commands to manipulate specific areas of your worksheet. Select **BLOCK** to move, rubberband (stretch), make orthogonal (perpendicular to each other), duplicate, import, or export a section of a worksheet.

When you select **BLOCK**, the menu shown at right displays. The commands on this menu are described on the following pages.

### Block

|              |
|--------------|
| Move         |
| Drag         |
| Fixup        |
| Get          |
| Save         |
| Import       |
| Export       |
| ASCII Import |
| Text Export  |

**BLOCK Move** **BLOCK Move** moves selected objects to another location on the worksheet.

Select **BLOCK Move**. **Draft** displays:

```
Begin Find Jump Zoom
```

To select the objects to move, draw a box around them. Place the pointer where you want the corner of the box to start and select **Begin**. The **Begin** command in the command line is replaced with **End**:

```
End Find Jump Zoom
```

Move the pointer. As you do, **Draft** draws a box. When the box encloses or intersects all of the objects you wish to move, select **End**. **Draft** selects the objects and displays:

```
Place Find Jump Zoom
```

You can now move objects within or intersected by the box. The objects are drawn as outlined symbol shapes so that **Draft** can move them quickly. If you selected an area that contains many objects, only the box enclosing the area appears to move. **Draft** keeps the details of the objects in the box and displays them again when you place them in the new location.

Move the box to the new location. The objects within the area being moved still show at their original location. Only the outlined symbols within the selected area move.

Select **Place** to place the moved objects at the new location. **Draft** redraws the screen, placing the objects in their new location. **Draft** returns to the main menu level.

△ *NOTE: You may move and place a single object by selecting **BLOCK Move**, positioning the pointer inside the object, and then selecting **Begin** and **End**. You do not have to enclose the object in a box. The box can also be drawn as a horizontal line, a vertical line, or a single point, as long as at least part of the box intersects the object you want to move.*

**BLOCK Drag**     **BLOCK Drag** moves objects while maintaining connectivity. When you use this command, wires and buses appear to stretch as you move the block of objects on the worksheet. This effect is aptly called “rubberbanding.” When you finally place the block of objects, the wires and buses are extended to maintain their original connectivity.

**BLOCK Drag** works the same as **BLOCK Move**.

To drag a bus, first turn on the **SET Drag Buses** option (see the **SET** command later in this chapter) to maintain bus connectivity.

**BLOCK Fixup**     Use **BLOCK Fixup** to “fix up” wires and buses, making them orthogonal (perpendicular to each other) by adding new wire or bus segments.

Select **BLOCK Fixup**. **Draft** displays the command line:

```
Pick Find Jump Zoom
```

Use **Pick** to select the wire or bus to make orthogonal. Place the pointer so it touches either end of the wire or bus you want to make orthogonal and select **Pick** to select it. **Draft** displays the command line:

```
Drop End Find Jump Zoom
```

Move the pointer to the new endpoint. The end of the wire or bus moves with the pointer. In addition, **Draft** adds a new wire or bus segment that extends from the original wire or bus position to the new position.

Select **Drop** to “drop” a new wire or bus segment when you have it where you want it. You can continue dropping segments by selecting **Drop** as many times as desired.

Select **End** to drop the last segments when you have finished fixing up the wire or bus. **Draft** displays the **BLOCK Fixup** command line, so you can “fix up” another wire or bus. Press <Esc> to return to the main menu level.

△ **NOTE:** Use **BLOCK Fixup** only for adding segments when straightening non-orthogonal wires and buses. Use **BLOCK Drag** for cleanups that do not need additional segments.

*Multiple wires or buses*

If a node has more than one wire or bus connected, a menu displays that you use to select either **Drag All** or **Pick One** wire or bus.

Select **Drag All** to drag all the wires or buses attached to a common point.

Select **Pick One** to choose one wire or bus from those connected to the node. **Draft** displays the menu shown at right.

Pick One

Next

Previous

This

The wire or bus currently selected with **Pick One** is highlighted in another color. Select **Next** or **Previous** to select one of the other wires or buses. When the desired wire or bus is selected, select **This** to begin the “fix up.”

**BLOCK Get**

**BLOCK Get** retrieves objects saved in a buffer (using **BLOCK Save**, described later) and places them on the worksheet.

Select **BLOCK Get**. **Draft** displays:

Place Find Jump Zoom

A box containing the previously saved objects displays. The pointer is attached to this box. Move the box to the desired location. Place the objects on the worksheet by selecting **Place**.

The box containing the objects remains on the screen. You can place as many copies of the objects as desired. Simply move the box and select **Place**.

**BLOCK Save**      **BLOCK Save** stores a copy of a group of objects in a buffer so that they can be duplicated in another area of the worksheet.

Select **BLOCK Save**. Draft prompts:

```
Begin Find Jump Zoom
```

To select the objects to be saved, draw a box around them. Place the pointer where you want the corner of the box to start and select **Begin**. The command line changes to:

```
End Find Jump Zoom
```

Notice that the **Begin** command has changed to **End**.

Move the pointer. As you do this, **Draft** draws a box enclosing objects on the worksheet. When the box encloses all of the objects to save, select **End**. **Draft** saves a copy of the objects within the box in a buffer and returns to the main menu level.

Saved objects are placed on the worksheet using **BLOCK Get** (described previously).

△ ***NOTE:** The buffer used to save objects is also used by **BLOCK Move** and **BLOCK Drag**. Objects saved with **BLOCK Save** are lost after using either **BLOCK Move** or **BLOCK Drag**.*

*To save objects and still use **BLOCK Move** or **BLOCK Drag** in your editing session, use **BLOCK Export** rather than **BLOCK Save** to store worksheet objects.*

**BLOCK Import**    **BLOCK Import** retrieves objects stored in other files (with **BLOCK Export**, described below) and places them in your current worksheet.

Select **BLOCK Import**. Draft displays:

File to Import?

Enter the path and filename of the file to import.

△ *NOTE: If a pathname is entered in the Worksheet Prefix entry box on the Configure Schematic Design Tools screen, Draft uses that pathname. If you do enter a pathname here, Draft ignores the pathname specified on the Configure Schematic Design Tools screen.*

Draft displays:

Place Find Jump Zoom

Position the pointer on the worksheet where you want to place the contents of the file. Select **Place** to put the contents of the imported file on the worksheet. **Draft** places the imported objects on the worksheet. The pointer is in the same position as it was when the block of objects was exported with **BLOCK Export**. **Draft** returns to the main menu level.



**BLOCK Export**     **BLOCK Export** saves a copy of a group of objects in a file.

Select **BLOCK Export. Draft** displays:

Begin Find Jump Zoom

To select the objects to be saved, draw a box around them. Place the pointer where you want the corner of the box to start and select **Begin**. The starting corner is also the starting corner of the block when it is imported with **BLOCK Import**.

**Draft** displays:

End Find Jump Zoom

Notice that the **Begin** command has changed to **End**.

Move the pointer. As you do this, **Draft** draws a box. When the box encloses all of the objects you wish to save, select **End**. **Draft** displays:

Export filename?

Enter the path and filename to which to export the objects.

△ ***NOTE:** If a pathname is entered in the **Worksheet Prefix** entry box on the **Configure Schematic Design Tools** screen, **Draft** uses that pathname unless you enter one here. When you enter a pathname here, **Draft** ignores the pathname specified on the **Configure Schematic Design Tools** screen.*

**Draft** saves a copy of the objects enclosed and intersected by the box in this file and returns to the main menu level. The objects in this file can be placed back on the worksheet using **BLOCK Import** (described on the previous page).

**BLOCK ASCII  
Import**

**BLOCK ASCII Import** retrieves text stored in a text file and places it on your worksheet. You can create the text file with any editor that can read and write text.

Select **BLOCK ASCII Import**. **Draft** displays:

ASCII File to Import?

Enter the path and filename of the file to import. **Draft** displays the command line:

Place Find Jump Zoom

Position the pointer on the worksheet where you want to place the text. Select **Place**. The text file's contents are placed on the worksheet just to the right of the pointer. Each new line is placed below the previous line.

**Draft** returns to the main menu level.

△ ***NOTE:** If your text editor supports special formatting and layout of documents, you should make sure these special features are not used to create the text file.*

## BLOCK Text Export

**BLOCK Text Export** saves a copy of selected text in a text file. You can then edit this file with any editor that can read and write ASCII text. When you finish editing the text, you can place the contents of the text file back on the worksheet with the **BLOCK ASCII Import** command (described earlier).

Select **BLOCK Text Export**. **Draft** displays:

Begin Find Jump Zoom

To define the text to export, draw a box around it. Place the pointer where you want the corner of the box to start and select **Begin**. **Draft** displays:

End Find Jump Zoom

Notice that the **Begin** command has changed to **End**. Move the pointer. As you do this, **Draft** draws a box enclosing the text. When the box encloses all of the text you wish to export, select **End**. **Draft** displays:

Text Export Filename?

Enter the path and filename in which to export the text. A copy of the text enclosed and intersected by the box is saved in this file.

**Draft** returns to the main menu level.

△ **NOTE:** Only text objects can be exported. Labels or other characters associated with other objects cannot be exported.

## CONDITIONS

**CONDITIONS** monitors your computer's memory, and the memory available for the worksheet, hierarchy buffer, and macro buffer. When you select **CONDITIONS**, a status window displays (figure 2-2). The **CONDITIONS** status window does *not* respond to mouse commands. Press any key to return to the main menu level.

You can print a copy of the **CONDITIONS** status window by pressing <Print Screen>. Make sure the **Disable <Print Screen> key function** option on **Draft's** local configuration screen is not selected.

```

Press Enter to continue ■
CONDITIONS:

```

|                       | Location | Allocated | Used   | Available |
|-----------------------|----------|-----------|--------|-----------|
| Worksheet Memory Size | Main     | -----     | 365    | 163360    |
| Hierarchy Buffer      | Main     | 1024      | 0      | 1024      |
| Macro Buffer          | Main     | 8192      | 128    | 8064      |
| Active Library        | Main     | 157124    | 55124  | 102000    |
| Reference Library     |          |           |        |           |
| Name Table            | Main     | 65536     | 32000  | 33536     |
| Symbol Information    | EMS      | 320000    | 256000 | 64000     |

Figure 2-2. **CONDITIONS** status window.

For each of the items listed, **Draft** displays the location (main memory, EMS memory, or on disk), and the amount of memory—in bytes—allocated, used, and still available. The amount of memory allocated to any given item is specified on the **Configure Schematic Design Tools** screen. See *Chapter 1: Configure Schematic Design Tools* for information on how to configure these items.

### Worksheet Memory Size

This shows how much memory your worksheet uses and how much memory is available in your system. Blank worksheets use memory for border and title block information.

- Hierarchy Buffer** This shows the status of the hierarchy buffer. **Draft** uses the hierarchy buffer to keep track of sheet names when managing a hierarchical design. If the hierarchical design becomes too deep for the buffer, **Draft** is unable to keep track of all sheets in the hierarchy. You set the hierarchy buffer size when you configure **Schematic Design Tools**. For details, see *Chapter 1: Configure Schematic Tools*. For most applications, it is not necessary to change the size of the hierarchy buffer.
- Macro Buffer** This shows the status of the macro buffer. **Draft** stores macros (whether created on line or loaded from a macro file) in the macro buffer. If your macros are too large, the macro buffer is unable to store them. You set the macro buffer size when you configure **Schematic Design Tools**. For details, see *Chapter 1: Configure Schematic Tools*.
- Active Library** This shows the status of the active library. The active library is the temporary library **Draft** creates to hold both the name table and the symbol information for each part on the worksheet. **Draft** uses one active library.
- Draft** builds this library by copying information from the other libraries as a schematic is loaded or when you get a new part using **Draft's** **GET** command, and discards it when you exit **Draft**.
- Reference Library** This shows the status of the on-line library. The on-line library is split into two parts: the **Name Table** and the **Symbol Table**. These parts contain information about each part in every library configured to load with **Draft**.
- The **Name Table** contains a list of the parts in each library. The **Symbol Table** contains all of the symbol information for each part in each library.
- The symbolic data for on-line libraries can be placed in EMS memory or kept on disk. One advantage of using EMS memory is that **GET** and **LIBRARY Browse** commands are faster in **Draft**. A disadvantage is that you must have or install EMS memory.

**DELETE**

**DELETE** and its commands erase objects or blocks of objects. Use the **Undo** command in case you accidentally delete an object and would like to restore it to its original position.

Delete

Object

Block

Undo

When you select **DELETE**, the menu shown above displays. Each of the commands on this menu are described on the following pages.

**DELETE Object**

**DELETE Object** erases an object from the worksheet.

Select **DELETE Object**. **Draft** displays:

Delete Find Jump Zoom

To delete an object, place the pointer on the object you want to delete and select **Delete**.

△ ***NOTE:** You must place the pointer on or within the body of a part to delete it.*

If you want to delete one of two intersecting wires and you have placed the pointer at their intersection, the first wire drawn is the first deleted. To delete the last wire drawn, move the pointer away from the intersection along the wire to delete and select **Delete**.

If the pointer is pointing to more than one type of object, **Draft** displays:

Delete which Object?

**Draft** displays a menu listing objects to delete. Select the object from the menu to delete it.

After deleting an object from the worksheet, **Draft** returns to the **DELETE Object** command line, where you may continue to delete objects.

To return to the main menu level and redraw the worksheet, press <Esc>.

**DELETE Block**     **DELETE Block** deletes a block of objects on a worksheet.

Select **DELETE Block**. **Draft** prompts:

Begin Find Jump Zoom

To select the objects to delete, draw a box around them. Place the pointer where you want the corner of the box to start and select **Begin**. The command line changes to:

End Find Jump Zoom

Notice that the **Begin** command has changed to **End**.

Move the pointer. As you do this, **Draft** draws a box enclosing objects on the worksheet. When the box encloses or intersects all of the objects you wish to delete, select **End**. **Draft** deletes objects within or intersected by the box. After deleting the block of objects, **Draft** returns to the main menu level.

**DELETE Undo**     **DELETE Undo** restores your last deletion by restoring an accidentally deleted object or block of objects.

Select **DELETE Undo**. The object(s) deleted with the last **DELETE Object** or **DELETE Block** command is restored.

---

**EDIT**

Use **EDIT** to:

- ❖ Edit labels, text, module ports, power objects, sheets, part reference designators, part values, part fields, and the title block.
- ❖ Change pin names and numbers on devices with multiple parts-per-package.
- ❖ Move part reference designators, part values, and part fields to new locations on the worksheet.
- ❖ Make part reference designators, part values, or part fields visible or invisible.
- ❖ Change the style of parts, power objects, module ports, labels, and text.
- ❖ Change the orientation of parts, text, and labels.
- ❖ Change the size of text and labels.
- ❖ Edit sheets, sheet names, sheet nets, sheet net types, and sheet filenames. You can use **EDIT** to add sheet nets or to delete sheet nets.

Select **EDIT**. **Draft** displays:

|                     |
|---------------------|
| Edit Find Jump Zoom |
|---------------------|

To edit an object, place the pointer on the object you want to edit and select **Edit**. The menu that displays depends on what you are editing. These menus are described on the following pages.

### Editing techniques

When editing text fields, use these techniques:

- ❖ Position the cursor with the <←> and <→> keys, or the <Home> and <End> keys, or the mouse
- ❖ Erase characters with <Backspace> or <Delete>
- ❖ Add new characters with the alphanumeric keys



**Editing labels**

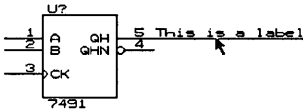

To edit a label, place the pointer immediately below and within the label, as shown in the figure at the left. Select **Edit. Draft** displays the menu shown at right.

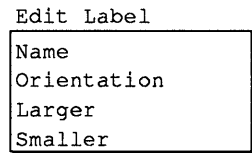

*Name*

Select **Name** to edit the name of a label. After selecting **Name**, the prompt "Name?" displays followed by the current label name.

Edit the name using the editing techniques described at the beginning of the **EDIT** section. When you finish, press <Enter>. The edited name displays on the worksheet.

*Orientation*

Select **Orientation** to specify the label's orientation. Select the desired orientation: **Horizontal** or **Vertical**.

*Larger*

Select **Larger** to make the label's character size larger. You may select **Larger** more than once until the text is as large as you desire.

*Smaller*

Select **Smaller** to make the label's character size smaller. As with **Larger**, you may select **Smaller** multiple times.

## Editing module ports

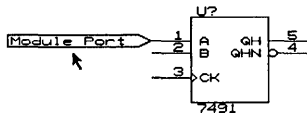

To edit a module port, place the pointer within the module port symbol and select **Edit**. **Draft** displays the menu shown at right.

### Edit Module Port

|       |
|-------|
| Name  |
| Type  |
| Style |

*Name* Select **Name** to edit a module port name. **Draft** displays the prompt “Module Port Name?” followed by the current module port name.

Edit the module port name using the editing techniques described at the beginning of the **EDIT** section. When you finish editing, press <Enter>. The module port name displays on the worksheet.

*Type* Select **Type** to change the type of module port (figure 2-3). Select the type of module port: **Input**, **Output**, **Bidirectional**, or **Unspecified**.

*Style* Select **Style** to change how the module port looks (figure 2-3). Choose from: **Right pointing**, **Left pointing**, **Both pointing**, or **Neither pointing**.

Figure 2-3 shows the different types of module ports and their default styles. A module port’s style is independent from its type. For example, a “both pointing” style does not mean that the module port is bidirectional.

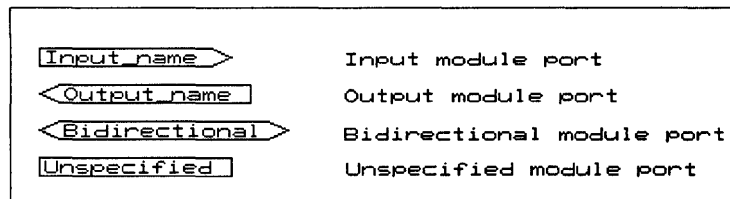
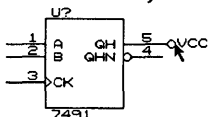

Figure 2-3. Types of module ports and their default styles.

### Editing power objects



A power object is a schematic symbol that represents some type of power supply connected to the design.

Edit Power

- |             |
|-------------|
| Name        |
| Type        |
| Orientation |

To edit a power object, place the pointer on a power object and select **Edit**. **Draft** displays the menu shown above.

**Name** Select **Name** to edit the name of the power object. **Draft** displays the prompt "Power Name?" followed by the object's current name.

Edit the name using the editing techniques described at the beginning of the **EDIT** section. When you finish, press <Enter>. The name displays on the worksheet.

**Type** Select **Type** to change the type of power object. The different types (shown in the figure at the right) are **Circle**, **Arrow**, **Bar**, or **Wave**.

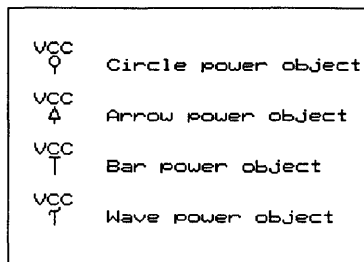

**Orientation;** Select **Orientation** to change the orientation to **Top**, **Bottom**, **Left**, or **Right**.

## Editing sheet symbols

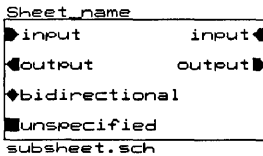

Sheet symbols are used in hierarchical designs to represent references to other schematic worksheets.

To edit sheet symbols, place the pointer within a sheet symbol boundary and select **Edit**. Draft displays:

Add-Net Delete Edit Name Filename Size Zoom

After you select **Edit**, pointer movement is restricted to the border of the sheet symbol. This helps you place the pointer at sheet net name locations.

### Add-Net

Select **Add-Net** to add net connections between worksheets. To add a net connection to a sheet symbol, move the pointer to an appropriate position and select **Add-Net**.

Draft displays the prompt "Net Name?" Enter the desired net name. A menu displays listing the types of net symbols: **Input**, **Output**, **Bidirectional**, and **Unspecified**. Figure 2-4 shows the types of net symbols. Select the appropriate type.

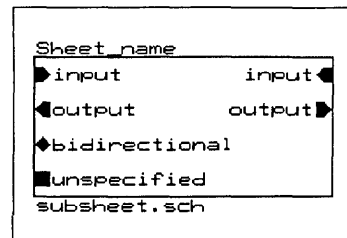

Figure 2-4. Net symbol types.

Notice the input net symbol points into the sheet symbol, and the output net symbol points out of the sheet symbol.

### Delete

To delete a net name, place the pointer on the net name and select **Delete**.

*Edit* To edit a net's name or type, put the pointer on the net name and select **Edit**. The menu shown at right displays.

|          |
|----------|
| Edit Net |
| Name     |
| Type     |

- ❖ Select **Name** to change the name of the net. The net name displays on the prompt line. Edit it using the editing techniques described at the beginning of the **EDIT** section. When you finish, press <Enter>.
- ❖ Select **Type** to change the type of the net. A menu displays listing the types of net symbols: **Input**, **Output**, **Bidirectional**, and **Unspecified**. Figure 2-4 shows each of these types of net symbols. Select the appropriate type.

*Name* Use **Name** to edit the name of a sheet symbol, located at the top of the sheet. Initially, the sheet name is a question mark. Typically, names identify the function of the worksheet represented by the sheet symbol (such as "Memory Array" or "Dynamic RAM Refresh Circuitry").

To edit the sheet symbol's name, select **Name**. **Draft** displays "Sheet name?" and shows the current name.

Edit the name using the editing techniques described at the beginning of the **EDIT** section. When you finish editing the name of the sheet symbol, press <Enter>.

Press <Esc> to cancel any changes to the sheet name.

*Filename* Use **Filename** to edit the name of the worksheet represented by a sheet symbol.

**Draft** automatically creates a filename based on the date and time of day, ensuring no two filenames will be alike. This name displays at the bottom of the sheet symbol as soon as it is created.

To edit the filename, select **Filename**. **Draft** displays the prompt "Filename?" followed by the current filename.

Edit the filename using the editing techniques described at the beginning of the **EDIT** section. When you finish editing the filename, press <Enter>.

*Size*    Select **Size** to change the size of the sheet symbol displayed on the screen. **Draft** displays:

|                     |
|---------------------|
| End    Jump    Zoom |
|---------------------|

**Draft** moves the pointer to the lower right corner of the sheet symbol. To change its size, move the pointer until the symbol's size is satisfactory, then select **End**.

**Editing parts**

Use **Edit Part** to:

- ❖ Edit and move part reference designators, values, and fields
- ❖ Select other parts in library parts with multiple parts per package
- ❖ Change the orientation of the symbol.

Figure 2-5 illustrates a library part with its default reference designator and part value.

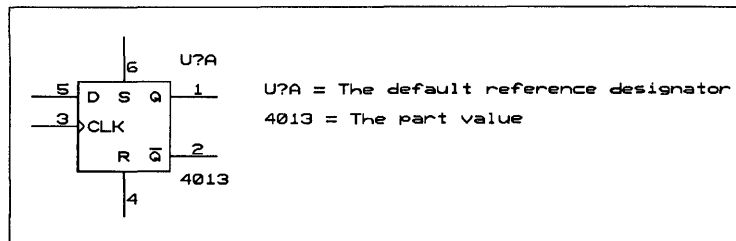

Figure 2-5. CMOS 4013 library part.

To edit a part, place the pointer within the part symbol boundary and select **Edit**. For a description of a symbol boundary, see *The outline symbol* under the **GET** command description in this chapter.

When you select **Edit**, **Draft** displays the menu shown at right.

**Which Device** only displays when you edit a device with multiple parts per package.

- |                |
|----------------|
| Edit Part      |
| Reference      |
| Part Value     |
| 1st Part Field |
| 2nd Part Field |
| 3rd Part Field |
| 4th Part Field |
| 5th Part Field |
| 6th Part Field |
| 7th Part Field |
| 8th Part Field |
| Orientation    |
| Which Device   |

*Reference*

Select **Reference** to edit or move the reference designator values of library parts placed on the worksheet. **Draft** displays the menu shown at right.

- |           |
|-----------|
| Reference |
| Name      |
| Location  |
| Visible   |

Examples of reference designators are: U1, U2A, Q6, R1, R2, and C12.

See *Chapter 6: Annotate Schematic* for a method of automatically incrementing reference designators and changing the corresponding pin numbers of parts placed on the worksheet.

### *Name*

Select **Name** to edit the name of a reference designator. The prompt "Reference?" displays. If the part already has a reference designator name assigned, it also displays on the prompt line.

Edit the name using the editing techniques described at the beginning of the **EDIT** section. When you finish editing the name, press <Enter>.

△ *NOTE: Some library parts contain more than one part per package. For example, a 74LS04 hex inverter contains six parts. The reference designators for the six parts may be U?A, U?B, U?C, U?D, U?E, and U?F. The last letter in the reference designator tells which one of the parts in the package you are editing. You cannot edit this last letter with the **EDIT Edit Name** command. To edit a different part in a multiple-part package, use the **EDIT Edit Which Device** command.*

### *Location*

Select **Location** to change the reference designator's location. **Draft** highlights the part's reference designator, value, and part fields, and displays the menu shown at right.

|       |
|-------|
| Place |
| Find  |
| Jump  |
| Zoom  |

You may move the reference designator anywhere in the worksheet using the arrow keys or the mouse. Select **Place** to place the reference designator at the new location.



*Visible*

Select **Visible** to choose whether the reference designator appears on the screen and on paper prints and plots. When you select **Visible**, a menu displays **Yes** and **No**. **Yes** makes the reference designator visible; **No** makes it invisible. The **Visible** command controls the visibility of reference designators at all zoom scales.

*Part Value*

Select **Part Value** to edit or move the part values of components on the worksheet. Examples of part values are: 100K, 1N4004, .01 uf, 2N2222, and 80386.

Value

|          |
|----------|
| Name     |
| Location |
| Visible  |

When you select **Part Value**, **Draft** displays the menu shown above.

*Name*

Select **Name** to edit a part value. The prompt "Value?" displays. If the part already has a value assigned, it also displays on the prompt line.

Edit the value using the editing techniques described at the beginning of the **EDIT** section. When you finish editing the part value, press <Enter>.

*Location*

Select **Location** to change the part value's location. **Draft** highlights the part's reference designator, value, and part fields and displays the menu shown at right.

|       |
|-------|
| Place |
| Find  |
| Jump  |
| Zoom  |

You may move the part value anywhere in the worksheet using the arrow keys or mouse. Select **Place** to place the part value in the new worksheet location.

### Visible

Use **Visible** to choose whether the part value appears on the screen and on paper prints and plots. When you select **Visible**, **Draft** a menu displays **Yes** and **No**. **Yes** makes the part value visible; **No** makes it invisible. **Visible** controls the visibility of part values at all zoom scales.

### 1st Part Field through 8th Part Field

Eight part fields may be placed on the schematic worksheet by selecting them from the menu. Use **1st Part Field** through **8th Part Field** to add information about the part (such as tolerance, part number, vendor information, and so on) to the schematic. When you select one of the eight part fields, **Draft** displays the menu shown above.

| 1st Part Field |
|----------------|
| Name           |
| Location       |
| Visible        |

### Name

Select **Name** to edit the information in a part field. The prompt "xx Part Field?" displays. If the part field already contains information, it also displays here.

Edit the information using the editing techniques described at the beginning of the **EDIT** section. When you finish editing the part field, press <Enter>.

△ **NOTE:** If you changed the part field names on the **Configure Schematic Design Tools** screen, **Draft** displays their new names in menus and prompts.

### Location

Select **Location** to change the location of the part field on the worksheet. **Draft** highlights the part's reference designator, value, and part fields and displays the menu shown at right. Use the arrow keys or the mouse to move the part field anywhere on the worksheet. Select **Place** to place the part field in the new location.

|       |
|-------|
| Place |
| Find  |
| Jump  |
| Zoom  |

### *Visible*

Select **Visible** to choose whether the part field appears on the screen and on paper prints and plots. When you select **Visible**, a menu displays **Yes** and **No**. **Yes** makes the part field visible; **No** makes it invisible. **Visible** controls the visibility of part fields at all zoom scales.

### *Orientation*

Select **Orientation** to change the view of a part. **Draft** displays the following command line:

```
Rotate Convert Normal Up Over Down Mirror Zoom
```

### *Rotate*

**Rotate** turns the part 90° counterclockwise from its current position.

### *Convert*

Use **Convert** to change the form of the part.

**Convert** only displays when editing a part that contains its normal representation as well as a DeMorgan form. Parts with DeMorgan form actually have two versions of the part in the library. For example, the 74LS02 contains its standard form (a NOR) gate and a DeMorgan form (an inverted AND gate).

See *Chapter 17: Edit Library* for an explanation of how a part is given a DeMorgan form.

### *Normal*

**Normal** returns a rotated part to its original orientation, as created in the part library. **Normal** also cancels the effect of the **Convert** and **Mirror** commands.

### *Up*

**Up** rotates a part 90° counterclockwise from its normal position, equivalent to rotating it once from its normal position.

*Over*

**Over** rotates a part 180° counterclockwise, equivalent to rotating it twice from its normal position.

*Down*

**Down** rotates a part 270° counterclockwise, the equivalent of rotating it three times from its normal position.

*Mirror*

**Mirror** displays a mirror-image of a part. Mirroring is along the horizontal axis.

*Which Device*

**Which Device** only displays when you edit a part containing more than one part per package. An example would be a 74LS04 hex inverter, which contains six inverters. To select a different part in the package, select **Which Device** and then select the device letter of the part to edit.

**Editing the title block**

To edit title block information, place the pointer inside the title block and select **Edit**. The title block is in the lower right worksheet corner. **Draft** displays the menu shown at right.

If a field is empty, simply enter the appropriate information. If the field already contains information, edit the information using the editing techniques described at the beginning of the **EDIT** section.

Edit title block

- Revision code
- Title of sheet
- Document number
- Sheet number
- Number of sheets
- Organization name
- 1st Address Line
- 2nd Address Line
- 3rd Address Line
- 4th Address Line

|   |                 |              |
|---|-----------------|--------------|
| OrCAD   |                 |              |
| 3175 N.W. Alciek Drive<br>Hillsboro, Oregon 97124<br>(503) 690-9881 |                 |              |
| Title<br>Demonstration Worksheet                                    |                 |              |
| Size  | Document Number | REV          |
| A   | 191-0005        | A            |
| Date: November 12, 1990   |                 | Sheet 1 of 1 |

*Revision Code*

Select **Revision Code** to add or edit the revision code (three characters maximum). **Draft** displays the prompt "Revision Code?"

*Title of Sheet*

Select **Title of Sheet** to add or edit a title (44 characters maximum). **Draft** displays the prompt "Title of Sheet?"

*Document Number*

Select **Document Number** to edit or add a document number (36 characters maximum). **Draft** displays the prompt "Document Number?"

*Sheet Number*

Select **Sheet Number** to add or edit a sheet number (any number up to 32767). **Draft** displays "Sheet Number?"

*Number of Sheets*      Select **Number of Sheets** to add to the number of worksheets (any number up to 32767). **Draft** displays the prompt "Number of Sheets?"

*Organization Name*      Select **Organization Name** to add or edit an organization name (up to 44 characters). **Draft** displays the prompt "Organization Name?"

*Address Lines*      Select the address line to edit. Each line can be up to 44 characters long. **Draft** displays the prompt "*xxx* Address Line?", where *xxx* is either 1st, 2nd, 3rd, or 4th, depending on the address line you are editing.



**NOTE:** See the **PLACE** command description in this chapter for a definition of the syntax format of the objects described on this page.

**Editing stimulus objects**



To edit a stimulus object, place the pointer at the location where the stimulus object connects to the wire or pin on which it was placed. Select **Edit**. The prompt "Stimulus?" displays followed by the current value.

Edit the value using the editing techniques described at the beginning of the **EDIT** section. When you finish editing, press <Enter>.

**Editing trace objects**



To edit a trace object, place the pointer at the location where the trace object connects to the wire or pin on which it was placed. Select **Edit**. The prompt "Trace Name?" displays followed by the current name.

Edit the name using the editing techniques described at the beginning of the **EDIT** section. When you finish editing, press <Enter>.

**Editing vector objects**



To edit a vector column, place the pointer at the location where the vector object connects to the wire or pin on which it was placed. Select **Edit**. The prompt "Vector Column?" displays followed by the current value.

Edit the vector column using the editing techniques described at the beginning of the **EDIT** section. When you finish editing, press <Enter>.

**Editing layout objects**



To edit a layout directive, place the pointer where the layout symbol connects to the wire or pin on which it was placed. Select **Edit**. The prompt "Layout Directive?" displays followed by the current layout directive.

Edit the layout directive using the editing techniques described at the beginning of the **EDIT** section. When you finish editing, press <Enter>. The edited name displays on the worksheet.

---

**FIND**

**FIND** locates a string of text characters any-where in a worksheet and places the pointer at the object containing the search string. A search string can be any number of characters identifying any of the following items:

- ❖ Module ports
- ❖ Labels
- ❖ Reference designators
- ❖ Part values
- ❖ Data stored in a part field
- ❖ Sheet symbol names
- ❖ Power objects
- ❖ Text

You must specify a complete character string. For example, if the part value "74LS00" exists in the worksheet and you specify "LS" as the search string, **Draft** returns the message "<<<Not Found>>> LS". However, if you specify the complete string "74LS00", **Draft** places the pointer at the object containing the string.

Select **FIND**. **Draft** displays "Find?" Enter the character string you want to find. The character string can be entered in upper or lower case; **FIND** is not case sensitive. **Draft** searches the worksheet for the desired character string and places the pointer near it.

The next time you select **FIND**, **Draft** shows the previous string on the prompt line. To search for a new string, edit the previous entry by positioning the cursor with the <←> and <→> keys and the <Home> and <End> keys, erasing characters with <Backspace> or <Delete>, and adding new characters with the alphanumeric keys. When you finish entering the new string, press <Enter>.

If you are searching for a string identical to the last string (for example, you want to find all 200 Ω resistors on the worksheet), press <Enter> with the current string name on the prompt line. **Draft** remembers the location of the previous string and searches for the next one.



If you select **FIND** after finding the last occurrence of the string, **Draft** “wraps” to the first occurrence of the string. If there is only one occurrence of the string, **FIND** returns repeatedly to the string when the command is selected.

△ ***NOTE:** FIND works only in the worksheet you are editing.*

△ ***NOTE:** To erase the previous string, select **FIND** and press <Esc>. When **FIND** is selected again, the field is cleared.*

**GET**

GET retrieves parts from the library database and places them in the worksheet as normal, rotated, or converted symbols. There are two methods you can use with GET to retrieve parts.

| <i>Method 1</i>  | <i>Method 2</i>  |
|--|--|
| <p>Select <b>GET</b>. <b>Draft</b> displays "<b>Get ?</b>"</p> <p>Enter the desired part name <i>exactly</i> as it appears in the library directory. <b>Draft</b> searches the libraries you specified when you configured <b>Schematic Design Tools</b> and finds the part you requested. Once it finds the part, <b>Draft</b> puts its outline on the screen.</p> <p>If there are two parts with the same name in the configured libraries, <b>GET</b> <i>always</i> retrieves the first one. If the name typed does not match any part name in the library directory, <b>Draft</b> shows an error message. To verify the spelling of a part name, use the <b>LIBRARY Directory</b> command.</p> | <p>Select <b>GET</b>. <b>Draft</b> displays "<b>Get ?</b>"</p> <p>Press &lt;Enter&gt;. <b>Draft</b> displays a list of libraries. These are the libraries you specified when you configured SDT. Select the library you want to get a part from.</p> <p>After you select a library, <b>Draft</b> displays a menu listing the library parts. Move the highlight to the part name you want, then press &lt;Enter&gt; to retrieve the part. <b>Draft</b> puts the part's outline on the screen.</p> |

Once the part outline displays, you need to place it on the worksheet. For information on rotating and placing parts on the worksheet, see *Rotating and placing parts* in this section.

### Getting a part by entering a part suffix

If you are using Method 1 (described on the previous page), you can select library part numbers created with a prefix and shorthand string (see *Prefix definition* in *Chapter 14: About libraries*) from the library by entering the suffix. For example, suppose you want to retrieve a 74LS27 from the library. After selecting **GET**, enter any of the following examples to retrieve the part:

- Get? 74LS27    In this example, the entire part name is used to retrieve the part.
- Get? LS27      In this example, the prefix "LS" (which is the shorthand string for "74LS") is combined with the suffix "27." **Draft** retrieves the part 74LS27.
- Get? 27        In this example, only the suffix "27" is entered. **Draft** looks through all of the configured libraries and displays a menu of all available parts with "27" as a suffix. Select the desired part from the menu.

### The outline symbol

After getting the part from the library, the screen shows an outline of the part symbol (figure 2-6). The outline symbol shows the size and shape of the part, but no detail. Its function is to let **Draft** move the part quickly around the worksheet.

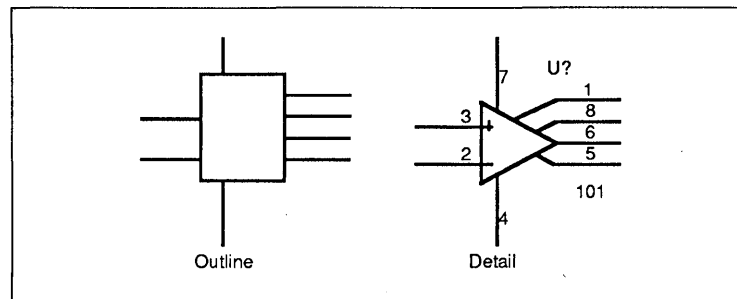

Figure 2-6. A part's outline symbol and its detailed symbol.

If the outline symbol remains stationary for a short time, **Draft** shows the detailed part symbol enclosed by the outline symbol. Use this feature to view the position the part will have when it is placed in the worksheet.

**Rotating and placing parts**

With the part selected and the outline symbol displayed, **Draft** displays this command line:

```
Place Rotate Convert Normal Up Over Down Mirror
```

Move the symbol to where you want to place it. Use these commands to rotate or place the part in the worksheet.

*Place* Select **Place** to place the part on the worksheet.

After you place a part on the worksheet, **Draft** keeps the same part selected, so that you can repetitively place duplicates of a part without repeating the selection process. When you have placed all the parts, press <Esc> to return to the main command level.

When an outline symbol is placed over a copy of the same object already placed on the worksheet, the object may disappear. Moving the outline symbol displays the placed part.

*Rotate* Select **Rotate** to turn a part counterclockwise 90° (figure 2-7). Each time you select **Rotate**, the part rotates an additional 90°.

*Convert* Some library parts have a second form, usually (but not always) a DeMorgan equivalent, as well as the standard representation. If an object has a converted form, the **Convert** command displays on the command line when it is retrieved from the library.

Select **Convert** to convert the object from its normal form to its converted form. You may see the converted object by leaving the outline symbol stationary.

To return a converted object to its original form, select **Normal**.

*Normal* Select **Normal** to rotate an object to its original position, as shown in the library (figure 2-7). This command also returns mirrored or converted parts to their original form.

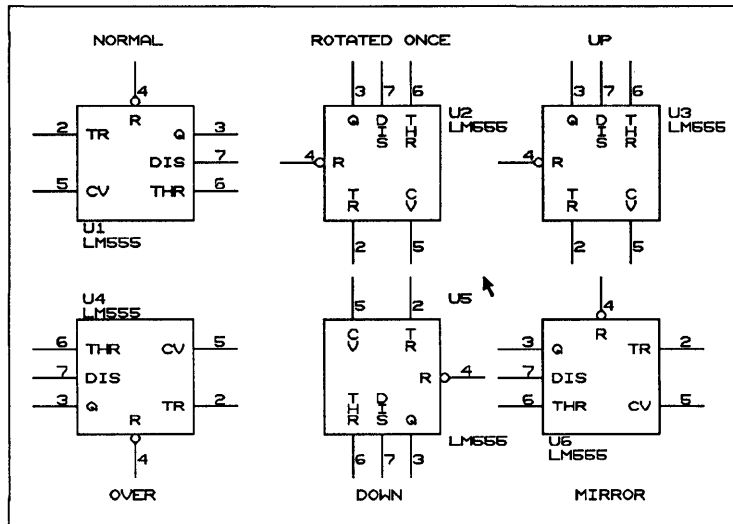

Figure 2-7. Normal, Rotated, Up, Over, Down, and Mirrored positions.

**Up** Select **Up** to turn an object 90° counterclockwise (figure 2-7). This is equivalent to rotating it once from its normal position.

**Over** Select **Over** to turn an object 180° counterclockwise (figure 2-7). This is equivalent to rotating it twice from its normal position.

**Down** Select **Down** to turn an object 270° counterclockwise (figure 2-7). This is equivalent to rotating it three times from its normal position.

**Mirror** Select **Mirror** to get a mirror image of an object (figure 2-7).

---

## HARDCOPY

**HARDCOPY** uses fast draft printing mode to send a worksheet to the printer or to a file. **HARDCOPY** does not produce scaled or compressed output.

**HARDCOPY** is not used to output to plotters. To plot a schematic, use the **Plot Schematic** reporter described in *Chapter 25: Plot Schematic*. To print a schematic in scaled mode, use the **Use Scale Factor** option, as described in the *Local Configuration* section of *Chapter 19: Plot Schematic*.

To make a fast draft print, **HARDCOPY** assumes a working resolution of 100 units per inch. Therefore, if you are using a printer with 100 dpi (dots per inch) resolution, your **HARDCOPY** print is at full scale.

For example, there are four Hewlett-Packard LaserJet printer resolutions available with **Schematic Design Tools** (75, 100, 150, and 300 dpi). If your printer's resolution is 300 dpi, your print will be 100:300, or  $\frac{1}{3}$  the actual size. Similarly, if you are using a Toshiba printer with a resolution of 180 dpi, your print will be 100:180, or  $\frac{5}{9}$  the actual size.

To print a schematic, select **HARDCOPY** from the main menu.

**Draft** displays the menu shown at right.

|                |
|----------------|
| Hardcopy       |
| Destination    |
| File Mode      |
| Make Hardcopy  |
| Width of Paper |

- △ **NOTES:** *Some versions of DOS and BIOS do not support ports COM3: and COM4: . If your printer is connected to one of these serial ports and **HARDCOPY** does not print, try changing to a different serial port or to a parallel port.*

*For printing the entire design, use the **Print Schematic** reporter (described in *Chapter 20: Print Schematic*) or **Plot Schematic** reporter (described in *Chapter 19: Plot Schematic*).*

*For most display drivers, you can also use the **Print Screen** (<Shift><Print Screen>) key to send the area of the worksheet displayed on the screen to the printer.*

**HARDCOPY  
Destination**

You can send a worksheet either to a printer or to a file. This command selects the hardcopy destination.

Destination

|      |
|------|
| LPT: |
| File |

Select **Destination**. **Draft** displays the menu shown above.

*LPT:* Select **LPT:** to send your worksheet to the printer port specified on the **Configure Schematic Design Tools** screen.

*File* Select **File** to send the worksheet to a file. **Draft** displays the prompt "Destination of Hardcopy?" followed by the default filename **HARDCOPY.PRN**.

Change the default filename using the editing techniques described at the beginning of the **EDIT** section. When you finish editing, press <Enter>.

You can specify a complete pathname including a drive specification. Because the output file is a graphics file, it requires more disk space than the source schematic file.

To return to the main menu level, press <Esc>.

Files created this way can later be sent to the printer using the DOS **COPY** command. For example, if you created a printer file called **MY.PRN**, you can print it with the following DOS command:

|                                  |
|----------------------------------|
| <code>COPY MY.PRN prn: /B</code> |
|----------------------------------|

The **/B** parameter is needed because **MY.PRN** is a binary file. **/B** prevents **COPY** from terminating prematurely when it encounters the first Ctrl-Z character in the file.

△ **NOTE:** Because the hardcopy file is a binary file, the DOS **PRINT** command cannot be used. For more information on **COPY**, see your DOS Manual.

**HARDCOPY  
File Mode**

**File Mode** determines whether subsequent **HARDCOPY** commands append or replace the contents of any existing hardcopy file.

File Mode

|          |
|----------|
| Appended |
| Replaced |

Select **File Mode**. **Draft** displays the menu shown above.

*Appended*

Adds new data to the contents of the destination file. With this command, you can save a series of hardcopies to the same filename.

*Replaced*

Replaces the contents of the destination file with new data. This command overwrites the current contents of the destination file with the new hardcopy.

**HARDCOPY  
Make Hardcopy**

**Make Hardcopy** prints a hardcopy of the worksheet displayed on the screen. It either sends it to your printer or to a file, depending on the setting of **File Mode**.

To send a copy of your worksheet to your printer, first make sure your printer has power and is on line. Then select **Make Hardcopy**. **Draft** displays:

|                                  |
|----------------------------------|
| :::Creating Hardcopy of Sheet::: |
|----------------------------------|

After a few seconds, the worksheet starts printing.

**HARDCOPY  
Width of Paper**

Use **Width of Paper** to choose between narrow and wide paper.

Width of Paper

|        |
|--------|
| Narrow |
| Wide   |

Select **Width of Paper**. **Draft** displays the menu shown at right.

*Narrow*

Select **Narrow** if you have narrow paper (8 inches wide).

*Wide*

Select **Wide** if you have wide paper (13 inches wide).



## **INQUIRE**

**INQUIRE** displays text associated with stimulus, trace, vector, layout, and error objects. **Draft** associates text strings, some potentially lengthy, with these objects. **INQUIRE** keeps the schematic neat and uncluttered by making it possible to see and edit text information belonging to an object when needed.

Move the pointer to an object and select **INQUIRE**. The text associated with the object displays on the top line of the screen. Press <Enter> or <Esc> to return to the main menu level.

If the text is too large to fit across the top of your screen, scroll the text left and right using the <←> or <→> keys or the mouse.

If you repeat **INQUIRE** on a position in the schematic and there is more than one object located there, **Draft** cycles through the texts associated with each object.

## JUMP

**JUMP** quickly moves the pointer to specific locations on the worksheet. The specific locations can be tags, grid references, or X,Y coordinates.

Select **JUMP**. **Draft** displays the menu shown at right.

### Jump

|            |
|------------|
| A Tag      |
| B Tag      |
| C Tag      |
| D Tag      |
| E Tag      |
| F Tag      |
| G Tag      |
| H Tag      |
| Reference  |
| X-Location |
| Y-Location |

### JUMP A, B, C, D, E, F, G, H Tag

When you select one of the **JUMP Tag** commands, the pointer jumps to the specified tag on the worksheet (the tag must have been previously set with the **Tag** command). For information about the **Tag** command, see the *Tag* section in this chapter.



**NOTE:** The error message "Tag does not exist" displays if the tag you select has not been set.

### JUMP Reference

The **Reference** command moves the pointer to a specified grid reference on the worksheet border. Grid references are invisible until you set them using the **SET Grid Parameters** command. For information on grid parameters, see the *SET Grid Parameters* section of this chapter.

To jump to a grid reference, follow these steps:

- 1 Select **JUMP Reference**.
- 2 **Draft** displays "Jump to Reference". Select the desired Y-axis grid alphabetic reference from the menu. See table 2-1 for the range of letters that can be used as grid references.
3. Select the desired X-axis numeric grid reference from the menu. See table 2-1 for the range of numbers that can be used as grid references.

The pointer jumps to the grid reference location specified and **Draft** returns to the main menu level.

| Sheet Size | Ansi Reference |              | Common References |              |
|------------|----------------|--------------|-------------------|--------------|
|            | X Grid Range   | Y Grid Range | Y Grid Range      | X Grid Range |
| A          | N/A            | N/A          | A..D              | 1..8         |
| B          | N/A            | N/A          | A..D              | 1..8         |
| C          | A..D           | 1..4         | A..D              | 1..8         |
| D          | A..D           | 1..8         | A..D              | 1..8         |
| E          | A..H           | 1..8         | A..D              | 1..8         |

Table 2-1. X and Y grid references. N/A indicates that the value is not applicable because the sheet size does not have grid references per ANSI Y14.1-1980.

### JUMP X-Location

The X-Location command moves the pointer a specific distance along the X-axis. Each step represents  $\frac{1}{10}$  (0.1) inch on the worksheet if **SET Grid Parameters Stay On Grid** is turned on. Otherwise it is  $\frac{1}{100}$  (0.01) inch.

To jump to an X-location, follow these steps:

1. Select **JUMP X-Location**.
2. Draft displays "Jump X". Enter the number of steps to jump. A number without a plus or minus sign moves the pointer to the actual grid coordinate. A number with a positive sign (+10, +25, +30, and so on) moves the pointer to the right, and a number with a negative sign (-10, -25, -30, and so on) to the left. If you enter +10, for example, the pointer jumps to the right 1 inch from its current position (if you have **SET Grid Parameters Stay On Grid** turned on). If you enter 10, without a plus or minus sign, the pointer moves to the actual X grid coordinate 10.0.

When you press <Enter>, the pointer jumps to the specified location and **Draft** returns to the main menu level.

**JUMP Y-Location**    The **Y-Location** command moves the pointer a specific distance along the Y-axis. Each step represents  $\frac{1}{10}$  (0.1) inch on the worksheet if the **SET Grid Parameters Stay On Grid** command is turned on; otherwise it is  $\frac{1}{100}$  (0.01) inch.

The jump to a Y-location, follow these steps:

1. **Select Y-Location.**
2. **Draft** displays "Jump Y". Enter the number of steps to jump. A number without a plus or minus sign moves the pointer to the actual grid coordinate, a number with a positive sign (+10, +25, +30, and so on) moves the pointer up, and a number with a negative sign (-10, -25, -30, and so on) down. If you enter +10, for example, the pointer jumps up 1 inch from its current position (if you have **SET Grid Parameters Stay On Grid** turned on). If you enter 10, without a plus or minus sign, the pointer moves to the actual Y grid coordinate 10.0.

When you press <Enter>, the pointer jumps to the specified location and **Draft** returns to the main menu level.

## **LIBRARY**

**LIBRARY** displays part list directories of libraries and displays images of the parts in libraries configured to load with **Draft**.

Library  
Directory  
Browse

Select **LIBRARY**. **Draft** displays the menu shown above.

### **LIBRARY Directory**

Use the **LIBRARY Directory** command to select a library and list its contents. The list can be displayed, printed, or saved in a file.

Select **LIBRARY Directory**. **Draft** displays a menu similar to the one at right, listing the libraries currently configured in **Draft**. From this menu, select the library for which to view a directory.

Which Library?  
PCBDEV.LIB  
TTL.LIB  
DEVICE.LIB

**Draft** displays the menu shown at right.

To?  
Screen  
Printer  
File

*Screen* Select **Screen**. **Draft** displays the library directory on the screen.

*Printer* Select **Printer**. **Draft** prints the library directory on the printer connected to the printer port specified on the **Configure Schematic Design Tools** screen.

*File* Select **File**. **Draft** displays "File?" on the prompt line. Enter the path and filename. **Draft** sends the library directory to the file.

**LIBRARY Browse** Use the **Browse** command to view the contents of a library, or select a part and view it on the screen.

```
Browse
All Parts
Specific Parts
```

Select **Browse**. The menu shown above displays.

△ *NOTE: Some devices may be too large to fit entirely on the screen. Use the **GET** command to view these devices.*

*All Parts* Select **All Parts** to view all the parts in a library. **Draft** displays a menu showing a list of the libraries currently configured to load with **Draft**. Select the library you want to view. **Draft** displays the menu shown below.

Select **Forward** or **Backward** to browse through the library. Select **Quit** to return to the main menu level.

```
22V10 - Continue?
Forward
Backward
Quit
```

*Specific Parts* Select **Specific Parts** to view individual parts from the libraries. **Draft** displays "Part?"

Enter the name of the part you want to view. The part displays on the screen. If you do not know the name of the part, press <Enter> to display a list of parts. See *Chapter 17: Edit Library* for details.

## MACRO

Macros are recordings of commands that you create and play back to run commands quickly, reducing the number of keystrokes required to perform repetitive and complex tasks. Use the **MACRO** command to capture, delete, initialize (erase), list, write to, and read macros from a file.

Each macro consists of a name and a script and may contain commands, pauses, other macros, and text. Each macro file contains one or more macros. Macros are stored on your hard disk in a text file.

You can assign macros to function keys, selected keyboard keys, keys used with <Ctrl>, <Shift>, and <Alt>, or the middle mouse button on a three-button mouse.

**Schematic Design Tools** includes two macro files, **MACRO1.MAC** and **MACRO2.MAC** on the product disks. These files include macros for drawing, editing, file management, and setting **Draft's** environment.

You can create macros two different ways:

- ❖ Record entered keystrokes as you select commands in **Draft**.
- ❖ Write a macro script in a text editor.

To create or change macros, select the **MACRO** command from the main menu level menu. The **MACRO** menu at right appears.

| Macro      |
|------------|
| Capture    |
| Delete     |
| Initialize |
| List       |
| Read       |
| Write      |

- MACRO Capture** To create a macro, select **Capture**. Draft displays "Capture macro?".
- Press the key or keys to use to call the macro. The key(s) you press appears on the prompt line. See table 2-2 for a list of valid keys that can be assigned as macros.
- Press <Enter>. Draft displays "<macro>," showing Draft is in macro capture mode.
- In macro capture mode, Draft records any sequence of keystrokes, mouse button clicks, and mouse movements. Commands you normally perform in Draft can be recorded and executed later as macros.
- When you finish recording the macro keystrokes, choose one of the following:
- ❖ Press <M> or select **MACRO** to stop the **Capture** command at the main menu.
  - ❖ Press <Ctrl><End> to stop the **Capture** command anywhere in the application.

*Valid macro keys* A macro can be called by pressing selected keyboard keys, keys used with <Ctrl>, <Shift>, and <Alt> or the middle mouse button on a three-button mouse. The macro name of the middle button is **MMB**.

Table 2-2 on the next page shows the keys to which macros can be assigned. The **Alt+**, **Ctrl+**, and **Shift+** headings indicate the key you press in combination with a key listed in the left-hand column. The **Key** heading indicates that you press the key alone.



|      | Alt + | Ctrl+ | Shift+ | Key |
|------|-------|-------|--------|-----|
| A    | √     | √     |        |     |
| B    | √     | √     |        |     |
| C    | √     |       |        |     |
| D    | √     | √     |        |     |
| E    | √     | √     |        |     |
| F    | √     | √     |        |     |
| G    | √     | √     |        |     |
| H    | √     |       |        |     |
| I    | √     | √     |        |     |
| J    | √     | √     |        |     |
| K    | √     | √     |        |     |
| L    | √     | √     |        |     |
| M    | √     |       |        |     |
| N    | √     | √     |        |     |
| O    | √     | √     |        |     |
| P    | √     | √     |        |     |
| Q    | √     | √     |        |     |
| R    | √     | √     |        |     |
| S    | √     | √     |        |     |
| T    | √     | √     |        |     |
| U    | √     | √     |        |     |
| V    | √     | √     |        |     |
| W    | √     | √     |        |     |
| X    | √     | √     |        |     |
| Y    | √     | √     |        |     |
| Z    | √     | √     |        |     |
| Tab  |       |       | √      |     |
| Ins  |       |       |        | √   |
| Left |       | √     |        |     |

|       | Alt+ | Ctrl+ | Shift+ | Key |
|-------|------|-------|--------|-----|
| F1    | √    | √     | √      | √   |
| F2    | √    | √     | √      | √   |
| F3    | √    | √     | √      | √   |
| F4    | √    | √     | √      | √   |
| F5    | √    | √     | √      | √   |
| F6    | √    | √     | √      | √   |
| F7    | √    | √     | √      | √   |
| F8    | √    | √     | √      | √   |
| F9    | √    | √     | √      | √   |
| F10   | √    | √     | √      | √   |
| 1     | √    |       |        |     |
| 2     | √    |       |        |     |
| 3     | √    |       |        |     |
| 4     | √    |       |        |     |
| 5     | √    |       |        |     |
| 6     | √    |       |        |     |
| 7     | √    |       |        |     |
| 8     | √    |       |        |     |
| 9     | √    |       |        |     |
| 0     | √    |       |        |     |
| ^     |      | √     |        |     |
| =     | √    |       |        |     |
| -     | √    |       |        |     |
| \     |      | √     |        |     |
|       |      | √     |        |     |
| Right |      | √     |        |     |
| Pgup  |      | √     |        | √   |
| Pgdn  |      | √     |        | √   |

Table 2-2. Valid key combinations for macros.

Grouping macros by type of task and assigning an extending key to each type helps organize your macros. For example, use the <Alt><Function> keys to set the environment and the <Ctrl><Alpha> keys to draw schematics.

Within each group of macros, you may assign logical initials for functions. For example, a macro that places a junction may be named <Alt><J>.

*Nesting macros* A macro can call another macro or call itself from within a macro. When you are capturing a macro, type the key name of a previously saved macro. For example: Suppose you want to nest the macro assigned to F2 within a new macro. Type F2 at the appropriate time while you are capturing the new macro.

You may create a macro that calls itself, however the macro is recursive, or looping, and does not end until you press <Ctrl><Break>. To nest a macro inside another macro, insert the macro name, enclosed by curly brackets, inside the text of another macro. For example:

```
{F3}=sry{F2}()
```

*Pause* If you want the macro to pause and wait for a command or text, press <Ctrl><Home> followed by <Enter> and continue entering the remaining commands. When a macro containing such a command is running, it pauses for your input and resumes when you press <Enter> or click the left mouse button.

*Debugging macros* After capturing or writing a macro, test it for correctness. If you need to fix any problems, you may either capture it again or edit the macro using a text editor. Here are some hints for debugging:

- ❖ Print the file containing the macro and use it as a script for entering the commands manually.
- ❖ Use <Ctrl><Break> to stop a macro that doesn't stop on its own.
- ❖ If a macro does not run, another macro might still be running. When a macro is expecting <Enter> after <Macrobreak> and you use keyboard commands instead, the macro does not stop. If a macro runs the same commands endlessly, it is stuck in a loop. This sometimes happens when you nest macros and specify that a macro calls itself. It can also occur if you mix keyboard and mouse commands when you use macros assigned to the middle button.

- Initial macros* Initial macros run automatically each time you run **Draft**. You may use an initial macro to set the environment to suit your preferences or project. You specify the initial macro and the macro file containing it on the **Configure Schematic Design Tools** screen. You may specify only one initial macro at a time. For information about configuring **Draft** for macros, see *Macro Options* in *Chapter 1: Configure Schematic Tools*.
- MACRO Delete** To delete a macro, select **Delete**. **Draft** displays "Delete macro?" Type the key combination assigned to the macro you wish to delete, then press <Enter>.
- MACRO Initialize** This command erases all macros in the macro buffer. To erase all of the macros, select the **Initialize** command. **Draft** displays the prompt "Erase All Macros?"
- Select **No** to return to the main menu level, or **Yes** to erase all macros.
- MACRO List** **MACRO List** lists all the key combinations assigned to macros. To display the macro list, select **List**.
- MACRO Read** **MACRO Read** loads a macro file into an area of memory called the *macro buffer*, where they can be accessed by **Draft**. If the macro buffer already contains macros, the macros with unique key combination assignments are added to those in the buffer. Macros in the file with key combination assignments that are identical to key combinations assigned to macros in the buffer overwrite the macros in the buffer.
- To load a macro file, select **Read**. **Draft** displays the prompt "Read all macros from?"
- Enter the path and filename in which the macros are stored. **Draft** loads the macro file.

- 
- MACRO Write** When you capture macros **Draft** keeps them in memory, in the macro buffer. **MACRO Write** saves all macros currently in the macro buffer to a file. To save the macros to a file, select **Write**. **Draft** displays “Write all macros to?” Enter a filename. If the file you name already exists, it is overwritten.
- Macro files can be loaded automatically when **Draft** runs by entering the macro filename and the name of the initial macro in the **Macro Options** area of the **Configure Schematic Design Tools** screen (see *Chapter 1: Configure Schematic Tools*).
- Using macros** Before **Draft** can use macros in a macro file, it must read the file into the macro buffer. The macro—when called—runs from the buffer.
- To use a macro, run **Draft** and read the macro file into the macro buffer with the **MACRO Read** command.
- Calling a macro* To run a macro, press the key combination for that macro. All instructions in the macro script run.
- Macro buffer* The macro buffer defaults to 8192 bytes of memory. If the buffer fills, **Draft** displays a warning message. To increase buffer memory you can either change the buffer size or delete unused macros. See **Macro Options** in *Chapter 1: Configure Schematic Tools* for more information about macro buffer memory.

**Macro text files** A macro is a text file, and can be edited or created using a text editor or word processing program such as Edit File. The application you use must be able to save the macro file in text-only format.

*Macro syntax* The syntax of a macro definition is shown below.

{Macro Name} = Macro Script { }

- ❖ *Macro name* is a valid key, key combination, or the acronym MMB enclosed in curly brackets.
- ❖ The equal sign ( = ) indicates that commands follow.
- ❖ *Macro script* is the list of commands the macro runs.
- ❖ The empty curly brackets ( { } ) mark the macro's end.

The table below lists translations for command keys and macro names.

| Key       | Translation  |
|-----------|--------------|
| Alt       | \            |
| Ctrl      | ^            |
| Shift     | SHIFT        |
| Ctrl-Home | {MACROBREAK} |
| Enter     | {ENTER}      |
| Backspace | {RUBOUT}     |
| Escape    | {ESC}        |
| Up        | {U}          |
| Down      | {D}          |
| Left ←    | {L}          |
| Right →   | {R}          |

| Name      | Translation |
|-----------|-------------|
| Page Up   | {PGUP}      |
| Page Down | {PGDN}      |
| Home      | {HOME}      |
| End       | {END}       |
| Up        | {UP}        |
| Down      | {DN}        |
| Left ←    | {LEFT}      |
| Right →   | {RIGHT}     |
| Shift-Tab | {BACKTAB}   |
| Tab       | {^I}        |
| Insert    | {INS}       |
| Delete    | {DEL}       |

Table 2-3. Key translations.

When you create macros using a text editor, you may organize the macros any way you choose, and include any character with these restrictions:

- ❖ Use only characters representing OrCAD commands, text, or filenames in macro scripts.
- ❖ Avoid line breaks or paragraph breaks in long macros. You may use groups of spaces to force the macro to wrap on the screen.

- ❖ Use only MMB or valid key combinations from Table 2-2 for macro names.
- ❖ Do not use curly braces ({ or }) or equal signs (=) anywhere except where required by macro syntax.

When you finish writing the macro, name the file and save it in text-only format.

*Example: macro for cutting wires*

To cut a wire in **Draft**, use this macro instead of deleting and redrawing the entire wire. This macro places a junction on the wire, drags the junction to break the wire, and deletes the junction. To cut off the extra wire, put the cursor on the extra segment and select **DELETE Object Delete**.

```
{\B}=p j p {ESC} b d b e {U} {D} p d o d j {ESC} {}
```

*Example: macro for placing parts on grid*

After using the **Cleanup Schematic** processor to identify parts that are off grid, you can use this macro to find and move parts back onto the grid. At the *Find?* prompt, enter the name or part value of the part that is off grid. The macro copies, deletes, and gets the part. The part appears highlighted, ready for you to position it. To place the part, press <Enter>. If a part is already on grid, this macro does not move it off grid.

```
{\A}=f {macrobreak} b s b e d o d {esc} s g s y b g {macrobreak} p {esc} {}
```

*Macro comments*

Using a text editor, you may add comments to macros that remind you and others what each macro is for. Macros with remarks are also useful for quick reference. Follow these guidelines to add and preserve remarks in macro files.

- ❖ Place remarks before or after the macro, or in both positions. You may also insert paragraphs between macros. The remarks in these macros are shown in bold:

```
PLACE Junction {^P}=pjp{}  
{^P}=pjp{} PLACE Junction  
PLACE Junction {^P}=pjp{} for SuperSquig project
```

- ❖ Do not use the left curly brace ({} in remarks.
- ❖ Add remarks, macros, or edit existing remarks or macros with a text editor. Use the editor to alphabetize the list by remark or by macro name. Save the file in text-only format.
- ❖ Make a backup copy of the file and store it in a safe location such as another directory or on a diskette.
- ❖ Consider changing the extension of original macro files. For example:  

```
COPY SAMPLE.MAC SAMPLE.MAS
```
- ❖ Avoid writing over original macro files with **MACRO Write**. When you select **MACRO Read**, **Draft** ignores all text outside macros. When you select **MACRO Write**, **Draft** erases all comments placed in the file.
- ❖ Print the macro file to create a quick reference card.

Once you have a collection of macros, keeping track of what each macro does may get complicated, particularly if you share macro files with other OrCAD users. You may want to organize your macro files by establishing conventions for naming the macros and by adding remarks to your macro files.

**Middle mouse button macros**

This section describes a method for controlling multiple Draft macros using the middle mouse button.

For each macro you assign to the middle button, you need two macros. The first macro contains the commands for doing a task such as placing a junction. You save this macro in its own file. For example, the macro for placing a junction looks like this:

```
{mmb}=pjp{esc} {}
```

Save the macro to the following file:

```
put junct.mac
```

The second macro directs the application to read the macro file containing the first macro. You may either include the second macro in the macro file that you specified during configuration, or you may use the **MACRO Read** command to read the macro file.

For example, the macro for assigning the junction macro to the middle mouse button looks like this:

```
{^j}=mrput junct.mac{enter} {}
```

The file you save this macro to might be this:

```
mymacros.mac
```

If you develop a number of macros for your three-button mouse, you may find it helpful to create a subdirectory to contain macro files. If you create such a subdirectory, named `ORCADESP\SDT\MACRO` for this example, the second macro changes to this:

```
{^j}=mrc:\
ORCADESP\SDT\MACRO\put junct.mac{enter} {}
```

*Assignment macros*

Once you set up the macro files, you assign macros to the middle button using keyboard commands. For example:

```
{\b}=mrmacro_b.mac{enter}{}
{\d}=mrmacro_d.mac{enter}{}
{\g}=mrmacro_g.mac{enter}{}
{\j}=mrmacro_j.mac{enter}{}
{\k}=mrmacro_k.mac{enter}{}
{\s}=mrmacro_s.mac{enter}{}
{\w}=mrmacro_w.mac{enter}{}
{\z}=mrmacro_z.mac{enter}{}

```



*Individual macros*

```
PLACE Bus
  {mmb}=pb{}
  Saved in macro_b.mac
DELETE Block Begin
  {mmb}=dbb{macrobreak}e{}
  Saved in macro_d.mac
BLOCK Drag Begin
  {mmb}=bdb{macrobreak}e{macrobreak}p{}
  Saved in macro_g.mac
PLACE Junction Place
  {mmb}=pjp{esc}{}
  Saved in macro_j.mac
BLOCK Move Begin
  {mmb}=bmb{macrobreak}e{macrobreak}p{}
  Saved in macro_k.mac
BLOCK Save Begin
  {mmb}=bsb{macrobreak}ebg{}
  Saved in macro_s.mac
PLACE Wire Begin
  {mmb}=pwb{}
  Saved in macro_w.mac
ZOOM Out and Back
  {mmb}=zo{macrobreak}zi{}
  Saved in macro_z.mac
```

Creating efficient macros

When you capture a macro, you may press keys or click the mouse. When you write a macro, you may duplicate keystrokes and mouse clicks. Macro size and execution speed depend on the method you use to select commands. Pressing keys results in fewer macro instructions. In complex macros, using keystrokes:

- ❖ Speeds the macro up
- ❖ Increases its readability
- ❖ Minimizes its size and thereby maximizes the number of macros that the macro buffer may hold
- ❖ Frees more memory for the worksheet

The following examples of initial macros show the difference between a macro captured with keystrokes and the same macro captured with mouse clicks.

- ❖ Macro captured with keystrokes, 32 bytes:

```
{F1}={ENTER}sgvysdysxy{U}{D}{}
```

- ❖ Macro captured with mouse clicks and keystrokes, 364 bytes:

```
{F2}={ENTER}{D}{D}{D}{D}{D}{D}{D}{D}{D}{D}{D}{D}{D}
{D}{D}{ENTER}{D}{D}{D}{D}{D}{D}{D}{D}{D}{D}{R}{D}
{ENTER}{D}{D}{D}{ENTER}{ENTER}{ENTER}{D}{D}{D}{D}
{D}{D}{D}{D}{D}{D}{D}{D}{D}{D}{ENTER}{U}{U}{R}{U}
{U}{U}{D}{D}{ENTER}{ENTER}{ENTER}{D}{D}{D}{D}{D}
{D}{D}{D}{D}{D}{R}{D}{D}{D}{R}{D}{ENTER}{D}{D}{D}
{D}{D}{D}{D}{D}{D}{D}{D}{L}{D}{U}{U}{L}{D}{ENTER}
{ENTER}{D}{U}{}
```

You may also increase the speed at which macros run by selecting SET Macro Prompts No either before running the macro or as part of the macro. Figure 2-8 compares the execution times of F1 and F2 with Macro Prompts set On and Off.

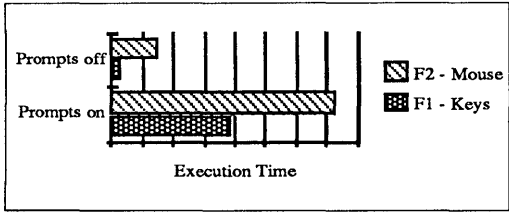

Figure 2-8. Macro execution times for key and mouse macros.

## PLACE

**PLACE** puts wires, buses, junctions, bus entries, labels, text, module ports, power, dashed lines, and hierarchical sheets on your worksheet.

Select **PLACE** from the main command menu. **Draft** displays the menu shown at right.

Place

|             |
|-------------|
| Wire        |
| Bus         |
| Junction    |
| Entry (Bus) |
| Label       |
| Module Port |
| Power       |
| Sheet       |
| Text        |
| Dashed Line |
| Stimulus    |
| Trace       |
| Vector      |
| Layout      |
| No Connect  |

### PLACE Wire

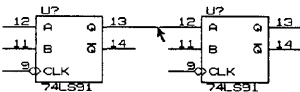

Select **PLACE Wire** to place wires in the worksheet. **Draft** displays:

|                      |
|----------------------|
| Begin Find Jump Zoom |
|----------------------|

To draw a wire, first place the pointer at the point on the worksheet where you want the wire to start.

Select **Begin**. **Draft** displays:

|                              |
|------------------------------|
| Begin End New Find Jump Zoom |
|------------------------------|

Draw the wire by moving the pointer. Use the following **PLACE Wire** commands to finish drawing the wire.

### *Begin*

Use the **Begin** command to:

- ❖ Start drawing a wire segment.
- ❖ Finish drawing a wire segment and begin a new one (if the wire you are drawing makes a 90° turn).

You can use **Begin** over and over again to draw a complex wire. As you move the pointer, a dashed line representing the wire is drawn.

To continue drawing the wire from a 90° turn, select **Begin** where the turn starts (point A in figure 2-9). You may also move to the end of the wire (point B in figure 2-9) and select either **Begin**, **End**, or **New** to place a wire segment. When you finish placing a wire segment with **Begin**, **End**, or **New**, the dashed line becomes a solid line. A dashed line shows placement of a wire segment has not been completed with the **Begin**, **End**, or **New** commands.

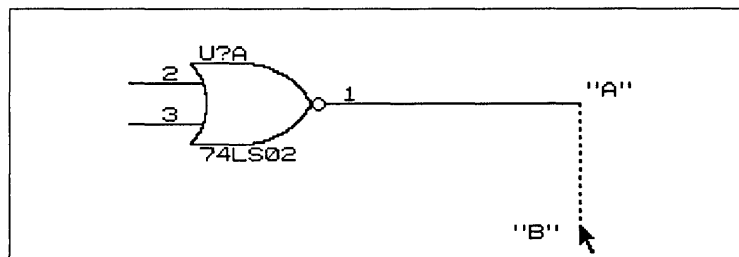

Figure 2-9. Drawing a wire.

Continue drawing the wire. To end the wire, select either **End** or **New**.

△ **NOTE:** See the Schematic Design Tools User's Guide for examples of macros that simplify wire placement.

- End* Select **End** when you are done drawing a wire. **Draft** returns to the main menu level.
- New* Select **New** when you are done drawing a wire and would like to start drawing another wire. **Draft** remains in the wire placing mode, and returns to the "Begin Find Jump Zoom" command line.

**PLACE Bus**

Select **Bus** to place buses on the worksheet. **Draft** displays:



A



B

Begin Find Jump Zoom

To draw a bus, place the pointer at the worksheet location where you want the bus to start. Select **Begin**. **Draft** displays:

Begin End New Find Jump Zoom

Draw the bus by moving the pointer. Select one of the **PLACE Bus** commands to finish drawing the bus.

*Begin*

Use the **Begin** command to to:

- ❖ Start drawing a bus segment.
- ❖ Finish drawing a bus segment and begin a new one (if the bus you are drawing needs to make a 90° turn).

You can use **Begin** repeatedly to draw a complex bus.

To continue drawing the bus from the 90° turn, select **Begin** where the turn starts. You may also move to the end of the bus and select either **Begin**, **End**, or **New** to fill it in.

Continue drawing the bus until you come to where you want it to end. To connect the bus to an end point, select either **End** or **New**.



***NOTE:** Buses with module ports attached to them are automatically labeled with the same name as the module port, and therefore do not need an extra label.*

*End*

With the pointer at the end point, select **End**. **Draft** returns to the main menu level.

*New*

With the pointer at the end point, select **New**. **Draft** stays in bus-placing mode and returns to the "Begin Find Jump Zoom" command line. Drawing a bus is identical to drawing a wire (see the **PLACE Wire** command).

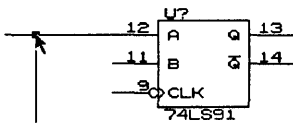
**PLACE Junction**

On a worksheet, many wires and buses connect or cross each other. Junctions are placed on the worksheet to distinguish a connection from a cross-over. If more than two wires or buses connect to a common node, place a junction there to tell the **Check Electrical Rules** reporter and **Create Netlist** processor that the node is a physical connection.

If you don't place a junction at an intersection of wires or buses, **Check Electrical Rules** and **Create Netlist** interpret the intersection as a cross-over.

In many designs, you may want to connect a wire at 90° angles to a bus. If you do, you must place a junction at the connect point. Junctions are not required if you use a bus entry (see the **PLACE Entry (Bus)** command).

To place a junction in the worksheet, select **PLACE Junction**. **Draft** displays:

|       |      |      |      |
|-------|------|------|------|
| Place | Find | Jump | Zoom |
|-------|------|------|------|

Position the pointer where you want the junction and select **Place**. **Draft** remains in "PLACE Junction" mode until you press the <Esc> key.

### PLACE Entry (Bus)



A



B

Use the **Entry (Bus)** command to place bus entries on a worksheet. Use bus entries for aesthetic purposes to connect wires or other buses to a bus. In the picture at the left, A shows a series of wire bus entries and B shows a bus entry used for a bus turn.

When you select **PLACE Entry (Bus)**, **Draft** shows the last bus entry selected, with this command line:

```
Place / \ Wire Bus Find Jump Zoom
```

To place a bus entry, select **Place**. Select the **/** or **\** commands to change the bus entry angle. **Draft** shows the last bus entry angle when you select **PLACE Entry (Bus)**.

Select **Wire** to place wire entries. Use this command when a wire is to exit or enter a bus from another object.

Select **Bus** to place bus entries. Use this command when a bus makes a turn or is joined to another bus.

△ **NOTE:** *Junctions are not required to connect a bus entry to a bus. (See **PLACE Junction.**)*

**PLACE Label**

This is a label

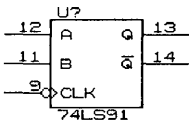

A label is an identifier placed on a worksheet that connects signals (wires and buses) together without actually drawing the wires connecting them. You can place labels horizontally or vertically on a worksheet.

Labels are *not* comments. Labels have meaning for other tools, such as **Create Netlist**. To place a comment on the worksheet, use the **PLACE Text** command.

To place a label, select **Label**. **Draft** displays the prompt: "Label?" Enter the name of the label. **Draft** displays:

|       |             |       |        |         |      |
|-------|-------------|-------|--------|---------|------|
| Place | Orientation | Value | Larger | Smaller | Find |
|-------|-------------|-------|--------|---------|------|

*Place* Select **Place** to place the label on the worksheet.

When the label is placed, the "Label?" prompt returns. You can place another label or press <Esc> to return to the main menu level.

△ *NOTE: If you always stay on grid, the label is always correctly positioned to connect to a wire or bus. Just move the pointer on the wire or bus to place the label.*

*Orientation* Select **Orientation** to change the orientation of the label from **Horizontal** to **Vertical** or vice versa.

*Value* Select **Value** to enter a value for the label. When you select **Value**, the prompt "Text?" displays followed by the current value. Edit the value by moving the cursor with the <←> and <→> keys, and the <Home> and <End> keys, erasing characters with <Backspace> and <Delete>, and adding new characters with the alphanumeric keys. When you finish editing the label's value, press <Enter>.

*Larger* Select **Larger** to make a label larger. Select **Larger** as many times as you like until the label is large enough.

*Smaller* Select **Smaller** to make the label smaller. As with **Larger**, you may select **Smaller** over and over.



*Placing labels correctly*

In order for Check Electrical Rules and Create Netlist to associate internal and bus member labels with wires and buses, you must place labels in “contact” with the bus or wire. The bottom edge of the leftmost character is the “hotpoint” of a label. Some portion of it must be right next to the bus or wire to establish contact.

Figure 2-10 shows correct label positions for both vertical and horizontal wires. Notice the hotpoints for each label (bottom edge of the character “L”) are next to the wire.

Figure 2-11 shows incorrect label positions. None of the label hotpoints are next to the wire.

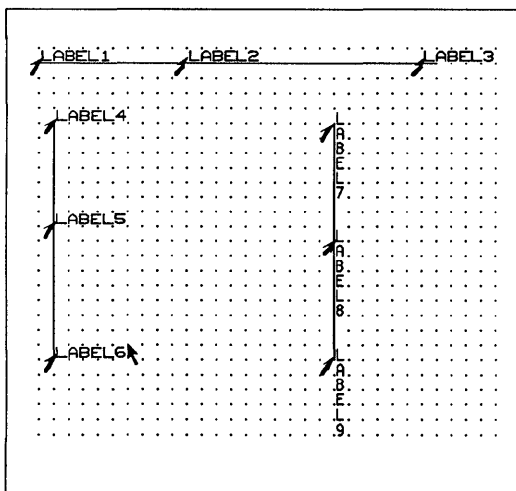

Figure 2-10. Correct label positions.  
The right-pointing arrows indicate the labels' hotpoints.

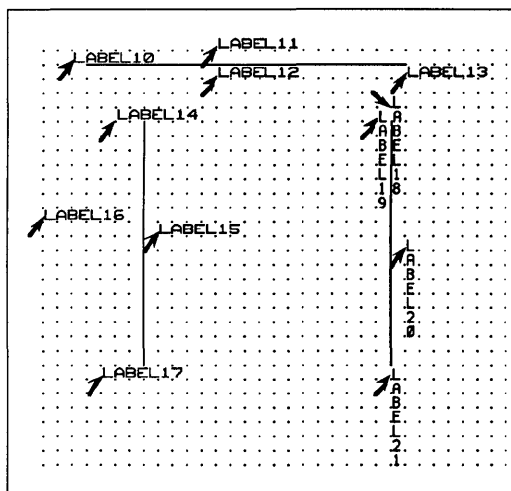
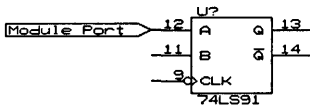

Figure 2-11. Incorrect label positions.

## PLACE Module Port



A module port is used to connect signals on the current sheet to signals on other worksheets. Unspecified module ports may be used to transfer isolated power from one sheet to another. Module ports may be connected to either wires or buses.

Signals remaining internal to the worksheet should use labels, not module ports.

All module ports and labels with the same name are considered to be electrically connected, just as are all labels with the same name.

To place a module port, select **Module Port** command. The prompt “Module Port Name?” displays. Enter the module port name. **Draft** displays the menu shown at right.

|               |
|---------------|
| Input         |
| Output        |
| Bidirectional |
| Unspecified   |

Select **Input** if the module port is used as a signal input, **Output** if the module port is used as a signal output, **Bidirectional** if the module port is used as a bidirectional signal, or **Unspecified** if the module port is used to transfer power or “don’t care” signals. Figure 2-12 shows the four types of module ports and their default styles.

After selecting one of the commands shown at right, **Draft** draws a preliminary version of the module port with its name.

|               |    |
|---------------|----|
| Input         | >  |
| Output        | <  |
| Bidirectional | <> |
| Unspecified   |    |

You may move it before placing it.

The following command line displays:

|       |       |      |       |      |      |      |
|-------|-------|------|-------|------|------|------|
| Place | Value | Type | Style | Find | Jump | Zoom |
|-------|-------|------|-------|------|------|------|

Select **Place** to place the module port on the worksheet. The prompt “Module Port Name ?” displays, so that you may place another module port. Press <Esc> to return to the main menu level.

Before placing the module port, you can also change its **Value, Type, or Style**. A module port's value is whatever you typed after "Module Port Name?" Its type is **Input, Output, Bidirectional, or Unspecified**. Its style is how it looks on the screen. If you select **Style**, you can choose from the options shown on the next page.

A module port's style is independent from its type. For example, a **Both pointing** style does not necessarily mean the module port is **Bidirectional**.

Module Port Style

- Right pointing
- Left pointing
- Both pointing
- Neither pointing

△ *NOTE: An unspecified module port must be specified when isolated power is transferred between worksheets. For more information, see Chapter 10: Create Netlist.*

The figure below shows the four types of module ports with their default styles.

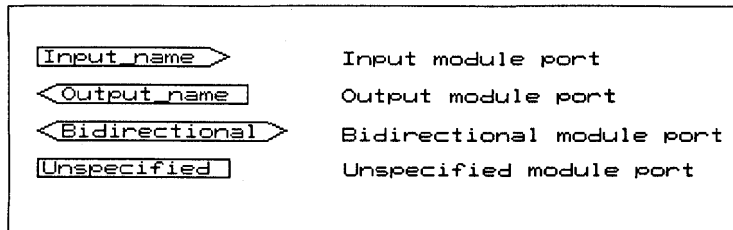
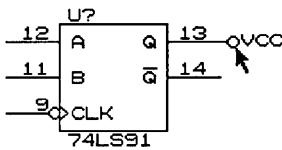

Figure 2-12. Types of module ports.

△ *NOTE: Module ports are not intended to be used as physical connectors, such as DB-9, and so on. Physical connectors are objects that should be created as library parts. For information on working with connectors, see Chapter 10: Create Netlist.*

**PLACE Power**

Use **PLACE Power** to place power supply objects on the worksheet.

To place a power object on a worksheet, select **Power**. **Draft** displays:

| Place | Orientation | Value | Type | Find |
|-------|-------------|-------|------|------|
|-------|-------------|-------|------|------|

The power object appears on the screen, ready to be positioned and placed on the worksheet. Before placing the power object on the worksheet, you can change its **Orientation**, **Value**, or **Type**.

If you select **Orientation**, you can choose **Top**, **Bottom**, **Left**, or **Right**.

△ *NOTE: The power pin default is a circle with a value of VCC. When you execute **PLACE Power**, the orientation returns to **Top**. However, type and value will be whatever was set previously.*

A power object's **Value** is the text (for example, VCC) associated with it. If you select **Value**, **Draft** displays the prompt "Power Value? xxx" where xxx represents the current value. You can backspace over the current value or append to it. Enter the new value (for example, +5, GND, + 5 VDC, -12 VDC, VSS, VEE, or any other text string). **Draft** returns to the main menu level.

A power object's **Type** is its appearance on the screen. If you select **Type**, you can choose **Circle**, **Arrow**, **Bar**, or **Wave**.

Select **Place** to place the power object where you want it on the worksheet. Then, press <Esc> to return to the main menu level.

If you use the **Create Netlist** processor, see *Chapter 10: Create Netlist* for information on handling isolated power such as in battery backup and other applications.

Figure 2-13 shows the four kinds of power objects and their orientations.

|        | Top      | Bottom   | Left  | Right |
|--------|----------|----------|-------|-------|
| Circle | VCC<br>○ | VCC<br>⊙ | VCC ⊖ | ⊖VCC  |
| Arrow  | VCC<br>↑ | VCC<br>↓ | VCC ← | →VCC  |
| Bar    | VCC<br>┆ | VCC<br>┆ | VCC ┆ | ┆VCC  |
| Wave   | VCC<br>┆ | VCC<br>┆ | VCC ┆ | ┆VCC  |

Figure 2-13. Circle, Arrow, Bar, and Wave power objects and their orientations.

## PLACE Sheet

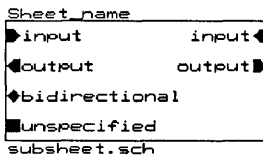

In **Draft** you can create hierarchical designs using *sheet symbols*. A sheet symbol, which represents a worksheet in a hierarchy, contains *net names*. The net names connect signals on the active worksheet to the sheet the symbol represents.

A *sheet net* is the way a connection is made between the signal attached to the sheet net on the current sheet and the module ports on the worksheet represented by the sheet symbol.

To place a sheet symbol, select **Sheet**. **Draft** displays:

```
Begin Find Jump Zoom
```

Select **Begin**, outline the area, then select **End** to finish it. **Draft** then displays:

```
Add-Net Delete Edit Name Filename Size
```

Pointer movement is now restricted to the left and right sides of the box of the hierarchical sheet, the proper locations for sheet names and nets.

*Add-Net*

Use **Add-Net** to add sheet nets so that connections can be made between worksheets. To add a net sheet, place the pointer at the location where you want the name and select **Add-Net**. **Draft** displays the prompt "Net Name?" Enter the net name. **Draft** displays the menu shown below. Select the appropriate type for your sheet net.

For more information, see *Editing sheets* earlier in this chapter, and the discussion of hierarchies in the *Schematic Design Tools User's Guide*.

```
Input      |>
Output     <|
Bidirectional <>
Unspecified ||
```

*Delete*

To delete sheet nets, place the pointer at the net's location and select **Delete**.

*Edit* To edit a sheet net, place the pointer at the net's location and select **Edit**. **Draft** then displays a menu allowing you to choose between **Name** and **Type**.

To edit the net name, select **Name**. Edit the net name by positioning the cursor with the <←> and <→> keys or the <Home> and <End> keys, erasing characters with <Backspace> and <Delete>, and adding new characters with the alphanumeric keys. When you finish editing the net name, press <Enter>.

To edit the net type, select **Type**. You can then choose **Input**, **Output**, **Bidirectional**, or **Unspecified**.

*Name* Use the **Name** command to edit the sheet name. The initial sheet name is a question mark (?) located at the top of the sheet. Typical sheet names are "Memory Array" or "Dynamic RAM Refresh circuitry."

To specify a sheet name, select **Name**. **Draft** displays "Sheet Name?" followed by the current sheet name. Edit the sheet name using the editing techniques discussed above. When you finish editing the sheet name, press <Enter> to place it at the top of the sheet.

*Filename* Use **Filename** to change the filename of the file representing the hierarchical worksheet. **Draft** automatically produces a filename based on the date and time of day the sheet symbol was placed in the schematic. This ensures no two filenames will be the same.

Edit this filename using the editing techniques discussed above. When you finish, press <Enter>.

*Size* **Size** increases or decreases the sheet size. When you select **Size**, **Draft** displays:

|     |      |      |
|-----|------|------|
| End | Jump | Zoom |
|-----|------|------|

**Draft** automatically positions the pointer on the lower right corner of the sheet. To change sheet size, move the pointer until you reach the desired size. Then select **End**.

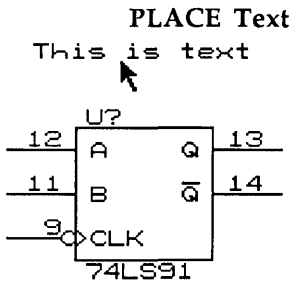

Use **PLACE Text** to place comments on your worksheet. Comments are useful for including revision history, tolerance, and other information in the worksheet.

When you select **Text**, **Draft** displays the prompt "Text?" Enter the text you want as a comment. When you finish, press <Enter>. **Draft** displays the command line:

```
Place Orientation Value Larger Smaller Find Jump
```

*Place* Select **Place** to place the text on the worksheet.

When the text is placed, the "Text?" prompt returns. You can place more text or press <Esc> to return to the main menu level.

*Orientation* Select **Orientation** to change the orientation of the text from **Horizontal** to **Vertical** or vice versa.

*Value* Select **Value** to enter a value for the text. When you select **Value**, the prompt "Text?" displays followed by the current value. Edit the value by positioning the cursor with the <←> and <→> keys, and the <Home> and <End> keys, erasing characters with <Backspace> and <Delete>, and adding new characters with the alphanumeric keys. When you finish editing the value, press <Enter>.

*Larger* Select **Larger** to make the text larger. You may select **Larger** more than once until the text is as large as you like.

*Smaller* Select **Smaller** to make the text smaller. As with **Larger**, you may select **Smaller** over and over.



**PLACE Dashed Line**

**Dashed Line** places a dashed line on the worksheet. This is useful for setting off sections of your design. You can then label sections with comments constructed with **PLACE Text**.

Placing a dashed line is similar to placing a wire. When you select **Dashed Line**, **Draft** displays:

|                      |
|----------------------|
| Begin Find Jump Zoom |
|----------------------|

To draw a dashed line, select **Begin**. Then move the pointer to draw the line. End the line using **End** and change direction using **Begin**. Use **New** to end the current line, and begin a new line at a different location with **Begin**.

**PLACE Trace Name**

A trace is a special marker placed on a worksheet that identifies a node to be traced in the digital simulation of the design. To keep the design from being cluttered, the trace name is not visible on the schematic. To view the contents of a trace, use the **INQUIRE** command.

To place a trace, select **Trace Name**. **Draft** displays the prompt: "Trace Name?" Enter the name you wish this signal to be displayed as in the simulator. **Draft** displays:

```
Place Value Find Jump Zoom
```

*Place*

Select **Place** to place the trace on the worksheet. After placing the trace, the "Trace Name?" prompt returns. You can place another trace or press <Esc> to return to the main menu level.



*NOTE: If you always stay on grid, the trace is always correctly positioned to connect to a wire or bus. Just move the pointer on the wire to place the trace.*

*Value*

Select **Value** to edit value for the trace before you place the trace. When you select **Value**, the prompt "Trace Name?" displays followed by the current value. Edit the value using the editing techniques describe previously. When you finish editing the trace name, press <Enter>.

*Trace name format*

A trace may be placed on either a net or a bus. The trace name may consist of any printable characters including spaces, except a period. If the display name contains a left or right square bracket, then the name is considered to be a bus name and the trace must be placed on a bus. For buses, the format of the bus may be specified after the right square bracket in the name. The format is a single character from the following list:

|   |                    |   |                |
|---|--------------------|---|----------------|
| B | Binary format      | D | Decimal format |
| H | Hexadecimal format | O | Octal format   |

*Examples*

```
ADD 5
DATA[0..15]D
```

**PLACE Vector**



A vector is a special marker placed on the worksheet that identifies a node to be stimulated by a test vector. The test vectors are referred to by column number, therefore, the vector placed on the worksheet has a vector column value. To keep the design from being cluttered, the vector column is not visible on the schematic. To view the vector column number of a particular vector, use the **INQUIRE** command.

To place a vector, select **Vector. Draft** displays the prompt: "Vector Column?" Enter the column number of the vector. **Draft** displays:

|       |       |      |      |      |
|-------|-------|------|------|------|
| Place | Value | Find | Jump | Zoom |
|-------|-------|------|------|------|

*Place*

Select **Place** to place the vector on the worksheet.

When the vector is placed, the "Vector Column?" prompt returns. You can place another vector or press <Esc> to return to the main menu level.



***NOTE:** If you always stay on grid, the vector is always correctly positioned to connect to a wire or bus. Just move the pointer on the wire to place the vector.*

*Value*

Select **Value** to edit the vector column. When you select **Value**, the prompt "Vector Column?" displays followed by the current value. Edit the value by positioning the cursor with the <←> and <→> keys, and the <Home> and <End> keys, erasing characters with <Backspace> and <Delete>, and adding new characters with the alphanumeric keys. When you finish editing the vector column, press <Enter>.

*Vector column format*

The vector column indicates which column of the test vector file to use when the simulation is run. The column number is a decimal whole number such as 5.

**PLACE Stimulus**

A stimulus is a special marker placed on a worksheet that identifies a node to be stimulated by in the digital simulation of the design. The stimulus is an expression describing the pattern of logic states. To keep the design from being cluttered, the stimulus pattern is not visible on the schematic. To view the contents of the stimulus, use the **INQUIRE** command.

To place a stimulus, select **Stimulus**. **Draft** displays the prompt: "Stimulus?" Enter the value of the stimulus.

**Draft** displays:

|       |       |      |      |      |
|-------|-------|------|------|------|
| Place | Value | Find | Jump | Zoom |
|-------|-------|------|------|------|

*Place*

Select **Place** to place the stimulus on the worksheet.

When the stimulus is placed, the "stimulus?" prompt returns. You can place another stimulus or press <Esc> to return to the main menu level.



***NOTE:** If you always stay on grid, the stimulus is always correctly positioned to connect to a wire or bus. Just move the pointer on the wire to place the stimulus.*

*Value*

Select **Value** to edit the value of the stimulus. When you select **Value**, the prompt "Stimulus?" displays followed by the current value. Edit the value by positioning the cursor with the <←> and <→> keys, and the <Home> and <End> keys, erasing characters with <Backspace> and <Delete>, and adding new characters with the alphanumeric keys. When you finish editing the value, press <Enter>.

*Stimulus value format*

The stimulus describes the pattern of logic states to be applied to a net in the simulation. The pattern is described using a series of functions. A value must have a minimum of one function. The maximum is limited to the number of functions that can be placed in the text associated with the stimulus object.

There are two types of functions: set and branch. At least one space is required between each function.

### *Set function*

A set function consists of two variables: the time and the value. These two variables are separated by a colon. The time is an unsigned whole number. The value is a single letter from the following list:

- 0 Set to 0
- 1 Set to 1
- U Set to undefined
- Z Set to high impedance
- T Toggle

For example, the function to set the signal to a 1 at time 50 is 50:1.

△ *NOTE: Separate multiple functions with spaces.*

### *Branch function*

The branch function consists of two variables: the time the branch is to occur and the time to branch to. The two variables are separated by :G:. Both of the time values are unsigned whole numbers.

For example, the function to branch from time 450 back to time 400 is 450:G:400.

△ *NOTE: Only one branch function is allowed per stimulus value.*

*Examples* The following examples show proper stimulus expressions:

```
0:0 100:T 200:G:100
0:U 37:1 59:Z 83:G:37
0:U 50:0 100:Z 150:1 200:Z 250:U 255:0
0:1 20:0 40:Z 60:U 80:G:0
```

**PLACE NoConnect** × A no-connect is a special symbol that identifies a pin on a device that is intentionally to be left unconnected. This object causes reports that show unconnected pins to ignore pins with no-connect symbols. No-connect pins should not be connected together. No-connects may not be placed on buses, sheet nets, module ports, labels, power objects, or bus entries. You can place no-connects anywhere, but the other tools will not recognize the no-connect.

To place a no-connect, select **NoConnect**. **Draft** displays:

|                      |
|----------------------|
| Place Find Jump Zoom |
|----------------------|

*Place* Select **Place** to place the no-connect on the worksheet.

You can place another no-connect or press <Esc> to return to the main menu level.

△ ***NOTE:** If you always stay on grid, the no-connect is always correctly positioned to connect to a pin. Just move the pointer on the pin to place the no-connect.*

## PLACE Layout



A layout object is a special marker used to give a layout directive to **PC Board Layout Tools**. The layout directive specifies the routing conditions to be used with the net on which the layout object is placed. To keep the design from being cluttered, the layout directive is not visible on the screen, but the symbol is. To view the contents of the layout directive, use the **INQUIRE** command.

To place a layout object on the worksheet, select **Layout**. **Draft** displays the prompt: "Layout Directive?" Enter the layout directive. Layout directives and their format are described below.

**Draft** displays:

|       |       |      |      |      |
|-------|-------|------|------|------|
| Place | Value | Find | Jump | Zoom |
|-------|-------|------|------|------|

The **Place** and **Value** commands are described at the end of this section.

### *Layout directive format*

The layout directive consists of a series of characteristics that describe the conditions the net is to have when routing in OrCAD's Release IV **PC Board Layout Tools**. There are six net characteristics. If any of the six are not specified, the net characteristics not specified default to the net conditions specified in the **PC Board Layout Tools** configuration. At least one net characteristic must be present and up to all six may be present. A minimum of one space is required between layout directives.

The six conditions are: width, isolation, via, layers, pattern, and strategy. A net characteristic is followed by net conditions enclosed in a pair of parenthesis ( ). The general format for a layout directive is:

NetCharacteristic(NetConditions)

When you have more than one layout directive, use a space to separate layout directives.



**NOTE:** Use the abbreviations: *in* to specify inches, and *mm* to specify millimeters. *in* and *mm* should not be followed by a period.

The layout directives are:

- ❖ **Width**(*trackwidth units*) where *trackwidth* is a decimal number and *units* is either **in** or **mm**.

*Examples*                      Width(.010in)  
    Width(.25mm)

- ❖ **Isolation**(*metaltometal units, viatovia units*) where *metaltometal* and *viatovia* are decimal numbers and *units* is either **in** or **mm**.

*Examples*                      Isolation(.025in, .050in)  
    Isolation(.60in, 1.2mm)

- ❖ **Via**(*type, diameter units, drillsize units*) where *type* is one of **Through**, **Buried**, or **Blind**; *diameter* and *drillsize* are decimal numbers; and *units* is either **in** or **mm**.

*Examples*                      Via(Through, .035in, .022in)  
    Via(Buried, .80mm, .50mm)

- ❖ **Layer**(*first, second*) where *first* and *second* are unsigned whole numbers.

*Examples*                      Layer(1, 4)  
    Layer(2, 3)

- ❖ **Pattern**(*type*) where *type* is one of **Tree**, **Chain**, or **Comb**.

*Example*                      Pattern(Tree)

- ❖ **Strategy**(*type*) where *type* is one of **Normal**, **Flexible**, **Extensive**, **NoVia**, **90Degree**, or **Power**.

*Example*                      Strategy(Extensive)



△ *NOTE: For an explanation of the various conditions and their effects in routing, see the PC Board Layout Tools Reference Guide.*

**Place** Use **Place** to place the layout object on the worksheet. When the layout object is placed, the "Layout Directive?" prompt returns. To place another layout object, enter another layout directive. If you don't want to place another layout object, press <Esc> to return to the main menu level.

△ *NOTE: If you always stay on grid, the layout symbol is always correctly positioned to connect to a wire or bus. Just move the pointer on the wire to place the layout symbol.*

**Value** Select **Value** to edit the layout directive. When you select **Value**, the prompt "Layout Directive?" displays followed by the current value. Edit the value using the editing techniques described previously. When you finish editing the label's value, press <Enter>.

**QUIT**

Use **QUIT** to enter and leave hierarchical worksheets, load, update, and write to files, clear the worksheet, suspend to DOS, and abandon edits.

Select **QUIT**. The menu shown at right displays.

```
Quit FILENAME.SCH
Enter Sheet
Leave Sheet
Update File
Write to File
Initialize
Suspend to System
Abandon Edits
Run User Commands
```

**QUIT Enter Sheet**

Use the **Enter Sheet** command to view a schematic represented by a sheet symbol in a hierarchical design. To edit the schematic nested inside the one you are working on, select **Enter Sheet**.

If you have made any changes to the current worksheet without saving it, **Draft** displays "Enter - Abandon changes made?"

This message means that unless you save your changes you will lose them. Select **No** to cancel the **Enter Sheet** command. If you select **Yes**, all changes made during this work session are lost, and **Draft** displays:

```
Enter Leave Find Jump Zoom
```

Place the pointer inside the sheet symbol for the subsheet you wish to enter and select **Enter sheet**. For information about saving your latest design session to a file, see the **QUIT Update File** command.

**Draft** returns the **Enter Sheet** menu, so you can enter other subsheets. Press <Esc> to return to the main menu level.

**QUIT Leave Sheet**

To leave a subsheet, select **Leave Sheet**. When you invoke this command, you move one level up in the schematic hierarchy. If you are at the top of the schematic hierarchy, **Draft** briefly displays the error message "ERROR : Already at the Root Level."

**QUIT Update File**     **Update File** writes your latest worksheet design session to a file.

To update a file, select **Update File**. If the current worksheet had been previously loaded from a file, the file is updated. If the current worksheet is unnamed, **Draft** responds "Write to File?" Enter the desired filename.

To update a file other than the current file, use the **QUIT Write to File** command.

Press <Esc> to return to the main menu level.

**QUIT Write to File**     **Write to File** saves the current worksheet to any file you specify. When you choose **Write to File**, **Draft** displays "Write to File?"

Enter the desired filename. **Draft** saves the worksheet to the file specified and then returns the **QUIT** menu.

Press <Esc> to return to the main menu level.

**QUIT Initialize**     **Initialize** either loads a worksheet file or erases everything from it, thus clearing it. To perform these tasks, select **QUIT Initialize**.

If there are parts on the worksheet and you have made changes since the file was loaded or saved, **Draft** displays "Initialize - Are you sure?" Select **No** to cancel the **Initialize** command and return to the main menu level. Select **Yes** to clear the worksheet.

With a blank worksheet, **Draft** displays "Load File?" Enter the name of the file to load. If the file exists, the worksheet loads and displays. If the file does not exist, **Draft** displays a blank worksheet and the message "<<<new worksheet>>>."

Press <Esc> to return to the main menu level.

**QUIT Suspend to System**

**Suspend to System** temporarily leaves **Draft** and the worksheet, saves the worksheet in memory, and returns to the operating system. Once you have suspended **Draft**, you may run operating system commands, including using other programs, so long as there is enough system memory.

▲ **CAUTION:** *Always save your worksheet to a disk file before using **Suspend to System**.*

To suspend to the operating system, select **Suspend to System**. **Draft** suspends operation, loads the system command interpreter, and adds an additional ">" to the system command prompt. This is a reminder that **Draft** is suspended and in the "background."

To return to **Draft**, type **EXIT** at the system prompt. **Draft** then returns to the "foreground" and the worksheet you were working on displays.

**QUIT Abandon Edits**

Select **Abandon Edits** to exit **Draft** and return to the **Schematic Design Tools** screen. If parts have been placed on the worksheet since the last update, **Draft** displays "Abandon - Are you sure?". Select **No** to cancel the command. Select **Yes** to quit and return to the **Schematic Design Tools** screen.

**QUIT Run User  
Commands**

Use this command to quickly exit **Draft** and run an externally-defined operating system command.

Select **Run User Commands**. **Draft** suspends to the operating system and issues the command **DRAFTUSR**. **DRAFTUSR** should be an executable (compiled) program or a set of operating system commands. **DRAFTUSR** may be located in the current design directory or elsewhere in the system, in which case, the path the operating system searches must be set to find **DRAFTUSR**. For more information on setting the search path, see your operating system's configuration documentation.

After **DRAFTUSR** runs to completion, **Draft** prompts "Press any key to continue." Press any key to return to **Draft**.



***NOTE:** It is possible to use macros and the **BLOCK ASCII Export** command to create **DRAFTUSR** commands. For example, you can set up a macro to move to a clear area of a schematic, place one or more lines of text, and do a **BLOCK ASCII Export** of this text to the current directory. The macro could then select **QUIT Run User** to perform the tasks specified in the exported text.*

## **REPEAT**

Use **REPEAT** to duplicate the last entered object, label, or text string and place it on the worksheet.

The location of the duplicate object, label, or text is determined by the Repeat parameters specified with **SET Repeat Parameters**. You can also use **SET Repeat Parameters** to automatically increment or decrement the numeric suffix of a duplicated module port, label, or text string. For details on the **SET Repeat Parameters** command, see the *SET* command on the next page.

For an example of how to use the **REPEAT** command, see chapter 6 in the *Schematic Design Tools User's Guide*.

## SET

Use **SET** to control the following **Draft** options:

- ❖ Panning the screen automatically
- ❖ Creating backup files
- ❖ Dragging buses when rubberbanding
- ❖ Ringing the error bell
- ❖ Having the left mouse button execute <Enter> when released
- ❖ Macro prompting
- ❖ Drawing non-orthogonal wires
- ❖ Showing pin numbers
- ❖ Turning off the standard title block
- ❖ Displaying pointer coordinates, grid dots, and grid references
- ❖ Release the pointer from the stay-on-grid constraint
- ❖ Setting repeat parameters
- ❖ Changing the worksheet size, A through E
- ❖ Making certain items visible or invisible in zoom scale 2

To change the status of an option, select **SET**. **Draft** displays the menu shown at right.

If you prefer options other than the defaults, you may change them automatically every time **Draft** runs using an initial macro. See the **MACRO** command in this chapter and *Chapter 1: Configure Schematic Tools* for information about initial macros.

Set

|                   |     |
|-------------------|-----|
| Auto Pan          | YES |
| Backup File       | YES |
| Drag Buses        | NO  |
| Error Bell        | YES |
| Left Button       | NO  |
| Macro Prompts     | YES |
| Orthogonal        | YES |
| Show Pins         | YES |
| Title Block       | YES |
| Worksheet Size    | A   |
| X,Y Display       | NO  |
| Grid Parameters   |     |
| Repeat Parameters |     |
| Visible Lettering |     |

**SET Auto Pan**     **Auto Pan** controls movement past the screen boundary. While **Auto Pan** is turned on, when the pointer crosses a screen boundary, the screen pans in that direction.

When you select **Auto Pan**, you then choose between **Yes** and **No**. **Yes** turns on auto panning; **No** turns it off.

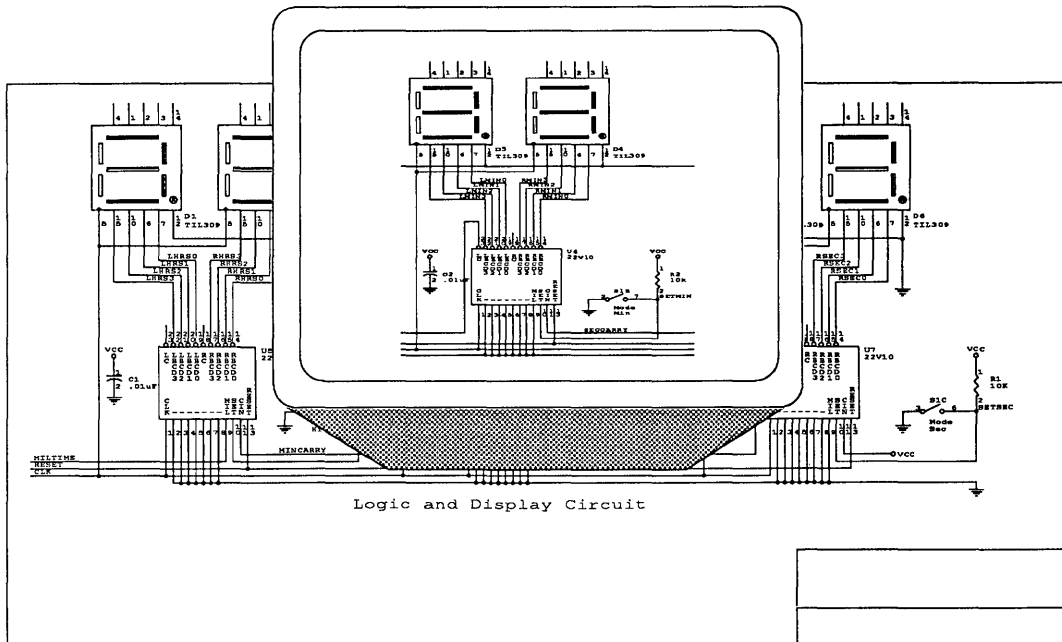

Figure 2-14. Panning changes the area of the schematic that displays.

**SET Backup File**     **Backup File** controls whether or not **Draft** creates a backup file of your worksheet when you write or update files using the **QUIT** command. The backup file contains the previous version of your edited worksheet.

When you select **Backup File**, you then choose between **Yes** and **No**. **Yes** turns on the creation of backup files; **No** turns it off.

△ **NOTE:** Turning off **Backup File** can be dangerous. If your file should accidentally be damaged or erased, you will be unable to recover it.



**SET Drag Buses** Use **Drag Buses** to stretch buses, rubberband-like, when you use the **BLOCK Drag** command. Because there are more points to locate when rubberbanding, system performance slows down when you use **BLOCK Drag** with **Drag Buses** turned on.

When you select **Drag Buses**, you then choose between **Yes** and **No**. **Yes** turns on rubberbanding buses; **No** turns it off.

**SET Error Bell** **Error Bell** turns the error bell (your computer's speaker) on and off. When you turn this option on, error messages and errors sound the speaker.

When you select **Error Bell**, you then choose between **Yes** and **No**. **Yes** turns on the error bell; **No** turns it off.

**SET Left Button** When **Left Button** is on, releasing the left mouse button executes the <Enter> key for command line commands only. Pressing the left mouse button continues to select the command highlighted in pop-up menus.

For example, suppose you select the **PLACE Wire** command and the "Begin Find Jump Zoom" command line displays at the top of the screen. To select **Begin** with the mouse when **SET Left Button** is turned off, you click the left button once to display the pop-up menu and once again to select **Begin**. When **SET Left Button** is turned on, you instead press the left button and hold it down while you move the highlight to **Begin**, then release the left button. This selects **Begin** and saves one button click.

When you select **Left Button**, you then choose between **Yes** and **No**. If you select **Yes**, releasing the left button on your mouse executes <Enter>. If you select **No**, releasing the left button on your mouse does not execute <Enter>.

**SET Macro Prompts**

When **Macro Prompts** are turned on, the commands making up your macros display on the screen when the macro runs. Turn **Macro Prompts** on when debugging macros or to watch the commands being performed when you run the macro.

After selecting **Macro Prompts**, you choose between **Yes** and **No**. **Yes** turns on macro prompts; **No** turns them off.

△ **NOTE:** *Setting Macro Prompts to No turns screen redraws off when a macro runs. This speeds up macro execution. As a result, Auto Pan is set to No during macro execution and macros using the ZOOM command won't work.*

**SET Orthogonal**

When **Orthogonal** is on, wires and buses are drawn orthogonally (perpendicular to each other). When turned off, wires and buses can be drawn at any angle.

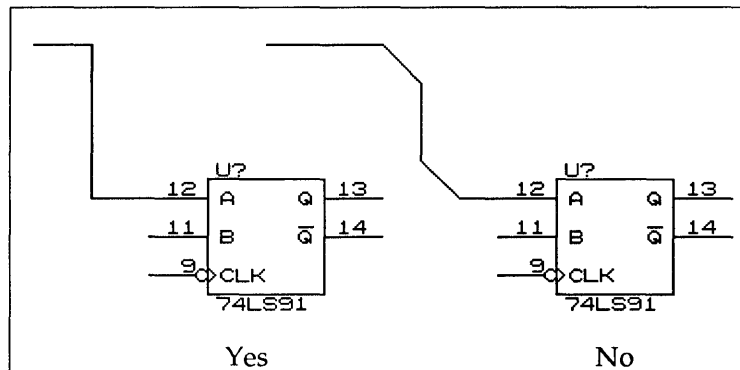

As the above figure shows, when you select **Orthogonal**, you then choose between **Yes** and **No**. **Yes** restricts wires and buses to connections at 90° angles; **No** places no restrictions on the angles and so you can draw wires and buses at any angle.

**SET Show Pin Numbers**

When **Show Pin Numbers** is turned on, pin numbers for library parts are shown on the screen and in worksheet hardcopies. When disabled, pin numbers are not shown on the screen or in hardcopies.

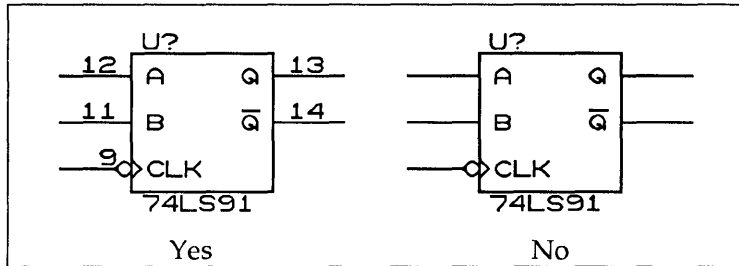

After you select **Show Pin Numbers**, you then choose between **Yes** and **No**. As the figure above shows, **Yes** turns on the display of pin numbers; **No** turns it off.

**SET Title Block**

When **Title Block** is turned on, **Draft** puts the standard title block on the worksheet. With the option turned off, you may create a custom title block using the **PLACE Wire/Bus** and **PLACE Text** commands.

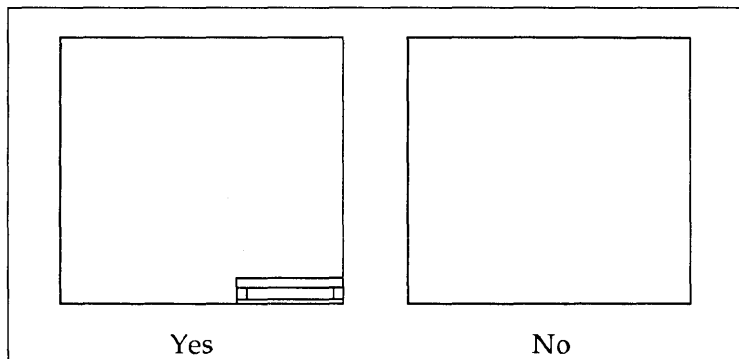

When you select **Title Block**, you then choose between **Yes** and **No**. **Yes** turns on the display of the title block; **No** turns it off.

**SET Worksheet Size** Use **Worksheet Size** to select the worksheet size, A through E.

After you select **Worksheet Size**, choose a letter from A through E. The exact dimensions of each worksheet size are defined in the **Template Table** on the **Configure Schematic Design Tools** screen. For more information, see *Chapter 1: Configure Schematic Tools*.

**SET X,Y Display** When **X,Y Display** is turned on, the upper right part of the prompt line shows the pointer coordinates. The worksheet origin (0,0) is the upper left corner. Coordinates do not appear on the screen until the pointer is moved.

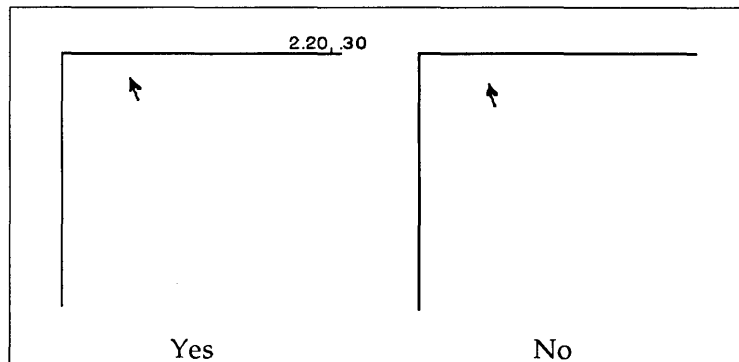

When you select **X,Y Display**, you then choose between **Yes** and **No**. **Yes** displays pointer coordinates; **No** doesn't.

- ▲ **CAUTION:** When grid coordinates are not displayed, it is easy to make small errors when placing parts, wires, and buses. These errors may cause problems when using the **Check Electrical Rules** reporter and **Create Netlist** processor. This is because wires and buses may look as if they are connected when they are not. **Check Electrical Rules** and **Create Netlist** interprets these incomplete connections as opens. Do not place parts, wires, or buses in the worksheet with **X,Y Display** disabled or with **Stay on Grid** turned off (described on the next page).

**SET Grid Parameters**

Select **Grid Parameters**. **Draft** displays the menu shown at right. Use **Grid Parameters** to display grid references, keep the pointer on grid, and display grid dots.

Set Grid Parameters

|                   |     |
|-------------------|-----|
| Grid References   | NO  |
| Stay on Grid      | YES |
| Visible Grid Dots | NO  |

*Grid References*

When **Grid References** are turned on, **Draft** displays an alphanumeric border on two of the four worksheet sides. The top border shows grid reference numbers, and the left border shows reference letters. The borders are scaled to the size of the worksheet. Grid references can be used as destination for the **JUMP** command.

*Stay on Grid*

When **Stay on Grid** is turned on, the pointer location is confined to the predefined grid. When disabled, the pointer may be moved off-grid to any position on the worksheet at a resolution ten times that of the grid.

After you select **Stay on Grid**, you select either **Yes** or **No**. **Yes** restricts the pointer to the grid; **No** does not.



**CAUTION:** *Placing parts, wires, and buses with **Stay on Grid** turned off may cause problems, because wires and buses may look as if they are connected when they are not. Unconnected wires and buses are reported as errors by the **Check Electrical Rules** reporter and **Create Netlist** processor. To avoid trouble, do not place parts, wires, or buses in the worksheet with **Stay on Grid** turned off.*

*Visible Grid Dots*

When **Visible Grid Dots** are turned on, grid dots display on the worksheet. When grid dots are visible and **SET Stay on Grid** is turned on, it is easier to place parts at specific points on the worksheet.

The distance between grid dots depends on the current zoom scale. The table at right lists the grid dot spacing at different zoom scales.

| Zoom scale | Grid dot spacing                 |
|------------|----------------------------------|
| 1          | $\frac{1}{10}$ of an X or Y unit |
| 2          | $\frac{2}{10}$ of an X or Y unit |
| 5          | $\frac{1}{2}$ of an X or Y unit  |
| 10         | 1 X or Y unit                    |
| 20         | 2 X or Y units                   |

After you select **Visible Grid Dots**, you select either **Yes** or **No**. **Yes** displays grid dots; **No** does not.

## SET Repeat Parameters

**Repeat Parameters** are used to determine how the **REPEAT** command works.

Select **Repeat Parameters**.

**Draft** displays the menu shown above.

### Set Repeat Parameters

|                      |     |
|----------------------|-----|
| X Repeat Step        | 0   |
| Y Repeat Step        | + 1 |
| Label Repeat Delta   | + 1 |
| Auto Increment Place | NO  |

### *X Repeat Step*

**X Repeat Step** determines the number of unit steps in the X direction the object being repeated is offset from the original object. The X direction goes horizontally across the worksheet, with positive to the right and negative to the left of the current pointer position. A unit step in the X direction is defined as  $\frac{1}{10}$  of an X unit when **SET Stay on Grid** is turned on and  $\frac{1}{100}$  of an X unit when **SET Stay on Grid** is turned off. You can view the change in X units as the pointer moves on the display by turning on the **SET X,Y Display** option.

When you select **X Repeat Step**, the prompt "X Repeat Step?" displays. Enter any integer.

### *Y Repeat Step*

**Y Repeat Step** determines the number of unit steps in the Y direction the repeated object is offset from the original object. The Y direction goes vertically on the worksheet, with positive above and negative below the current pointer position. A unit step in the Y direction is defined as  $\frac{1}{10}$  of a Y unit when **SET Stay on Grid** is turned on and  $\frac{1}{100}$  of a Y unit when **SET Stay on Grid** is turned off. You can view the change in Y units as the pointer moves on the display by turning on the **SET X,Y Display** option.

When you select **Y Repeat Step**, the prompt "Y Repeat Step?" displays. Enter any integer.

*Label Repeat Delta*

**Label Repeat Delta** determines how much the numeric suffix information on labels, module ports, and text changes, and in what direction, when they are repeated.

When you select **Label Repeat Delta**, the prompt “Label Repeat Delta?” displays. Enter a whole number. If you enter a positive number, the numeric suffixes on labels, module ports, and text are incremented by that number when they are placed with the **PLACE** command or the **REPEAT** command. If you enter a negative number, label suffixes are decremented by that number when placed with the **PLACE** command or the **REPEAT** command.

*Auto Increment Place*

When **Auto Increment Place** is turned on, the numeric suffix (if it exists) of labels, module ports, and text is automatically incremented or decremented when the objects are placed on the worksheet with the **PLACE** command. After a label, module port, or text string is placed, its numeric suffix is changed by the amount specified by the **Label Repeat Delta** command.

When you select **Auto Increment Place**, you then choose between **Yes** and **No**. **Yes** turns on automatic incrementing or decrementing of labels, module ports, and text; **No** turns it off.

**SET Visible Lettering**

You can choose to have some items on the worksheet display in zoom scale 2. When you select **Visible Lettering**, the menu shown at right displays.

To make an item visible, select it and choose **Yes**. To make it invisible, select it and choose **No**.

This option only affects how the lettering of the object appears on the screen in zoom scale 2.

Visible lettering for Scale 2

|             |     |
|-------------|-----|
| Part Field  | YES |
| Pin Number  | NO  |
| Pin Name    | NO  |
| Label       | NO  |
| Text        | YES |
| Module Port | NO  |
| Power Value | YES |
| Sheet Name  | YES |
| Sheet Net   | NO  |
| Title Block | YES |

---

**TAG**

The **TAG** command identifies and remembers locations on the worksheet. You can specify eight locations (A through H) using the pointer. Tagged locations can be used as destinations for the **JUMP** command. Tags are invisible when set on the worksheet and are not saved with the worksheet.

Tag set

|   |     |
|---|-----|
| A | Tag |
| B | Tag |
| C | Tag |
| D | Tag |
| E | Tag |
| F | Tag |
| G | Tag |
| H | Tag |

To set a tag, place the pointer at a location you want to remember. Then select the **TAG** command. **Draft** displays the menu shown above.

When the **TAG** menu displays, select the tag to set from the menu. Once selected, **Draft** remembers the tag location. Once the tag is set, **Draft** returns to the main menu level.



## ZOOM

**ZOOM** zooms in or out from the worksheet, changing the amount of detail you see on the screen. You can select from the five zoom levels described below.

**Scale 1** The most detailed zoom scale. All lettering is visible.

**Scale 2** The second most detailed zoom scale, representing  $\frac{1}{2}$  of scale 1.

**Scale 5** The third most detailed zoom scale, representing  $\frac{1}{5}$  of scale 1.

**Scale 10** The fourth most detailed zoom scale, representing  $\frac{1}{10}$  of scale 1.

**Scale 20** The least detailed zoom scale, representing  $\frac{1}{20}$  of scale 1.

To change the zoom scale, select **ZOOM**. **Draft** displays the menu shown at right.

Zoom (present scale= 2)

|        |     |
|--------|-----|
| Center | (1) |
| In     | (1) |
| Out    | (2) |
| Select |     |

### ZOOM Center

Selecting **ZOOM Center** centers the displayed portion of the sheet around the pointer. This command is useful for centering an object on the screen so you can easily edit it.

For example, if the display of an object is partially off the screen, center it by placing the pointer near the object and selecting **ZOOM Center**.

The number in parentheses shows the current zoom scale.

### ZOOM In

**ZOOM In** zooms in on the worksheet for a more detailed view. The number in parentheses shows what the zoom scale will be the next time you select **ZOOM In**.

### ZOOM Out

**ZOOM Out** zooms out to display a larger worksheet area. The number in parentheses shows what the zoom scale will be the next time you select **ZOOM Out**.

### ZOOM Select

Use **ZOOM Select** to select any one of five zoom scales (1, 2, 5, 10, or 20) from a menu.



## *Guidelines for creating designs*

This chapter is intended to help you automatically create netlists from your schematics. To obtain predictable results, several simple rules need to be followed. When the rules are followed, you can use the **Create Netlist** and the **Create Hierarchical Netlist** processors to create netlists in over thirty formats. If you plan to use your schematics with any of OrCAD's other tools, such as **PC Board Layout Tools**, following these rules greatly simplifies the task of creating a usable netlist.

If these rules are not followed, the database that contains the connectivity of all of the components may contain incorrect connections.

---

### **Label names**

**Draft** is quite liberal concerning label names: it accepts any of the standard ASCII printable characters in naming labels and buses. Some netlist formats are more restrictive. You should be aware of any naming restrictions imposed by your target netlist format. For instance, **PC Board Layout Tools** does not allow spaces, left parentheses or braces, or right parentheses or braces.

### **Wire labels**

Use labels to connect signals from one worksheet area to another without using wires or buses.

For example, assume you have a signal labeled ABC in your worksheet and you would like to connect another object on the worksheet to the same signal. Instead of drawing a wire from ABC on one side of the worksheet to the other object, you can identify each signal with a label, as shown in figure 3-1.

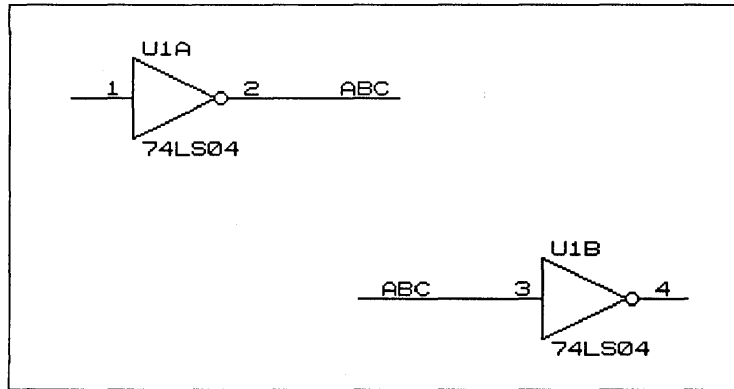

Figure 3-1. Using a label.

### Bus labels

Labels are also used for naming buses and bus members. For **Create Netlist** and **Create Hierarchical Netlist** to properly associate a bus with its individual members, both the bus and the wires (bus members) branching from the bus *must* be labeled following a specific format.

Bus labels must be in the form:

BUSNAME[x..y]

The *prefix* of the label, indicated above by BUSNAME, represents the name of the bus. The *suffix* of the label, indicated above by [x..y], specifies a range of decimal integers representing the number of wires branching from the bus. *x* represents the first wire number in the bus; *y* represents the number of the last wire branching from the bus. *y* must be greater than or equal to *x*. There will be  $(y - x + 1)$  wires in the bus. The prefix and suffix must not have spaces between them.

Examples are:

|               |                            |
|---------------|----------------------------|
| ADDR[0..31]   | (This bus has 32 members.) |
| DATA[16..31]  | (This bus has 16 members.) |
| CONTROL[1..4] | (This bus has 4 members.)  |
| A[100..190]   | (This bus has 91 members.) |

Figure 3-2 shows a bus label properly positioned.

A bus label may be placed anywhere on the bus, as long as the label's hotpoint is touching the bus. See the **PLACE Label** command in *Chapter 2: Draft* for a description of label hotpoints. A bus may have more than one label placed on it.

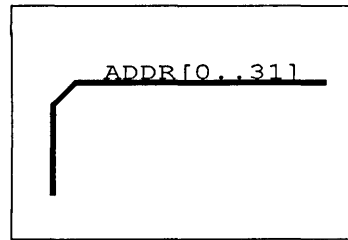

Figure 3-2. Correct position for a bus label.

Wires branching from a bus must be labeled in a form corresponding to the bus. For example, suppose a bus is labeled as follows:

BUSNAME [0..9]

Then the wires branching from the bus must have labels of the form shown below:

BUSNAME $x$

where  $x$  is a decimal integer in the range of 0–9. BUSNAME and  $x$  must not have space between them.

Figure 3-3 shows an example of a properly labeled bus and its members.

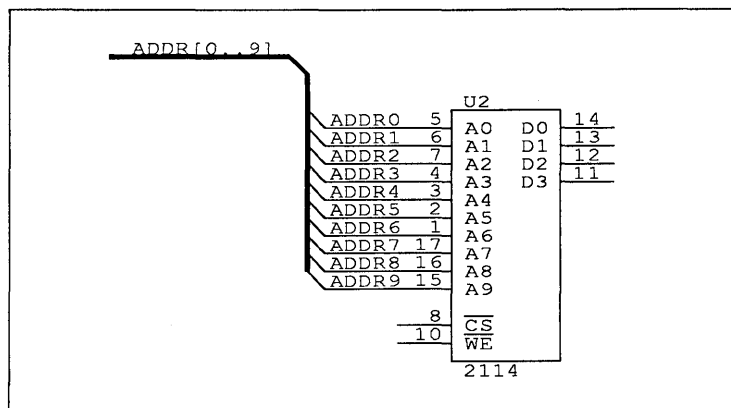

Figure 3-3. Label format required by *Create Netlist* and *Create Hierarchical Netlist* for buses and bus members.

**Multiple labels on a bus**

A bus may have more than one label placed on it. In actual applications, bus labels may be placed anywhere on the bus and still be associated with their respective bus signal labels. As a rule, you may place any number of labels on a bus or wire. However, only the busname in the form:

BUSNAME [x..y]

will be used for the netname. The other labels are strictly for your convenience. They are not used in netlists.

**Combining labels**

Often times it is necessary to refer to bus members by names other than that of the bus. For instance, one member of a bus might be MEM10, but you still want to refer to it as C\S\ (this notation represents CS with a bar over it, meaning the complement of CS). This is an example of combining labels. Figure 3-4 shows label MEM[0..11] as a bus containing 12 members. U1 is connected to the bus via labels MEM0 through MEM11.

Notice on the left side of the figure that label MEM10 has label C\S\ placed next to it, and that label MEM11 has label W\E\ next to it. On the other side of the figure, C\S\ and W\E\ are labels that have been placed on pins 8 and 10 of U2 and U3.

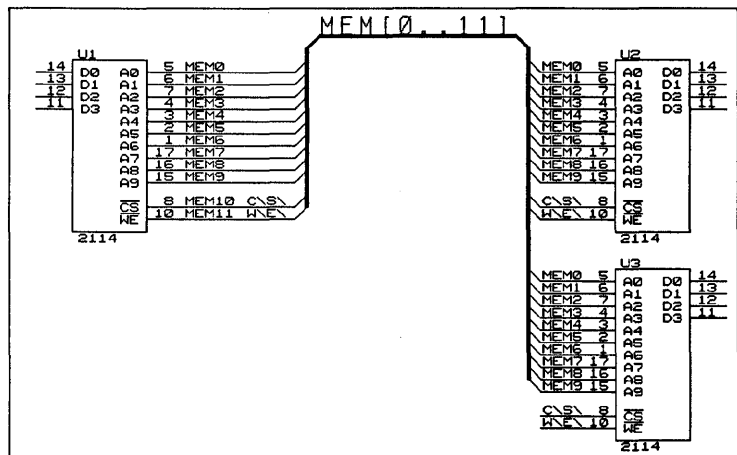

Figure 3-4. Combining labels.

This example shows how to connect signals MEM10 and MEM11 to U2, by labeling them as C\S\ and W\E\, respectively. In the case of U3, C\S\ and W\E\ signals are connected to the 2114 device without being physically connected to the bus.

## Intersheet connections

For the netlist processors to list inter-worksheet connections properly, they must be specified on the worksheets following certain conventions.

Lateral inter-sheet connections, as in flat file structures, are established by placing complementary module ports with the same names on different sheets.

Vertical inter-sheet connections, as in hierarchical designs, are established by placing module ports having the same names as nets placed in a sheet symbol one level up in the hierarchy.

When buses connect to module ports or nets, the bus-range format explained in the previous section must be used in both module port names and net names. The ranges specified in module port and net names must match the ranges of the buses to which they connect.

The *prefix* of a module port name or net name need not be identical to the prefix of the label on the bus to which it connects. However, making them the same is a good practice, unless there is a reason for doing otherwise.

Figure 3-5 shows three examples of buses properly connected to module ports. Notice the bus label suffix, [0..15], is identical to the module port suffix.

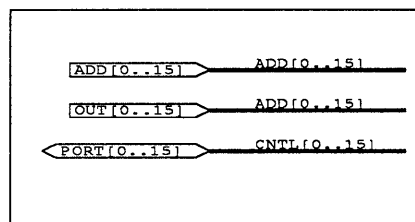

Figure 3-5. Connecting buses to module ports.

Figure 3-6 shows a more detailed example of connecting bus signals to module ports.

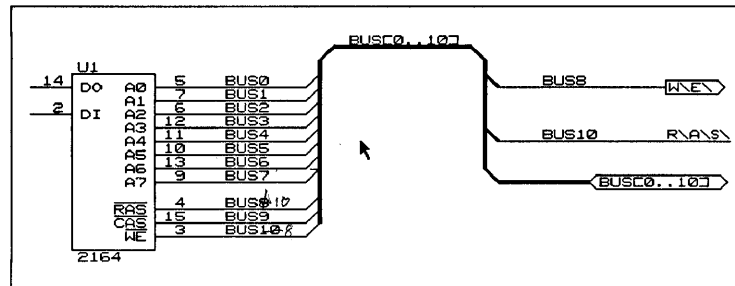

Figure 3-6. Connecting buses to module ports.

The main bus in figure 3-6 is labeled BUS[0..10]. Electrical connection between the wires branching from this bus and component U1 is established by labeling the wires BUS0 through BUS10.

The signal labeled BUS8 is conducted off the worksheet through the module port named W\E\. The wire label for this signal is based on the format of the bus label. But, as shown, the name of the module port on this wire does not have to match the wire label. However, to establish connection with a module port on some other worksheet, the other module port must also be named W\E\.

The bus BUS[0..10] also leaves the worksheet. It connects to a module port having the same name. While the prefix, BUS, *could* legally be different, the suffix specifying the number of signals must be identical.

The signal labeled R\A\S\ can be connected to a wire elsewhere in the worksheet simply by giving the other wire the same label. Because the R\A\S\ signal is transferred through the bus, BUS[0..10], it must also have a label based on the format of the bus label; in this case, BUS10.

Module ports connected to individual, non-bus wires may be named in any format. They are not required to have a suffix. Figure 3-7 shows typical examples of non-bus signals connected to module ports.

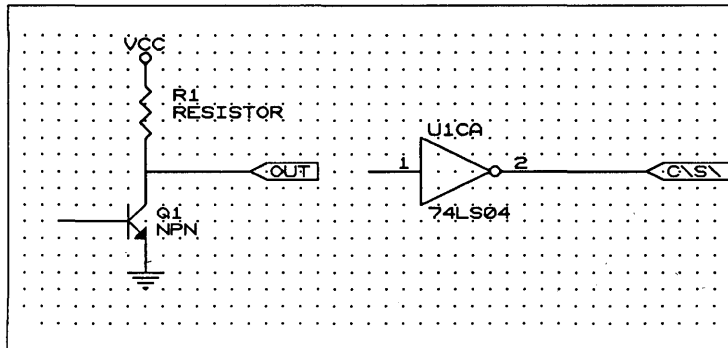

Figure 3-7 Module ports connected to non-bus signals.

△ **NOTE:** It is not necessary to place the label `BUS[0..10]` on the bus since the module port `BUS [0..10]` is on the bus. At every module port, a label with the same name is assigned when the connectivity database is constructed.

## Splitting buses

You can split buses in your worksheet. Figure 3-8 shows an example.

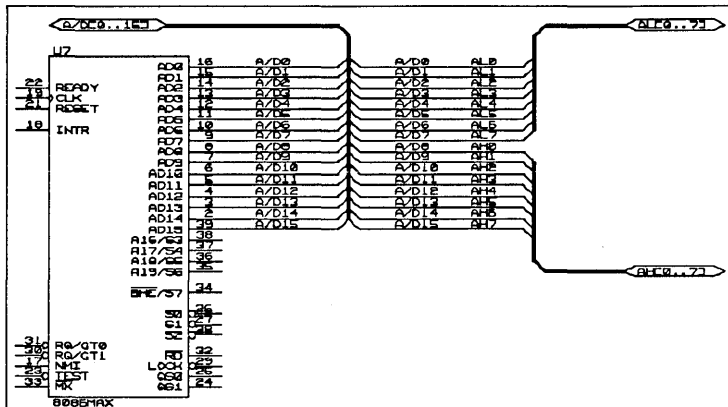

Figure 3-8 Splitting a bus.

As shown in figure 3-8, you can split the same signal off a bus multiple times by attaching more than one wire with the same label.



## Handling and isolating power

Power connections are handled in a number of ways. Most parts in the libraries supplied by OrCAD have defined power and ground pins. These pins are hidden from the drawing, but nonetheless are part of the symbol definition.

To make connections from the outside world to the hidden power pins in the library part, **Draft** uses a *power object* (placed with the **Place Power** command).

For example, assume you have a CMOS device placed in the worksheet. In the CMOS library source file, this device is defined to have a VDD and VSS power pin. To connect another signal from the outside world to the same VDD potential as in the CMOS device, just connect the signal to a power object named VDD.

Power objects are *global* in scope. A global object is one whose signal (power in this case) connects to all other global signals of the same name. Connectivity between global objects of the same name holds for all worksheet file structures.

The programs that build the connectivity database connect all power objects and signals of the same name. This power handling ability makes it easy to isolate different power sources.

These programs also treat certain parts in part libraries as power objects if they are defined a special way. The four types of grounds in the DEVICE.LIB library (Earth, Field, Power, and Signal grounds) are good examples.

→ To be treated as a power object, a device is defined as having zero parts per package, only one pin and no reference designator. The pin is defined to be of type PWR. Figure 3-9 shows the source file definition of the GND POWER symbol found in the DEVICE.LIB part library. Significant entries appear in bold. When a part has these characteristics, **Draft** treats the part from the library as a power object.

```
'GND POWER'
{X Size =}2 {Y Size =}1 Parts per Package =}0 T1 PWR 'GND'
  {0000000001111111112}
  {.....}
  {012345678901234567890}
{ 0.0}#####
{ 0.1}.....
{ 0.2}.....
{ 0.3}...#####...
{ 0.4}.....
{ 0.5}.....
{ 0.6}.....#####.....
{ 0.7}.....
{ 0.8}.....
{ 0.9}.....###.....
{ 1.0}.....

VECTOR
LINE   +0.0 +0.0 +2.0 +0.0
LINE   +0.3 +0.3 +1.7 +0.3
LINE   +1.4 +0.6 +0.6 +0.6
LINE   +0.9 +0.9 +1.1 +0.9
END
```

Figure 3-9. Source file for the GND POWER symbol.

In the example in figure 3-9, notice the pin name is GND. If this power ground symbol is placed on a worksheet, it represents it as being connected to any other object with a power pin named GND.

There are several ways to create different power supplies in a design. One way is to simply place a power object on the worksheet with the **Place Power** command, select the **Value** command and change the value to be whatever you want to distinguish it from other power objects.

Another approach is to create a custom power object and give its pin a unique name using the OrCAD part library editor, **Edit Library**.

Or, edit the definition of a power object in a library source file and give its pin a unique name. Then, update the binary form of the library by running the **Compile Library** tool.

For example, in the part library source file, you could edit the signal ground definition, changing the name of its pin from GND to SGND. Or, you could edit the power ground definition, and change its pin name from GND to PGND. Each type of ground will then be connected to any other object with a power pin defined as SGND or PGND.

To find power pin numbers on library components, use the **LIBRARY Browse** command in **Draft** or **Edit Library**.

**Connecting power objects with different names**

In OrCAD libraries, many of the devices are defined with the positive supply voltage pin named VCC. Others are defined with the positive supply voltage pin named VDD. To operate pins of both types from the same power supply, you must connect those pins to one another.

Similarly, many of the libraries have return power pins defined as GND or as VSS. The same requirement applies for connecting both types to the same potential.

To connect power supply pins together, or connect a power supply pin to any other supply voltage, you place a separate power object for each different supply in the worksheet. Name one power object with the same name as one of the supply voltages, VDD for example. Name the other power object with the same as the remaining supply voltage, VCC for example. Finally, connect the two power objects together with a wire. The following figure shows how this is accomplished.

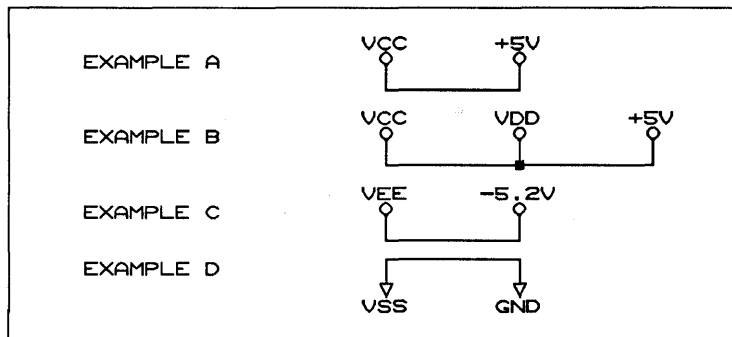

Figure 3-10. Power supply connections.

Example A shows a power object named VCC connected to a +5 volt power supply. In the connectivity database, every object with a VCC pin is connected to a +5 volt power supply. This assumes your design contains a power supply with a power object named +5V attached.

Example B shows two power objects, VCC and VDD, connected to a +5 volt power supply through a power object named +5V.

Example C shows a power object, VEE, connected to a -5.2 volt power supply through a power object named -5.2V.

Example D shows a power object, VSS, connected to a power object named GND. This electrically connects the two types of grounds in the net list.

### Connecting power objects to a module port

One way to isolate power in the worksheet is to edit parts in the source library file, giving their power pins new names, then update the library with **Compile Library**. This is time consuming and makes it difficult to keep track of which parts are to be used on which schematic for any particular supply. There is, however, another way to isolate power.

To isolate power without editing the part libraries, connect a module port to a power object. When the connectivity database is built, the name of the module port supersedes the library name of the power object. Only the module port name is used in conducting the power signal from one worksheet to another.

If a power object is to transfer isolated power from one worksheet to another, either in a linked file or hierarchical structure, it must be connected to a module port of type **Unspecified**. The **Check Electrical Rules** step in **Create Netlist** does not accept other types of module ports.

Figure 3-11 shows three examples of power objects connected to module ports.

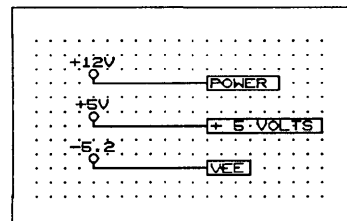

Figure 3-11. Isolating power on a worksheet by connecting power objects to module ports.

**Handling power in a hierarchy**

Power in a hierarchy is handled in much the same way as it is in a linked file design. Power objects connect to all other objects with the same name. If a module port is connected to a power object, the module port supersedes the power object for conducting the signal off the worksheet.

When passing power from a worksheet through a module port up to a sheet symbol, you must place a sheet net in the sheet symbol to conduct the power signal.

**Example of isolating power: battery backup**

In battery backup applications, main power can be supplied throughout the design with power objects. Backup power can be isolated from the main source by using a module port. Figures 3-12 through 3-14 show this approach to a battery backup application.

This design is a three-sheet hierarchy. The root sheet, shown in figure 3-12, contains the CPU and control circuitry of the design. Two sheet symbols are also placed in the root worksheet. One sheet symbol represents the power supply; the other represents the memory backed up by battery.

Notice a VDD power object is placed in the root worksheet and connects to a +5V power object. Since the 80C51 and the 82C82 power pins are labeled as VDD in their library source files, the +5V and VDD power objects connect +5 volts from the power supply (shown in figure 3-13) to the VDD pins of both devices.

Figure 3-14 shows the battery backed CMOS memory. The memory control signals are conducted from the CPU root sheet through module ports AD[0..7], WE, and A[0..7]. In the POWER SUPPLY worksheet, the power signal to the CMOS MEMORY worksheet is isolated from the +5V supply through a module port named BACKUP.

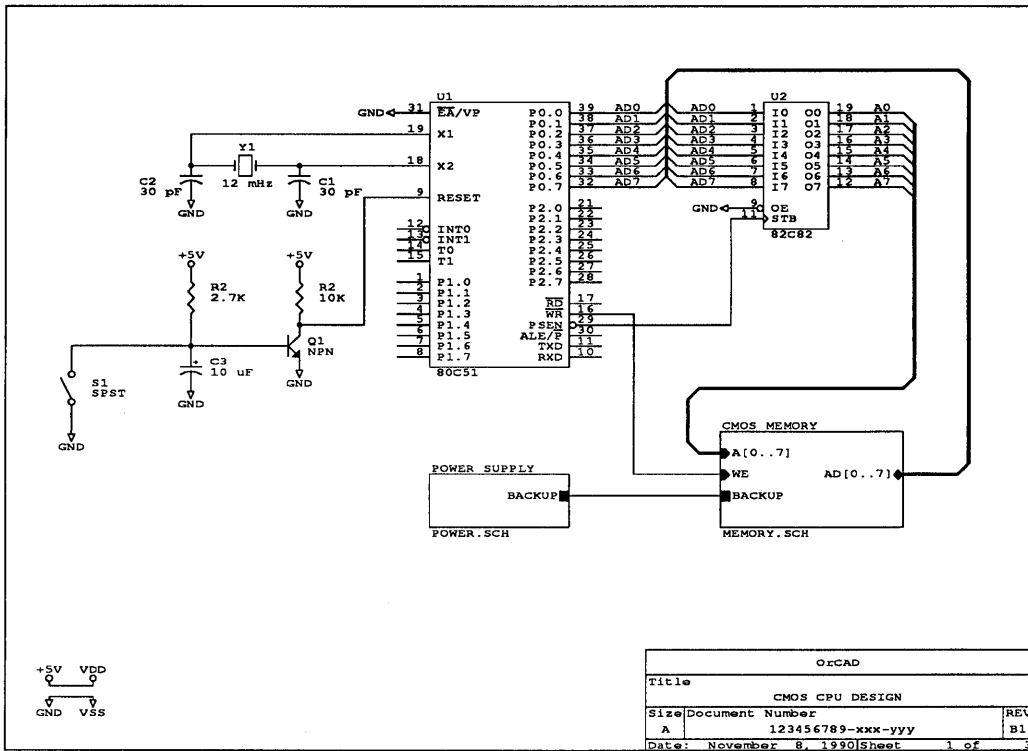

Figure 3-12. Root CPU sheet.

In the CMOS MEMORY sheet (figure 3-14), another module port named BACKUP connects to a power object named VDD, isolating VDD on this sheet from VDD on all of the other sheets.

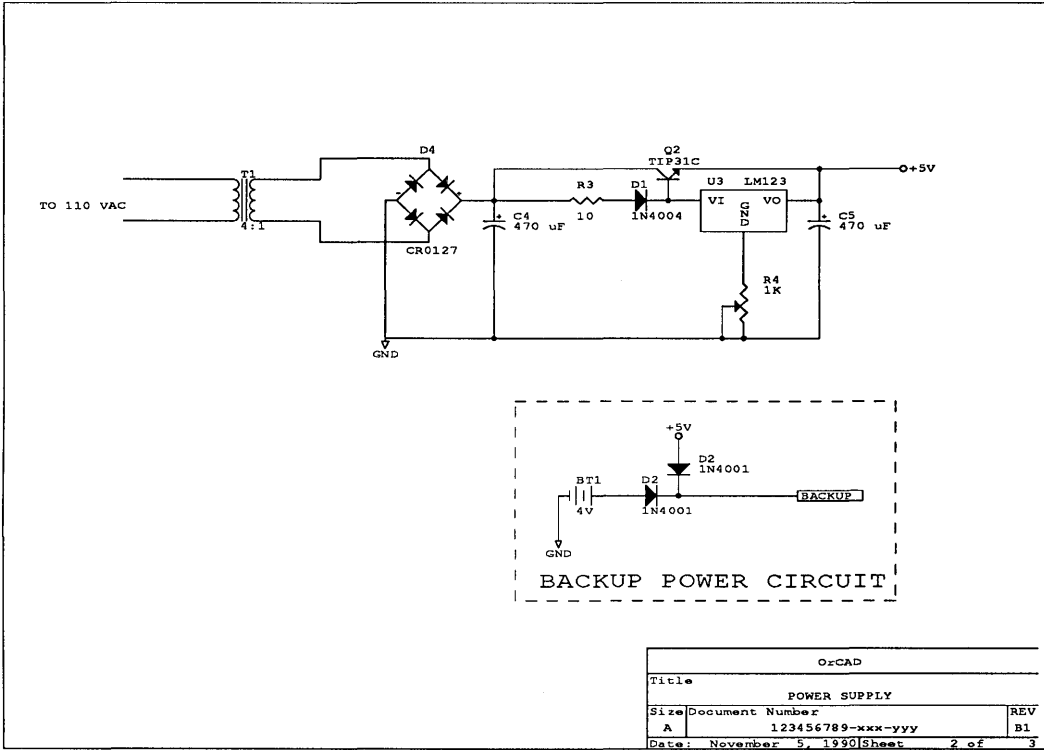

Figure 3-13. Power supply sheet.

GND and VSS power objects are also placed in the CMOS MEMORY worksheet. This connects the VSS power return pins from the memory devices to the Power Ground object.

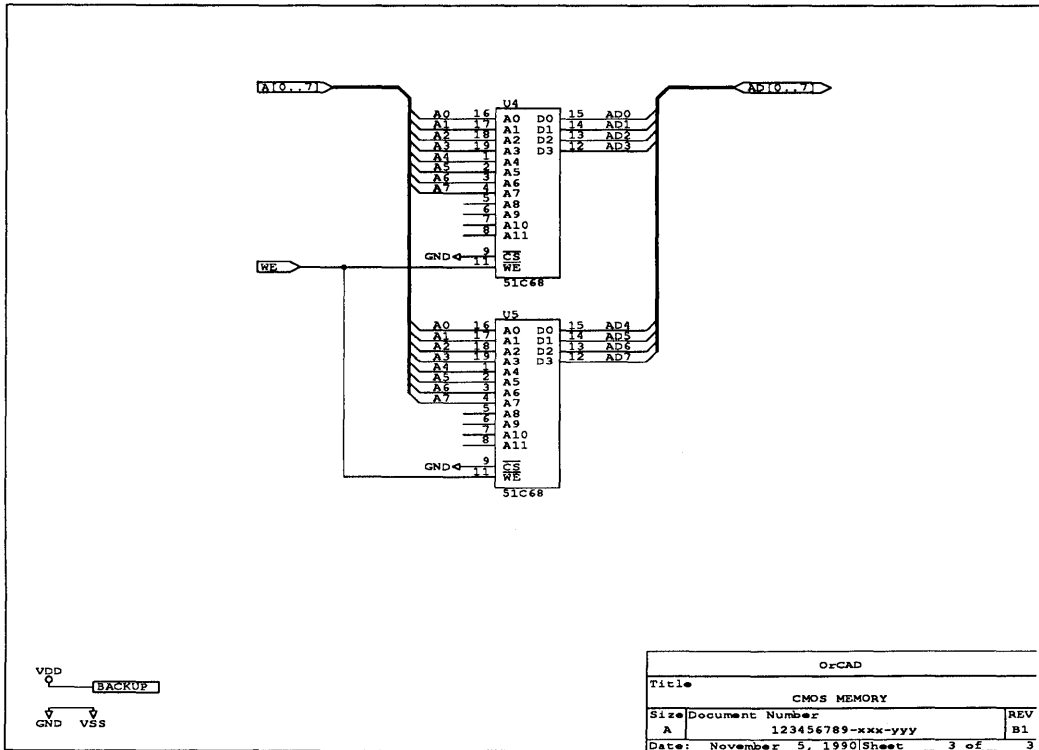

Figure 3-14. CMOS memory sheet.

To summarize, isolate power in a design by conducting it through module ports connected to power objects selectively named to match the names of power pins in library source files.

Although this example design is a hierarchy, it could have been created as a flat file structure. In applications where you isolate power, place all of the circuitry to be isolated in a separate worksheet. This keeps isolated power specific to one worksheet.



## Handling physical connectors

Module ports are not intended to be used as physical connectors in a design. Use module ports to connect signals from one worksheet to another. Physical connectors are library parts, since connectors require a reference designator and part value.

To make schematics easier to read, don't separate individual pins in a connector and place them all over the worksheet. This makes finding connector pins difficult, especially in multiple sheet designs. Instead, place a connector on one worksheet and use module ports or labels to connect its pins to other signals in the design. Figure 3-15 shows an example.

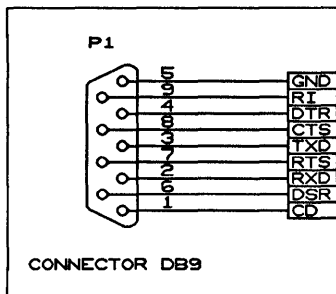

Figure 3-15. Handling connectors.

Make large connectors with alphanumeric pin names using a block symbol with zero parts per package .

Figure 3-16 shows part of a library source file definition for an IBM PC 62-pin edge connector. Because of its large size, only part is shown. Since there are no pin numbers defined in the source file, Create Netlist will use pin names instead to identify the pins when it builds the connectivity database. In this definition, B1-B31 and A1-A31 are the pins on the 62-pin edge connector.

```
'CONNECTOR IBM'
REFERENCE 'J'
10 32 0
L1 PAS 'B1'
L2 PAS 'B2'
L3 PAS 'B3'
L4 PAS 'B4'
.
.
L30 PAS 'B30'
L31 PAS 'B31'
R1 PAS 'A1'
R2 PAS 'A2'
R3 PAS 'A3'
R4 PAS 'A4'
.
.
R30 PAS 'A30'
R31 PAS 'A31'
```

Figure 3-16. Source file for an IBM 62-pin edge connector.



## *Edit File*

---

### About Edit File

The **Edit File** button runs a text editor. When you receive your ESP software from OrCAD, it is configured to run a text editor called M2EDIT. However, you can configure ESP to run the text editor of your choice.

For instructions on how to configure ESP to run your text editor, see the *ORCAD/ESP Design Environment User's Guide*. To use the M2EDIT editor, see the *Stony Brook M2EDIT Text Editor User's Guide*.

---

### Execution

With the **Schematic Design Tools** screen displayed, select **Edit File**. Select **Execute** from the menu that displays. The screen for the configured text editor displays.





## *View Reference*

---

### About View Reference

The **View Reference** button runs a text editor in a reference material directory provided by OrCAD. This directory contains supplemental “read me” files of product information. These files contain information such as:

- ❖ List of drivers supported by ESP
- ❖ List of drivers that can be made using GENDRIVE
- ❖ List of parts found in each library

When you receive your ESP software from OrCAD, it is configured to run a text editor called M2EDIT. However, you can configure ESP to run the text editor of your choice.

For instructions on how to configure **ESP** to run your text editor, see the *OrCAD/ESP Design Environment User's Guide*. To use the M2EDIT editor, see the *Stony Brook M2EDIT Text Editor User's Guide*.

---

### Execution

With the **Schematic Design Tools** screen displayed, select **View Reference**. Select **Execute** from the menu that displays. Select **Execute**. The screen for the configured text editor displays. Use the text editor to open and read the reference file of your choice.



**Schematic Design Tools** includes seven Processors that read, modify, and then rewrite the design database. Processors generally do not create human-readable reports, but rather create or modify database information.

Part III describes Processor tools and provides instructions for their use.

- Chapter 6:* *Annotate Schematic* describes how **Annotate Schematic** scans a design and automatically updates the reference designators of all parts in the worksheet.
- Chapter 7:* *Back Annotate* describes how **Back Annotate** scans a design and updates part reference designators according to the instructions you provide in a "Was/Is" file.
- Chapter 8:* *Cleanup Schematic* describes how **Cleanup Schematic** scans a design and checks for wires, buses, junctions, labels, module ports, and other objects that are placed on top of each other.
- Chapter 9:* *Creating a netlist* gives an overall description of incremental netlisting.
- Chapter 10:* *Create Netlist* describes how to create a linked and flattened netlist.
- Chapter 11:* *Create Hierarchical Netlist* describes how to create a hierarchically formatted netlist.
- Chapter 12:* *Select Field View* describes how to use **Select Field View** to change visible attributes of specified fields on a worksheet.
- Chapter 13:* *Update Field Contents* describes how to use **Update Field Contents** to load user-defined information into the fields of parts on a worksheet.





## *Annotate Schematic*

---

### Execution

The **Annotate Schematic** processor scans a design and automatically updates the reference designators of all parts in the worksheet. This includes updating the corresponding pin numbers (associated with a particular instance of a part) with multiple devices in the package.

**Annotate Schematic** updates reference designators in the order the parts were placed in the worksheet. When the worksheet is annotated, all parts may be assigned a new reference designator, including any manually edited parts. To selectively change reference designators and leave others unmodified, use the **Back Annotate** tool or **Draft**.

### Running Annotate Schematic

With the **Schematic Design Tools** screen displayed, select **Annotate Schematic**. Select **Execute** from the menu that displays.

While **Annotate Schematic** runs, messages display on the screen. When the annotation is complete, the **Schematic Design Tools** screen displays.



**Key fields** **Annotate Schematic** has one key field. It is shown on the **Key Fields** area on the **Configure Schematic Design Tools** screen as follows:

ANNOTATE Part Value Combine

This key field determines how **Annotate Schematic** will group parts in devices that have multiple parts per package. If the parts have empty key fields and matching part values, **Annotate Schematic** assigns parts to the same package. If the parts have data in their key fields, **Annotate Schematic** assigns parts to the same package only if their key fields match. For this reason, if you use the **Annotate Schematic** key field, you should include the part value as part of the key field.

For more about key fields, see *Chapter 1: Configure Schematic Tools*.

**Before annotation and after annotation**

Figure 6-1 illustrates a worksheet that is not annotated. Figure 6-2 shows the same worksheet, after annotation.

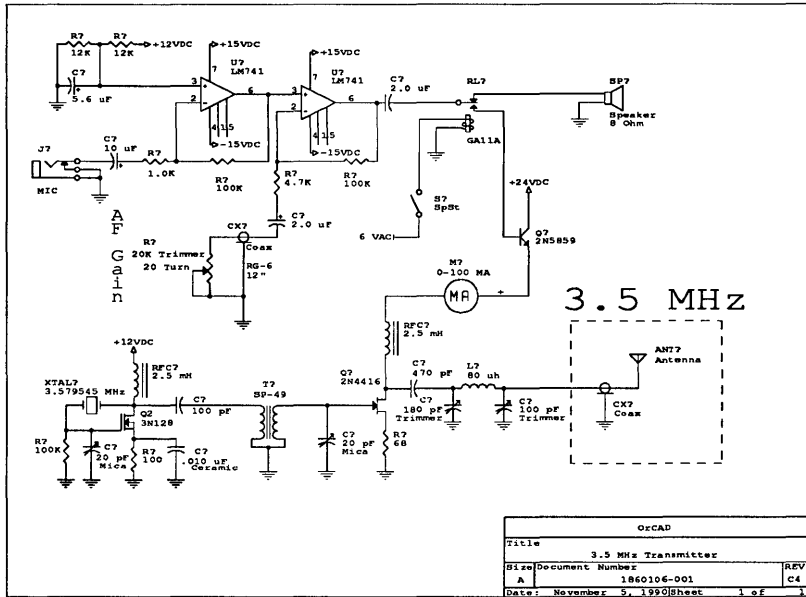

Figure 6-1. Worksheet before annotation.

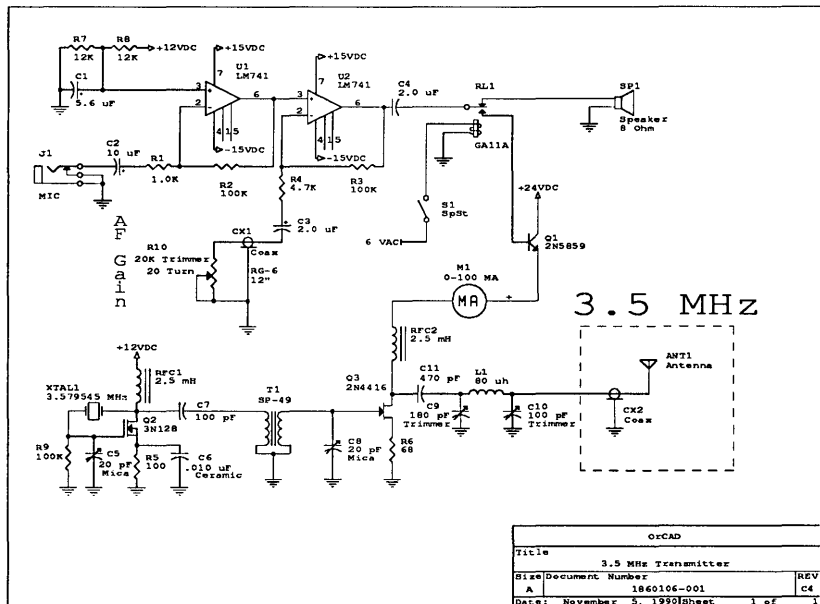

Figure 6-2. Annotated worksheet.

## Local Configuration

With the **Schematic Design Tools** screen displayed, select **Annotate Schematic**. Select **Local Configuration** from the menu that displays.

Select **Configure ANNOTATE**. A configuration screen appears (figure 6-3).

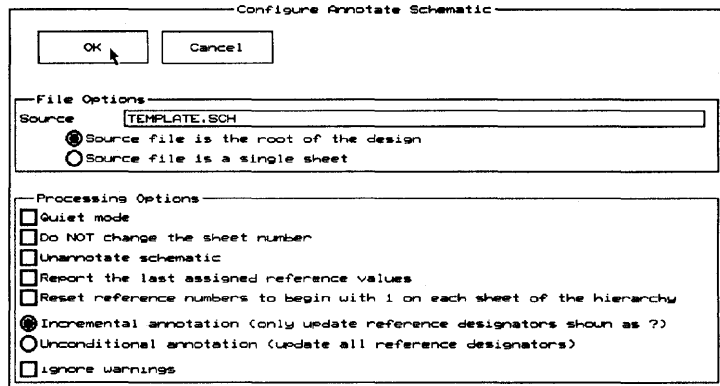

Figure 6-3. Annotate Schematic's local configuration screen.

**File Options** File Options defines the source file and its type.

*Source* The **Source** is the root of the design or the filename of a single sheet. It may have any valid pathname.

After entering the source filename, select one of the following options:

- Source file is the root of the design  
Specifies that the source file is the root sheet name of a hierarchical or flat design. If the root sheet contains sheet symbols, then the design is hierarchical. If it contains a |Link, it is a flat design.
- Source file is a single sheet  
Specifies that the source file is a single worksheet and you want to process the single sheet only.

**Processing Options**

You may select any combination of the following options:

- Quiet mode  
Turns quiet mode on.
- Do NOT change the sheet number  
Causes the sheet number set in the title block to remain unchanged. If this option is not selected, **Annotate Schematic** renumbers all of the schematics in the design.
- Unannotate schematic  
Resets all reference designators in the design. When parts were first placed, the reference designator had a numeric component of "?". This option resets all number to "?".
- Report the last assigned reference values  
Tells **Annotate Schematic** to report the last reference designator assigned to a design, after it is done annotating. The report is placed in a file with the same name as the source, ending with the extension .END.
- Reset reference numbers to begin with 1 on each sheet of the hierarchy  
Restarts all reference designators used at 1 for each sheet of the design instead of only on the first sheet. Use this option to annotate a complex hierarchy. If you are using OrCAD's **Digital Simulation Tools** and your design is a complex hierarchy, this option is recommended.

Select one of the following options:

- Incremental annotation (only update reference designators shown as ?)

Updates only the reference designators that have a "?". When new parts are placed on a sheet, the reference is not assigned a numeric value, but rather is given the unassigned designation of "?". If you do not wish to renumber all reference designators, including all previously set references, use this option.

- Unconditional annotation (update all reference designators)

Updates all reference designators in the order in which they are placed in the worksheet. All references are updated, even those that may have been assigned previously.

If desired, select this option:

- Ignore warnings

Causes **Annotate Schematic** to continue running when it encounters warnings, instead of halting.



## *Back Annotate*

---

### Execution

**Back Annotate** scans a design or a single sheet and updates part reference designators. To run **Back Annotate**, you must provide a text file that lists old and new reference designators. This file is called a "Was/Is" file.

### Was/Is file format

A Was/Is file is a text file containing the old and new reference designators. You create it using a text editor.

A Was/Is entry begins with the old reference designator that you want to modify, followed by any number of space, tab, or new line characters, which is in turn followed by the new reference designator value. Make a Was/Is entry for each reference designator you want to change. A new line is not required after each entry.

The following is an example of a typical Was/Is file:

```
R1   R5
R2   R12
R3   R6
C5   C1
C12  C2
U5C  U1A
U3B  U3A
```

In the above example, the occurrence of R1 in the design is changed to R5, R2 becomes R12, and so on.

### Running Back Annotate

With the **Schematic Design Tools** screen displayed, select **Back Annotate**. Select **Execute** from the menu that displays.

When the reference designators are changed, the **Schematic Design Tools** screen displays.

## Local Configuration

With the Schematic Design Tools screen displayed, select **Back Annotate**. Select **Local Configuration** from the menu that displays.

Select **Configure BACKANNO**. A configuration screen displays (figure 7-1).

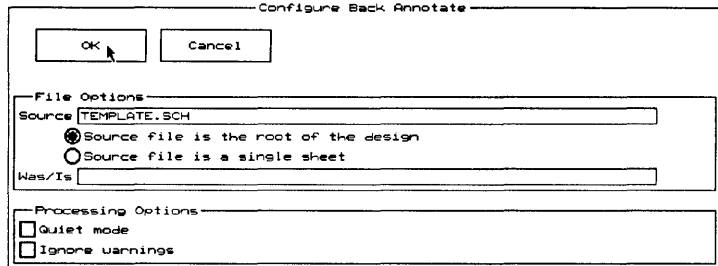

Figure 7-1. Back Annotate's local configuration screen.

### File Options

**File Options** defines the source file and its type, and the Was/Is file.

#### Source

The **Source** is the root of the design or the filename of a single sheet. It may have any valid pathname.

After entering the source filename, select one of the following options:

- Source file is the root of the design

Specifies that the source file is the root sheet name of a hierarchical or flat design. If the root sheet contains sheet symbols, then the design is hierarchical. If it contains a |Link, it is a flat design.

- Source file is a single sheet

Specifies that the source file is a single worksheet and you want to process the single sheet only.

#### Was/Is

**Was/Is** specifies the name of the text file containing the old and new reference designator pairs. It may have any valid path and name. The format of this file is discussed at the beginning of this chapter.

**Processing Options**    You may select any combination of the following options:

Quiet mode

Turns quiet mode on.

Ignore warnings

Causes **Back Annotate** to continue running when it encounters warnings, instead of halting.







## *Cleanup Schematic*

---

### Execution

**Cleanup Schematic** scans a file and checks for wires, buses, junctions, labels, module ports, and other objects that are placed on top of each other. It can scan an entire design or a single sheet.

**Cleanup Schematic** removes duplicate or overlapping wires, buses, and junctions, and displays warning messages advising you of other duplicate objects. It does not check for objects overlapping part leads, wires overlapping buses, or wire bus entries overlapping bus bus entries.

Use **Cleanup Schematic** whenever you want to check for and correct drawing errors in the worksheet. Check all worksheets with **Cleanup Schematic** to reduce errors and warnings that may occur when you use other utilities.

### Running Cleanup Schematic

With the **Schematic Design Tools** screen displayed, select **Cleanup Schematic**. Select **Execute** from the menu that displays.

When the schematic is “cleaned up,” the **Schematic Design Tools** screen displays.

When **Cleanup Schematic** processes a very large worksheet, the tool may display the message: “CLEANUP will need to be repeated for this file”. This means there was not enough memory to complete the cleanup process in one pass. If this occurs, run **Cleanup Schematic** again.

**Cleanup Schematic** renames the original schematic files (the files as they existed before **Cleanup Schematic** was run) with a .BAK extension. It saves the changed schematic files using the filenames of the original files.

If your disk becomes full during the cleanup operation, you will always have your original design intact. The original design is preserved because **Cleanup Schematic** does not rename the original file until after it has been successfully processed. After the process is complete, the original file is renamed to a .BAK extension and the processed version of the file is given the original name.

## Local Configuration

With the Schematic Design Tools screen displayed, select **Cleanup Schematic**. Select **Local Configuration** from this the menu that displays.

Select **Configure CLEANUP**. A configuration screen displays (figure 8-1).

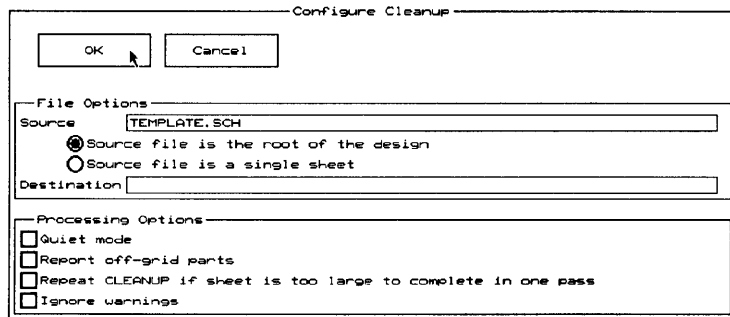

Figure 8-1. Cleanup Schematic's local configuration screen.

**File Options** File Options defines the source file and its type, and the destination file.

*Source* The **Source** is the root of the design or the filename of a single sheet. It may have any valid pathname.

After entering the source filename, select one of the following options:

- Source file is the root of a hierarchy  
Specifies that the source file is the root sheet name of a hierarchical or flat design. If the root sheet contains sheet symbols, then the design is hierarchical. If it contains a |Link, it is a flat design.
- Treat source file as a one-sheet file  
Specifies that the source file is a single worksheet and you want to process the single sheet only.

*Destination* The **Destination** is any valid pathname where the output of Cleanup Schematic is placed. This entry is optional.

- Processing Options**      You may select any combination of the following options:
- Quiet mode  
Turns quiet mode on.
  - Report off-grid parts  
Causes **Cleanup Schematic** to check the entire worksheet for parts that are placed off grid and report them.
  - Repeat CLEANUP if sheet is too large to complete in one pass  
Causes **Cleanup Schematic** to repeat until the whole worksheet is completed.
  - Ignore warnings  
Causes **Cleanup Schematic** to continue running when it encounters warnings, instead of halting in the middle of execution.



## *Creating a netlist*

Traditionally, EDA tools exchanged design information using netlists and translators. Netlists and translators are limited, though, because they contain only a small part of the information in the complete design database.

With the support of the ESP design environment, OrCAD tools now relate in a new and powerful way—by exchanging design information primarily through the design database itself, rather than using netlists and translators.

To exchange information with tools created by third-party vendors with their own proprietary input formats, **Schematic Design Tools** can, as before, create netlists in a variety of industry-accepted formats.

---

### **Incremental design**

OrCAD's Release IV design database is incremental. The incremental approach speeds up the design process, especially during revision, verification, and maintenance cycles for hierarchical designs. This means less time waiting for the tools—time that can be spent designing.

The incremental netlist process is composed of three steps:

- ❖ Compile
- ❖ Link (when necessary)
- ❖ Format (when necessary)

Incremental netlisting resembles the compile and link process used to create executable computer programs from a source language (C, Pascal, or Modula-2 for instance). As in the process of creating a computer program, the schematic (source) files are processed by the compiler into an intermediate form, and are then linked together to

produce a file that contains all of the connectivity information from all of the schematic files. This process is called *building the connectivity database*.

**Compile: INET** First, the schematic files are processed by a compiler (called INET) into an intermediate form, called the *incremental connectivity database*.

The first time it runs, INET compiles all the sheets in a design. From then on, it compiles only sheets that have changed since the last time it ran. When INET runs, it compares the time stamp for a sheet against the one for the incremental connectivity database belonging to that sheet. If the sheet's time stamp is more recent than the incremental connectivity database, INET recompiles the sheet.

**Link: ILINK** Then, the increments are linked together (by the linker ILINK) to make a file that contains all the connectivity information from all of the schematic files. The result is the *linked connectivity database*.

**Format: IFORM or HFORM** Finally, the connectivity database is translated and formatted for use by other tools that cannot read the design database directly. There are two formatters: IFORM makes flat format netlists, and HFORM makes hierarchical format netlists (EDIF 2.00 and Spice). A programming language that you use to design your own netlist formats is included, along with source code for the formats already supported.

Figure 9-1 on the next page shows the process flow for creating a netlist. All netlists originate with the compile process, INET. After compilation, the incremental connectivity database can be linked or formatted or both to produce flat or hierarchical netlists for use by other tools. OrCAD's **Digital Simulation Tools** uses the incremental connectivity database directly for input. OrCAD's **PC Board Layout Tools** uses the linked version of the connectivity database, but does not use the formatting process.

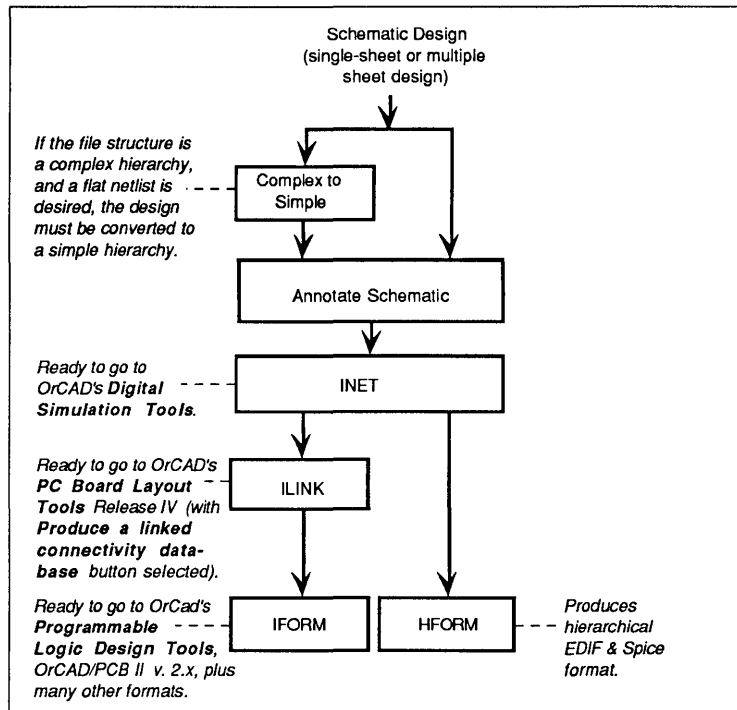

Figure 9-1. The process flow for creating a netlist.

△ **NOTE:** Figure 9-1 shows the process flow for creating a netlist. If the file structure is a complex hierarchy, it must be converted into a simple hierarchy using **Complex to Simple** before it can be flattened and annotated with unique references. **Complex to Simple** is a function provided on the **Design Management Tools** screen. This tool creates a new design with all sheets referenced only once. In this new design, a flattened netlist is then created. The OrCAD Design Environment User's Guide explains this process.



## The compiler: INET

The first step in creating either flat (one-sheet, or many sheets) or hierarchical (complex or simple) netlists is to create the incremental connectivity database.

### The incremental connectivity database

INET creates the incremental connectivity database. It consists of an .INF file for each sheet in the design and one .INX file for the entire design, as shown in figure 9-2.

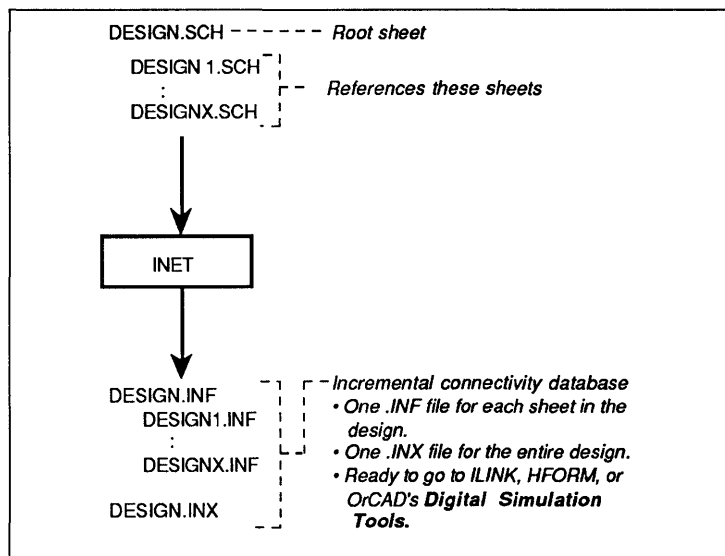

Figure 9-2. INET produces the incremental connectivity database.

### The .INF file

Compiling the root sheet of the design creates a compact database of the connectivity information for each sheet referenced by the design, which is stored in an .INF file for each sheet. This representation includes all the devices on the sheet, the connectivity between parts, the pipe commands on the sheet, and information entered in the title block.

You don't need to keep track of which sheets you've changed and therefore have to be re-compiled. INET does this for you. When INET runs, it compares the time stamp (that is, the date and time) for each sheet against the

time stamp of any pre-existing .INF file for that sheet. If the sheet is more recent than its .INF file, then INET recompiles that sheet.

- ▲ **CAUTION:** *The proper functioning of INET depends on the clock in your computer being set properly. If your clock must be reinitialized each time your computer is started, please take the time to set it properly.*

### *The .INX file*

While processing the file structure, INET constructs an .INX file from the sheet name you give it. Each sheet in the file structure is listed in the .INX file, and any sheets that were recompiled are marked with an asterisk. The .INX file is important to INET, ILINK, and IFORM. Its purpose is to speed processing and organize the database. You can use **Edit File** to view the .INX file and see the files in the design, *but do not modify the .INX file in any way.*

### **The |LINK command**

How does INET know what files belong in a file structure?

For a hierarchical file structure, the answer is simple. When a sheet is added to the hierarchy via the **PLACE Sheet** command, a name is created and stored with the sheet. Thus, the process of compiling a hierarchy becomes an iterative process of compiling a sheet, then compiling all of the sheets referenced on the sheet just compiled.

Designs that are flat, however, do not have sheet symbols to refer to the other sheets in the design. Rather, a different mechanism is used: the **|LINK** command. On the root sheet of the design, a series of text lines must be placed in the following format:

```
|LINK  
| SHEET2  
| SHEET3
```

This tells INET that the root sheet, *SHEET2*, and *SHEET3* are all part of the design. If new sheets are added to the design, simply add new text entries to the root sheet in the same vertical column as the other I LINK text. The order of the sheet names from top to bottom is the order in which all of the processors, reporters, and transfers process the design.

### The linker: I LINK

I LINK performs one of two processes:

- ❖ It creates the intermediate netlist structure. This consists of the .INS, .RES, and .PIP files. These files are used by the flat formatter, I FORM.
- ❖ It creates the linked connectivity database. This file has an extension of .LNF and is used by PC Board Layout Tools.

Figure 9-3 shows these processes.

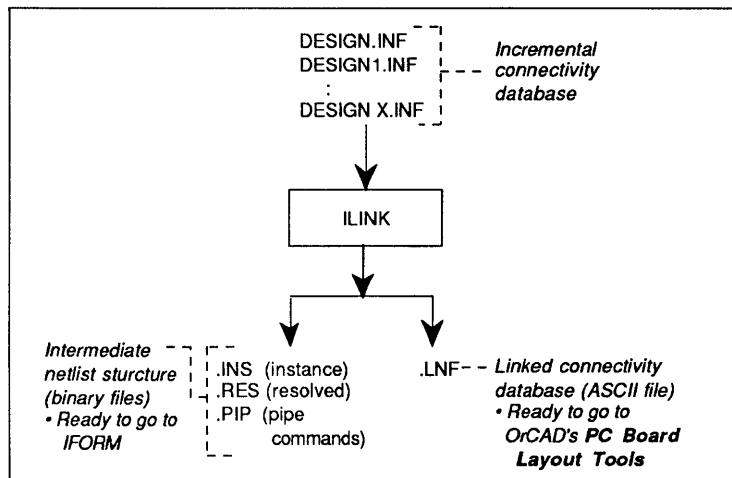

Figure 9-3. I LINK produces the intermediate netlist structure or the linked connectivity database.

△ **NOTE:** I LINK is not used for hierarchical netlist formats. See The hierarchical formatter: H FORM in this chapter.

It isn't always necessary to use ILINK. If tool sets are designed to access the incremental connectivity database directly, formatting is not needed. Some tool sets (such as **Digital Simulation Tools**) are designed to access the database in its unlinked form. Other tool sets (such as **PC Board Layout Tools**) require a linked connectivity database for all of the design. In such instances, use ILINK to create a .LNF file.

**Intermediate netlist structure**

The intermediate netlist structure consists of three binary files: the .INS, .RES, and .PIP files. These are the files used by the flat formatter, IFORM.

*The .INS file*

One of the files produced by ILINK is the instance (.INS) file. This file contains information on all the parts in all the .INF files.

*The .RES file*

Another file produced by ILINK is the resolved (.RES) file. This file contains information about the connectivity of the parts in the .INF file.

*The .PIP file*

The .PIP file is only produced when pipe commands are present on a root sheet. Several netlist formats allow pipe commands to be present on the schematic and written to the netlist. One such command is the |SPICE command used by the SPICE netlist formats.

**The linked connectivity database**

OrCAD's **PC Board Layout Tools** uses the linked connectivity database (.LNF) directly.

*The .LNF File*

The .LNF file is a giant version of all the .INF files. It has a .LNF extension because a .INF already exists for the root sheet. Producing the .LNF file from ILINK is discussed in *Chapter 10: Create Netlist*.

### The flat formatter: IFORM

If you are transferring design information to a third-party EDA tool, you will probably need to format ILINK's output to make it readable by your destination tool.

The last step formats the .INS, .RES, and .PIP files into any of over thirty different netlist formats. These formats are discussed in *Appendix B: Netlist Formats. Chapter 10: Create Netlist* explains how to create a netlist in one of these formats. Figure 9-4 shows the IFORM process.

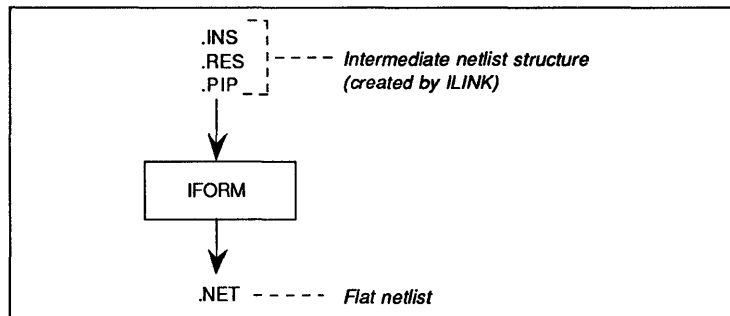

Figure 9-4. IFORM produces a flattened netlist.

### The hierarchical formatter: HFORM

Creating a hierarchical netlist is similar to creating a flat netlist except that ILINK is not used. HFORM reads the .INF files directly. These formats are discussed in *Appendix B: Netlist Formats. Chapter 11: Create Hierarchical Netlist* explains how to create a netlist in one of these formats. Figure 9-5 shows the HFORM process.

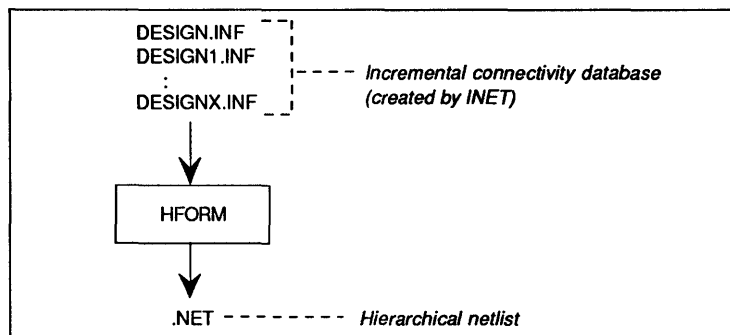

Figure 9-5. HFORM produces a hierarchical netlist.

---

## Caveats

As previously mentioned, INET is incremental. It compiles one sheet at a time. This can lead to what appear to be anomalies, but aren't.

For instance, say you have a multi-sheet file structure, and INET reports that two sheets have errors. If you fix the errors in one of those sheets, then rebuild the netlist, no errors show up. There should still be errors in the other sheet. Why didn't INET report them? Since the second sheet was not altered, it was not recompiled. If you check the .INX file, you will see that the sheet you fixed was recompiled (it has an asterisk next to it), but the other sheet was not. For this reason, when you are making a final netlist, if you are uncertain whether you have corrected all of the errors in the design, set configuration to *force* INET to compile *all* files. *Chapter 10: Create Netlist* and *Chapter 11: Create Hierarchical Netlist* and the chapters about transfers discuss this fully.





## Create Netlist

There are two basic types of netlist formats:

- ❖ A linked format where all ports and signals have been resolved across the entire design (the design is totally flat at this point). **Create Netlist**, discussed in this chapter, creates this type of netlist.
- ❖ A hierarchical format where all sheets and subsheets remain intact and are used to reference subnets. **Create Hierarchical Netlist**, discussed in *Chapter 11: Create Hierarchical Netlist*, creates this type of netlist.

These netlists are intended primarily for use in interfacing to tools outside the ESP design environment. If you are using OrCAD's **Digital Simulation Tools** or **PC Board Layout Tools**, the connectivity database is managed using the transfer buttons to those tools. A netlist is not produced when transferring to **PC Board Layout Tools** or **Digital Simulation Tools**.

---

### Linked format

The linked form reproduces the sheets giving all parts unique references and, hence, all nodes unique names. This view is the "actual" view of the design since each part is unique. However, a linked view of a design removes any evidence of the structure of the design as well as any evidence of design reuse. The design may be either a simple hierarchy or a flat file structure.



---

## Creating linked and flattened netlists

Create Netlist consists of three processes to create linked and flattened netlists. They are:

1. Process the design with the incremental compiler, INET, to produce the incremental connectivity database for the design. INET updates the incremental connectivity database efficiently by updating the database only for those sheets that have changed.
2. Next, link the incremental connectivity database into a single database that can be used by the formatting process. This is done by the netlist linker, ILINK. ILINK produces either intermediate netlist structure files that require formatting or the linked connectivity database that is ready to go to OrCAD's PC Board Layout Tools.
3. Finally, produce the final flattened netlist in one of over thirty netlist formats (Wirelist, PCAD, etc.). The netlist formatter is IFORM.

For example, if the design is called *root* and the format is contained in *my\_format*, the following processes run:

1. INET *root.sch*
2. ILINK *root.inf*
3. IFORM *root my\_format*

The formatter is actually an interpreter that uses a format specification file (*my\_format* in item 3 above) to produce the final netlist. You can write your own netlist format specification file, if you like: see *Appendix D*.

---

## Execution

Create Netlist reads a design or single sheet and creates a flat netlist.

- △ **NOTE:** If the source design is a complex hierarchy, it must first be changed into a simple hierarchy, using **Complex to Simple** on the **Design Management Tools** screen. To create a hierarchical netlist of a complex hierarchy, see Chapter 11: Create Hierarchical Netlist.

## Running Create Netlist

With the **Schematic Design Tools** screen displayed, select **Create Netlist**. Select **Execute** from the menu that displays.

When the netlisting process is complete, the **Schematic Design Tools** screen displays again.

---

## Local Configuration of Create Netlist

Since **INET**, **ILINK**, and **IFORM** are each configured individually, **Create Netlist** has three configuration screens. To configure **Create Netlist**, select **Create Netlist**. Select **Local Configuration** from the menu that displays.

The menu shown at right displays. Use this menu to choose the **Create Netlist** process to configure. You can also use it turn processes on or off. When you run **Create Netlist**, only the processes that are turned on run. For most cases, you must have **INET**, **ILINK**, and **IFORM** all turned on.

|                 |
|-----------------|
| Configure INET  |
| Configure ILINK |
| Configure IFORM |
| INET on         |
| ILINK on        |
| IFORM on        |

To turn a process on or off, choose the desired process from the menu. For example, to turn **IFORM** off, select **IFORM on** from the menu. ESP prompts:

|  |
|--|
| Select the new status of the executable item |
|--|

A menu with the options **on** and **off** displays. Select **off** to turn the process off.

△ **NOTE:** *If you are creating a netlist for either **Digital Simulation Tools** or **PC Board Layout Tools**, use the transfer buttons **To Digital Simulation** and **To Layout**, because they are already properly set up to perform the appropriate netlist processes when you transfer to the respective tool.*

*To duplicate the process of creating an incremental connectivity database to use with **Digital Simulation Tools**, turn both **ILINK** and **IFORM** off.*

*To duplicate the process of creating a linked connectivity database for **PC Board Layout Tools**, turn **IFORM** off.*

## Local Configuration of INET

With the Schematic Design Tools screen displayed, select **Create Netlist**. Select **Local Configuration** from the menu that displays, and then select **Configure INET**. A configuration screen displays (figure 10-1).

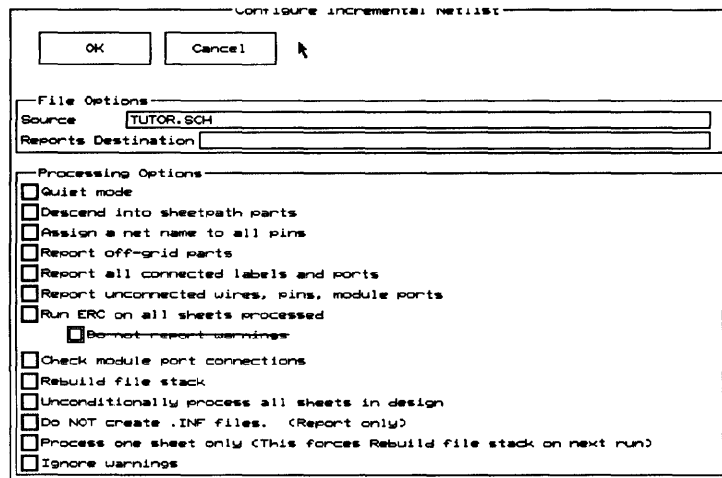

Figure 10-1. INET's local configuration screen.

### File Options

**File Options** defines the source file from which the incremental database files are created. It also defines the name of a file to contain data created by INET.

#### *Source*

The **Source** is the root of the design or the filename of a single sheet. It may have any valid pathname. One .INF file is created for each sheet referenced by the root sheet.

#### *Reports Destination*

The **Reports Destination** is the name of a file where the report is to be placed. This specification is optional. If a **Reports Destination** is not specified, the report is sent to the screen and the file #ESP\_OUT.TXT.

**Processing Options** You may select any combination of the following options:

- Quiet mode  
Turns quiet mode on.
- Descend into sheet path parts  
Tells INET to descend into parts defined as sheetpath parts. That is, it treats a sheetpath part as a sheet. This option, while designed for complex hierarchies, may be used in simple hierarchies. It is not recommended for use except for FPGA, ASIC, or other designs that require a complex hierarchy.
- Assign a net name to all pins  
Tells INET to assign a net name to all pins, including unconnected ones.
- Report off-grid parts  
Tells INET to check the worksheet for parts, sheets, labels, module ports, and power objects that are off-grid.
- Report all connected labels and parts  
Tells INET to report all connected labels and module ports.
- Report all unconnected wires, pins, module ports  
Tells INET to report all unconnected wires, pins, and module ports.
- Run ERC on all sheets processed  
Runs an electrical rules check on all sheets that INET processes. This is the same process provided by the **Check Electrical Rules** tool.

- Do not report warnings

This option is available if you select the **Run ERC on all sheets processed** option. It tells INET to not test some of the conditions for which it normally issues warnings. The conditions are:

- ❖ Two power objects connected
- ❖ Single node nets
- ❖ Input signals without a driving source

These conditions are always checked—unless you select the **Do not report warnings** option—and cannot be changed with the **Check Electrical Rules Matrix**.

Use this option with caution. You may end up with a netlist containing conditions that are not acceptable.

- Check all module port connections

Tells INET to check all module ports for correctness after tests and processing are completed.

- Rebuild file stack

Tells INET to rebuild the file stack that is used to determine the sheets that are in the incremental connectivity database. This file stack speeds the processing of the database when incremental updates occur. It may be viewed, but should not be modified. The file stack is given a .INX extension.

- Unconditionally process all sheets in design

Tells INET to ignore the incremental aspect of normal connectivity database processing. All sheets in the design are recompiled, even if the current database is up to date.

- Do NOT create .INF files (report only)

When processing the design, you may wish to leave the incremental connectivity database unchanged and only review the reports. This option causes all checks to be run and reports to be created, but does not update the incremental connectivity database.

- Process one sheet only (This forces Rebuild file stack on the next run)

Tells INET to produce an incremental connectivity database for a single sheet in a design. This option is useful for troubleshooting netlist problems. The next time INET runs, it will also rebuild the file stack used to determine the sheets that are in an incremental connectivity database.

- Ignore warnings

Causes INET to continue running when it encounters warnings, instead of halting in the middle of execution.

## Local Configuration of ILINK

With the **Schematic Design Tools** screen displayed, select **Create Netlist**. Select **Local Configuration** from the menu that displays. Select **Configure ILINK**. A configuration screen displays (figure 10-2).

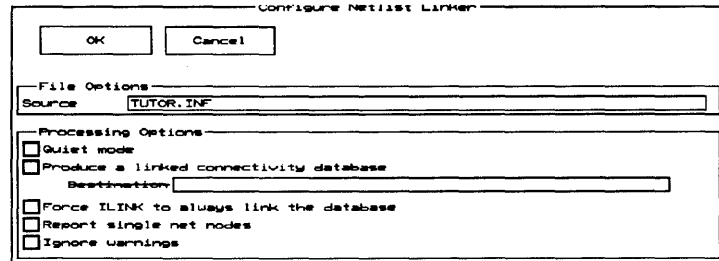

Figure 10-2. ILINK's local configuration screen.

**File Options**      **File Options** defines the source file.

*Source*      The **Source** is the incremental connectivity database root file. There *must* be an extension on the filename. The source file is the output from the INET process discussed previously and should have the recommended extension of .INF. It may have any valid pathname.



**Processing Options**

Select any combination of the following:

- Quiet mode

Turns quiet mode on.

- Produce a linked connectivity database

Tells ILINK to produce a linked connectivity database (.LNF). This text file is read by **PC Board Layout Tools**. If a destination file is not supplied, the output is placed in a file with the same name as the source, except with a .LNF extension.

A **Destination** may be supplied to override the default output file. This file may have any valid pathname.

If this option is not selected, ILINK produces the intermediate netlist structure files (.INS, .RES, and .PIP). These binary files are used by IFORM.

- Force ILINK to always link the database

Tells ILINK to force a link of the database to occur, even if the database is up to date.

- Report single net nodes

Reports all nodes that have only a single pin. This report is used to identify nodes that still need to be connected in the design.

- Ignore warnings

Causes ILINK to continue running when it encounters warnings, instead of halting.

## Local Configuration of IFORM

With the Schematic Design Tools screen displayed, select **Create Netlist**. Select **Local Configuration** from the menu that displays. Select **Configure IFORM**. A configuration screen displays (figure 10-3).

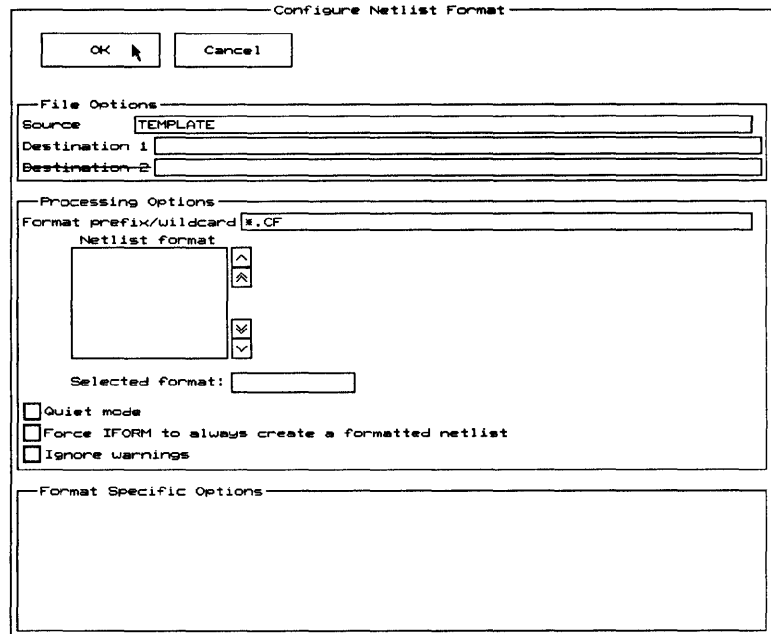

Figure 10-3. IFORM's local configuration screen.

**File Options** File Options defines the source and destination files.

*Source* The **Source** is the intermediate netlist structure from the ILINK process discussed previously and should *not* have any extensions. It may have any valid DOS pathname.

*Destination 1 & Destination 2* These are the destination files for the formatted netlist files created by IFORM. All of the netlist formats use the first destination file for the netlist. A few of the netlist formats also create a component or part file. This file, if created, is placed in the second destination. If a filename is not provided where one is needed, its data is sent to the screen.

## Processing Options

The **Format prefix/wildcard** entry box is the path from which formatting files are displayed in the **Netlist format** list box. Additionally, it provides a filter to selectively display files from the given directory. The filter defaults to \*.CF, which displays only valid flat formatter files.

The desired netlist format file is selected by clicking its name in the list box or by typing its name in the **Selected Format** entry box. If the formatter name is typed into the **Selected Format** entry box, the path in the **Format prefix/wildcard** entry box must be valid.

Select any of the following:

- Quiet mode  
Turns quiet mode on.
- Force IFORM to always create a formatted netlist  
Tells IFORM to force a format to be performed, even if the database shows the current format is up to date.
- Ignore warnings  
Causes IFORM to continue running when it encounters warnings, instead of halting.

## Format Specific Options

**Schematic Design Tools** provides formatters to create netlists in over thirty formats. When a format is selected from the **Netlist Format** list box, its formatting options are displayed in this area. *Appendix B: Netlist formats* explains each of the formats and any available options.

You may write your own netlist formats and have them appear in the **Netlist Format** list box along with the ones supplied by OrCAD. *Appendix C: Creating a custom netlist* explains this process.



## *Create Hierarchical Netlist*

There are two basic types of netlist formats:

- ❖ A hierarchical format where all sheets and subsheets remain intact and are used to reference subnets. **Create Hierarchical Netlist** creates this type of netlist and is discussed in this chapter.
- ❖ A linked format where all ports and signals have been resolved across the entire design (the design is totally flat at this point). **Create Netlist** creates this type of netlist and is described in *Chapter 10: Create Netlist*.

---

### **Hierarchical format**

The hierarchy presents the design as it was first partitioned, replete with all subsheets (children) and non-unique references and nodes. This form is generally the way “top down” designs are done and maintained. However, the design does not contain unique references nor node (signal) names (unless the “path” to the part or node is used). Hierarchies represent the “designers” viewpoint rather than the “stuff the board” view. **Create Hierarchical Netlist** is used to produce hierarchically formatted netlists.

**Create Hierarchical Netlist** consists of two processes:

1. Process the design with the incremental compiler, INET, to produce the incremental connectivity database for the design. INET updates the incremental connectivity database efficiently by updating the database only for those sheets that have changed.
2. Produce the final hierarchical netlist in the desired format (EDIF or SPICE). The netlist formatter is HFORM.

For example, if the design is called *root* and the format is contained in *my\_format* the following processes are run:

1. INET *root.sch*
2. HFORM *root my\_format*

Since there are various final formats for netlists, a method for rapidly producing different formats is required. Further, it would be nice if you could produce the desired format without too much effort. As a result, the formatter is actually an interpreter that uses a format specification file (*my\_format* in item 3 above) to produce the final netlist.

---

## Execution

**Create Hierarchical Netlist** reads a hierarchical file structure and creates a hierarchical netlist. First, it scans the file structure and creates an incremental connectivity database for the design. Then it formats the incremental connectivity database into a hierarchical (simple or complex) netlist. See *Chapter 9: Creating a netlist* for more information on the netlisting process.

### Running Create Hierarchical Netlist

With the Schematic Design Tools screen displayed, select **Create Hierarchical Netlist**. Select **Execute** from the menu that displays.

When the netlisting process is complete, the **Schematic Design Tools** screen displays again.

## Local Configuration of Create Hierarchical Netlist

Since INET and HFORM must each be configured individually, **Create Hierarchical Netlist** has two configuration screens. To configure **Create Hierarchical Netlist**, select **Create Hierarchical Netlist**. Select **Local Configuration** from the menu that displays.

The menu shown at right displays. Use this menu to choose which **Create Hierarchical Netlist** process to configure. You can also use it to turn each process on or off.

| Select Configuration |    |
|----------------------|----|
| Configure INET       |    |
| Configure HFORM      |    |
| INET                 | on |
| HFORM                | on |

When you run **Create Hierarchical**

**Netlist**, only the processes that are turned on run. For most cases, you must have both INET and HFORM turned on.

To turn a process on or off, choose the desired process from the menu. For example, to turn HFORM off, select **HFORM on** from the menu. **Schematic Design Tools** prompts:

|  |
|--|
| Select the new status of the executable item |
|--|

A menu with the options **on** and **off** displays. Select **off** to turn the process off.

△ *NOTE: If you are creating an incremental connectivity database to use with **Digital Simulation Tools**, turn **HFORM off**. To **Digital Simulation** is set up in this manner so that when you transfer to **Digital Simulation Tools**, the appropriate netlist processes are performed.*

## Local Configuration of INET

With the Schematic Design Tools screen displayed, select **Create Hierarchical Netlist**. Select **Local Configuration** from the menu that displays and then select **Configure INET**. A configuration screen displays (figure 11-1). The configuration of INET within **Create Hierarchical Netlist** is the same as within **Create Netlist**. It is repeated here for your convenience.

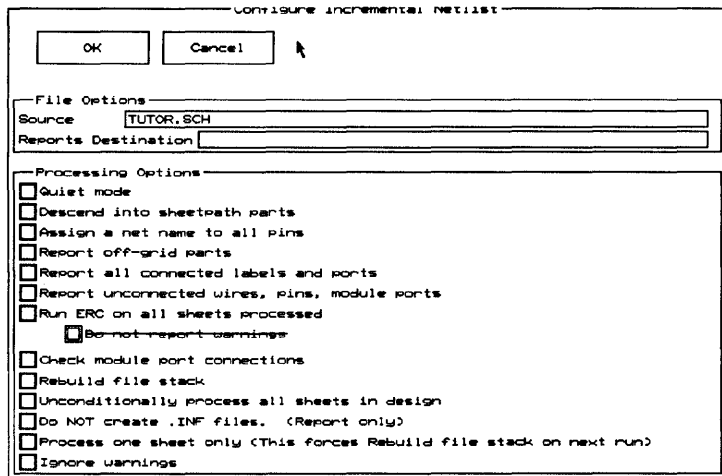

Figure 11-1. INET's local configuration screen.

### File Options

**File Options** defines the source file from which the incremental connectivity database files are created. It also defines the name of a file to contain the data INET creates.

#### Source

The **Source** is the root of the design or the filename of a single sheet. It may have any valid pathname. One .INF file is created for each sheet referenced by the root.

#### Reports Destination

The **Reports Destination** is the name of a file where the report is to be placed. This specification is optional. If a **Reports Destination** is not specified, the report is sent to the screen and the file #ESP\_OUT.TXT.

## Processing Options

You may select any combination of the following options:

- Quiet mode  
Turns quiet mode on.
- Descend into sheet path parts  
Tells INET to descend into parts defined as sheetpath parts. That is, it treats a sheetpath part as a sheet. This option, while designed for complex hierarchies, may be used in simple hierarchies. It is not recommended to be used except for FPGA, ASIC, or other designs that require a complex hierarchy.
- Assign a net name to all pins  
Tells INET to assign a net name to all pins, including unconnected ones.
- Report off-grid parts  
Tells INET to check the worksheet for parts, sheets, labels, module ports, and power objects that are off-grid.
- Report all connected labels and parts  
Tells INET to report all connected labels and module ports.
- Report unconnected wires, pins, module ports  
Tells INET to report all unconnected wires, pins, and module ports.
- Run ERC on all sheets processed  
Runs an electrical rules check on all sheets that INET processes. This is the same process provided by the Check Electrical Rules tool.



- Do not report warnings

This option is available if you select the **Run ERC on all sheets processed** option. It tells INET to not test some of the conditions for which it normally issues warnings. The conditions are:

- ❖ Two power objects connected
- ❖ Single node nets
- ❖ Input signals without a driving source

These conditions are always checked—unless you select the **Do not report warnings** option—and cannot be changed with the **Check Electrical Rules Matrix**.

Use this option with caution. You may end up with a netlist containing conditions that are not acceptable.

- Check module port connections

Tells INET to check all module ports for correctness after tests and processing are completed.

- Rebuild file stack

Tells INET to rebuild the file stack that is used to determine the sheets that are in the incremental connectivity database. This file stack speeds the processing of the database when incremental updates occur. It may be viewed, but should not be modified. The file stack is given a .INX extension.

- Unconditionally process all sheets in design

Tells INET to ignore the incremental aspect of normal connectivity database processing. All sheets in the design are recompiled, even if the current database is up-to-date.

- Do NOT create .INF files (report only)

When processing the design, you may wish to leave the incremental connectivity database unchanged and only review the reports. This option causes all checks to be run and reports to be created, but does not update the incremental connectivity database.

- Process one sheet only (This forces Rebuild file stack on the next run)

Tells INET to produce an incremental connectivity database for a single sheet in a design. This option is useful for troubleshooting netlist problems. The next time INET runs, it will also rebuild the file stack used to determine the sheets that are in an incremental connectivity database.

- Ignore warnings

Causes INET to continue running when it encounters warnings, instead of halting in the middle of execution.

## Local Configuration of HFORM

With the Schematic Design Tools screen displayed, select **Create Hierarchical Netlist**. Select **Local Configuration** from the menu that displays. Select **Configure HFORM**. A configuration screen displays (figure 11-2).

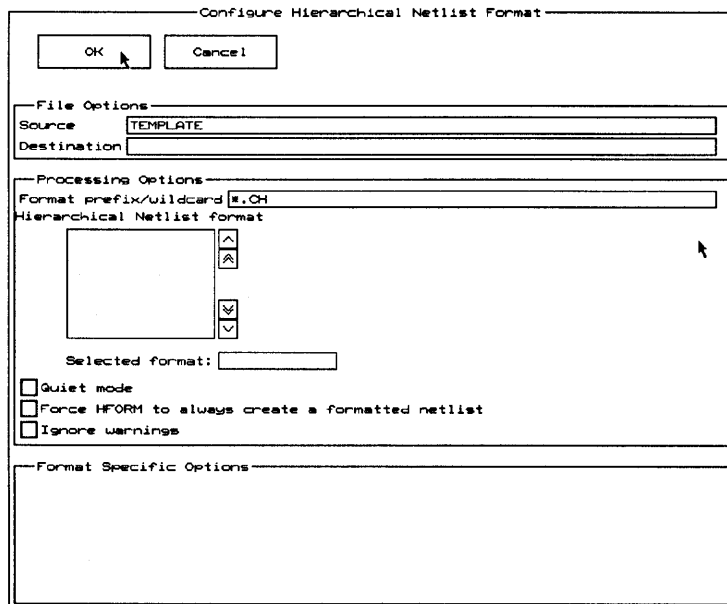

Figure 11-2. HFORM's local configuration screen.

### File Options

**File Options** defines the source and destination files.

#### *Source*

The **Source** is the root file of the design, without an extension. It may have any valid pathname.

#### *Destination 1*

**Destination 1** is the destination file for the formatted netlist file created by HFORM. If a filename is not provided, its netlist is sent to the screen.

#### *Destination 2*

Some netlist formats produce two destination files. **Destination 2** specifies the second destination file. If a filename is not provided and the format produces a second destination file, the file is sent to the screen.

**Processing Options**

The **Format prefix/wildcard** entry box is the path from which formatting files are displayed in the **Hierarchical Netlist Format** list box. It also provides a filter to selectively display files from the given directory. The filter defaults to \*.CH, which displays only valid hierarchical formatter files. The desired netlist format file is selected by clicking its name in the list box or by typing its name in the **Selected Format** entry box. If the formatter name is typed into the **Selected Format** entry box, the path in the **Format prefix/wildcard** entry box must still be valid.

You may select any combination of the following options:

- Quiet mode  
Turns quiet mode on.
- Force HFORM to always create a formatted netlist  
Tells HFORM to create a formatted netlist, even if the database indicates the current format is up-to-date.
- Ignore warnings  
Tells HFORM to exit normally rather than with a warning, if warnings are issued, but there are no errors.

**Format Specific Options**

Schematic Design Tools provides formatters to create netlists in different formats. When a format is selected from the **Netlist Format** list box, its formatting options are displayed in this area. *Appendix B: Netlist formats* explains each of the formats and any available options.

You may write your own hierarchical netlist formats and have them appear in the **Hierarchical Netlist Format** list box, along with the ones supplied by OrCAD. Additionally, you can provide up to six check box options for your netlist format. *Appendix D: Creating custom netlist formats* explains this process.





# Select Field View

## Execution

Select Field View scan a design or a single sheet and changes the visible attribute of the specified field.

### Running Select Field View

Select **Select Field View** from the **Schematic Design Tools** screen. Select **Execute** from the menu that displays.

When the specified field attributes are changed, the **Schematic Design Tools** screen displays.

## Local Configuration

With the **Schematic Design Tools** screen displayed, select **Select Field View**. Select **Local Configuration** from the menu that displays.

Select **Configure FLDATTRB**. A configuration screen displays (figure 12-1).

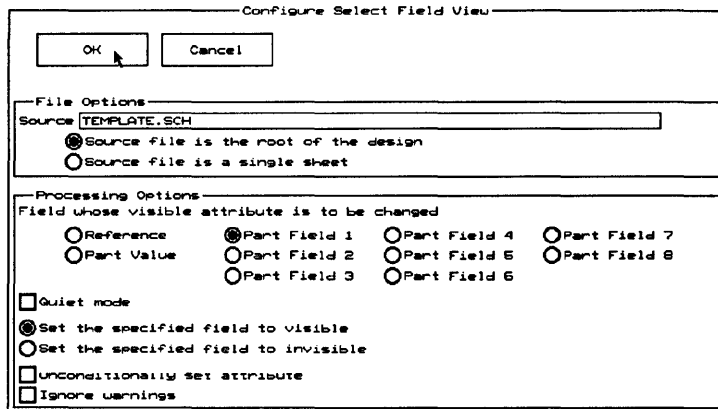

Figure 12-1. Select Field View's local configuration screen.

**File Options**     **File Options** defines the source file and its type.

*Source*     The **Source** is the file on which **Select Field View** operates. It may have any valid pathname.

After entering the source, select one of the following options:

- Source file is the root of the design  
Specifies that the source file is the root sheet name of a hierarchical or flat design. If the root sheet contains sheet symbols, then the design is hierarchical. If it contains a |Link, it is a flat design.
- Source file is a single sheet  
Specifies that the source file is a single worksheet and you want to process the single sheet only.

**Processing Options**     Select one of the following options to define which visible attribute is to be changed:

- |                                    |                                    |
|------------------------------------|------------------------------------|
| <input type="radio"/> Reference    | <input type="radio"/> Part Field 4 |
| <input type="radio"/> Part Value   | <input type="radio"/> Part Field 5 |
| <input type="radio"/> Part Field 1 | <input type="radio"/> Part Field 6 |
| <input type="radio"/> Part Field 2 | <input type="radio"/> Part Field 7 |
| <input type="radio"/> Part Field 3 | <input type="radio"/> Part Field 8 |

If desired, select the following:

- Quiet mode  
Turns quiet mode on.

Select an option to set the field's visibility attribute:

- Set specified field to visible
- Set specified field to invisible

Select either or both of the following:

- Unconditionally set attribute

All parts attributes are affected when this option is selected, regardless of the current contents of the field. When this option is not selected, only those parts with information in the field are affected.

- Ignore warnings

Causes **Set Field View** to continue running when it encounters warnings, instead of halting.







## *Update Field Contents*

---

### Execution

Update Field Contents loads information you define into the fields of parts on a specified schematic.

Update Field Contents constructs a string from the key field designators for a specified field. Then, if that string equals a match string in a designated update file, it replaces the specified field with the update value.

#### Running Update Field Contents

With the **Schematic Design Tools** screen displayed, select **Update Field Contents**. Select **Execute** from the menu that displays.

When the specified field contents are changed, the **Schematic Design Tools** screen displays again.

#### Update file format

Update Field Contents requires an update file. You create this text file using a text editor.

The update file is composed of a list of strings. Strings are delimited with single quotes. The strings are separated with any number of space, tab, or return characters. A string may not contain a single quote.

The first string serves as the match string. The second string is its corresponding update field. The third string is another match string; the fourth, its corresponding update field, and so on.

Figure 13-1 shows an example of a typical update file. To improve readability, typically a match string and its corresponding update field are placed on the same line.

In figure 13-1, match strings are in the left column and their corresponding update fields are in the right column. For example, 741s00 is a match string; its corresponding update field is 14DIP300.

|           |            |
|-----------|------------|
| '741s00'  | '14DIP300' |
| '741s138' | '16DIP300' |
| '741s163' | '16DIP300' |
| '741s373' | '20DIP300' |
| '8259a'   | '28DIP600' |

*Figure 13-1. Typical update file.*

If the update file is too large, **Update Field Contents** does not modify the schematic file. Instead, it suggests that you split your update file into smaller update files and then rerun **Update Field Contents** with each of the new update files.

## Local Configuration

With the Schematic Design Tools screen displayed, select **Update Field Contents**. Select **Local Configuration** from the menu that displays.

Select **Configure FLDSTUFF**. A configuration screen displays (figure 13-2).

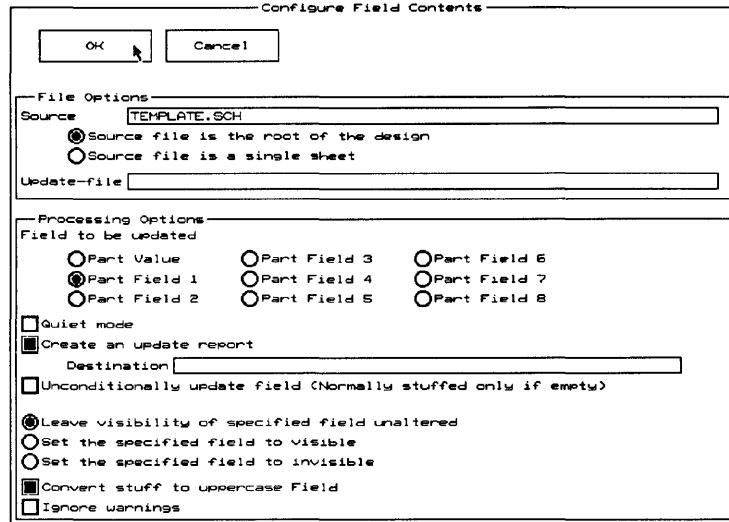

Configure Field Contents

OK Cancel

File Options

Source:

Source file is the root of the design  
 Source file is a single sheet

Update-file:

Processing Options

Field to be updated

Part Value     Part Field 3     Part Field 6  
 Part Field 1     Part Field 4     Part Field 7  
 Part Field 2     Part Field 5     Part Field 8

Quiet mode  
 Create an update report

Destination:

Unconditionally update field (Normally stuffed only if empty)

Leave visibility of specified field unaltered  
 Set the specified field to visible  
 Set the specified field to invisible  
 Convert stuff to uppercase Field  
 Ignore warnings

Figure 13-2. Local configuration screen for Update Field Contents.

**File Options** **File Options** defines the source file and its type. It also defines the update file.

*Source* The **Source** is the root of the design or the filename of a single sheet. It may have any valid pathname. After entering the source filename, select one of the following options:

- Source file is the root of the design  
Specifies that the source file is the root sheet name of a hierarchical or flat design. If the root sheet contains sheet symbols, then the design is hierarchical. If the root sheet contains a |Link pipe command, it is a flat design.
- Source file is a single sheet  
Specifies that the source file is a single worksheet and you want to process the single sheet only.

*Update-file* The **Update-file** is the name of a text file that you create. It is described at the beginning of this chapter.

**Processing Options** Select one of the following options to define which field is to be updated:

- Part Value
- Part Field 1
- Part Field 2
- Part Field 3
- Part Field 4
- Part Field 5
- Part Field 6
- Part Field 7
- Part Field 8

The field parameter selected above also identifies a key field designator. **Update Field Contents** has nine key field designators, one for the part's value, and one for each of the eight part fields. They are shown on the **Configure Schematic Design Tools** screen as shown in figure 13-3.

|                       |                      |
|-----------------------|----------------------|
| Update Field Contents |                      |
| Combine for Value     | <input type="text"/> |
| Combine for Field 1   | <input type="text"/> |
| Combine for Field 2   | <input type="text"/> |
| Combine for Field 3   | <input type="text"/> |
| Combine for Field 4   | <input type="text"/> |
| Combine for Field 5   | <input type="text"/> |
| Combine for Field 6   | <input type="text"/> |
| Combine for Field 7   | <input type="text"/> |
| Combine for Field 8   | <input type="text"/> |

Figure 13-3. Key field designators for *Update Field Contents*.

**Update Field Contents** constructs a string from the key field designator set up for the field parameter selected. For example, if you select "Part Field 3" and the **Update Field Contents Combine for Field 3** is V 2, then **Update Field Contents** constructs a string consisting of the part's value, a space, and Part Field 2.

**Update Field Contents** then tries to match that string with the match strings listed in the update file. Each match string has a corresponding update field. If a match is found, **Update Field Contents** replaces the contents of the field parameter (selected above) with the corresponding update field.

For more information about key fields, see *Chapter 1: Configure Schematic Tools*.

**Processing Options**

Select any combination of the following options:

- Quiet mode  
Turns quiet mode on.
- Create an update report  
Creates a report listing all the parts on each sheet and whether a field is updated for each part. If this option is selected, the **Destination** entry box is used to specify where the report is written.
- Unconditionally update field (Normally stuffed only if empty)  
Unconditionally changes the specified field. By default a field is only updated if it is empty. That is, fields with values already in them are not updated.

Select one of the following to indicate whether you want the updated field to be visible, invisible, or to stay in its current state:

- Leave visibility of specified field unaltered
- Set specified field to visible
- Set specified field to invisible

Select either or both of these options:

- Convert match string to uppercase
- Ignore warnings  
Causes **Update Field Contents** to continue running when it encounters warnings, instead of halting.

# PART IV : LIBRARIANS

---

Included with **Schematic Design Tools** are extensive part libraries containing more than 20,000 of the most commonly used devices in the electronics industry. These OrCAD-supplied libraries include many parts used in many types of schematic designs, so for most design work, OrCAD libraries contain all the parts you need. Sometimes, though, you may want to create your own custom parts that meet special requirements in a particular design.

Part IV describes library parts, library part files, and the librarian tools used to create and maintain your own custom parts.

- Chapter 14:* *About libraries* introduces the two forms of a library file: library source files and compiled library files. This chapter also describes two ways to edit a library part and lists the basic components of a part.
- Chapter 15:* *List Library* describes how to list a library's contents with **List Library**.
- Chapter 16:* *Archive Parts in Schematic* describes how to use **Archive Parts in Schematic** to make a library source file or a library string file containing only those parts used in a particular schematic worksheet.
- Chapter 17:* *Edit Library* describes the **Edit Library** graphical part editor and its commands.
- Chapter 18:* *Decompile Library* describes how **Decompile Library** converts a compiled library file into a library source file.
- Chapter 19:* *Creating a library source file with a text editor* describes, in detail, how to create a library source file with a text editor.
- Chapter 20:* *Symbol Description Language* explains how to define a part in a custom library using OrCAD's Symbol Description Language (SDL).
- Chapter 21:* *Compile Library* describes how **Compile Library** converts a library source file into a compiled library file.







## *About libraries*

This chapter introduces library files and library parts. It describes the two forms of a library file, two ways to create library files, and the components of a library part.

---

### Library files

Libraries are used to group and organize the more than 20,000 parts supplied with **Schematic Design Tools**.

Parts in a particular library have common characteristics, such as parts produced by one manufacturer, parts with a common application, or parts in a family. Some examples are: TTL.LIB, INTEL.LIB, ANALOG.LIB, PCBDEV.LIB, or PLDGATES.LIB.

Some libraries contain hundreds of parts; some contain just a few. **Schematic Design Tools** includes many libraries.

The libraries have been created over time. Old parts are not deleted because you may want to look at a design containing an old part. Also, some pre-release parts (from various manufacturers) are included.

Library files come in two forms: library source files and compiled library files.

**Library source file**

A *library source file* is much like the source code for a computer program. It is a text file containing instructions in the OrCAD's Symbol Description Language, which is described in *Chapter 20: Symbol Description Language*. These instructions specify how to represent a part graphically.

You can create and modify a library source file with the **Edit File** editor. You then run the tool called **Compile Library** on the library source file to produce a compiled library file.

**Decompile Library** and **Archive Parts in Schematic** tools can also produce library source files. For details on **Compile Library**, **Decompile Library**, and **Archive Parts in Schematic**, see chapters 21, 18, and 16, respectively.

**Compiled library file**

A *compiled library file* is the compiled version of a library source file. This type of file is produced by **Compile Library** or the **Edit Library** graphical part editor (described in chapter 17). This is the type of library file the schematic editor, processors, reporters and transfer tools can read. A compiled library file takes much less disk space than its corresponding library source file and is faster to load and access.

By convention, the names of compiled library files have .LIB as the file extension. For example, MOTO.LIB is the name of the OrCAD-supplied library of Motorola components. Also, by convention, library source files have a .SRC file extension. Note, however, the .LIB and .SRC extensions are conventions, not requirements.

When you configure **Schematic Design Tools**, you specify which of the compiled libraries are loaded when you run a schematic editor, processor, reporter or transfer tool. For details, see *Chapter 1: Configure Schematic Tools*.



**NOTE:** Libraries can be loaded into main system memory (RAM), EMS memory, or your disk. See Chapter 1: Configure Schematic Tools for details.

You may have parts with the same name in different libraries. If you do and these libraries are selected during configuration, when **Draft** looks for a part, it searches the libraries in the order that they are listed in the **Configured Libraries** list box on the **Configure Schematic Design Tools** screen. The first part **Draft** finds with that name is the part **Draft** gets.

### List parts in a library

You can view the names of the parts in a library using the **List Library** tool. For example, one of the OrCAD libraries is called TTL.LIB. To find out what parts are in this library, follow these steps:

1. Display **List Library**'s local configuration screen.
2. Select a library from the list shown in the **Files** list box. Click on its name or type its name in the **Source** text entry box.
3. Click **OK**.
4. Double-click on **List Library**.

**List Library** displays a list of the part names in TTL.LIB in the window at the bottom of the screen. You can also tell **List Library** to send its output to a file instead of the screen. For details on **List Library**, see Chapter 15.

---

### Creating library files

There are two ways to create your own custom libraries or modify existing libraries.

- ▲ **CAUTION:** *Avoid changing parts and saving them in libraries with the same names as OrCAD libraries. Instead, create your own custom libraries with unique names. This way you can avoid the risk of losing your parts when OrCAD updates the libraries in the future.*

**Edit Library** One way is to use **Edit Library**, a graphical part editor. With **Edit Library**, you use commands similar to **Draft's** to construct or modify a part graphically and add it to a new or existing library. The part being edited appears on **Edit Library's** screen exactly as it will appear when you place it on a schematic worksheet with **Draft**. **Edit Library** automatically converts the graphical screen symbols to the compiled format the schematic editor, processors, reporters, and transfer tools use.

You can use OrCAD libraries as the starting point for your own custom libraries. Make a copy of the OrCAD library file and then modify the parts with **Edit Library**. Chapter 17 describes **Edit Library**.

**Text editor** Another way to create a custom library is using a text editor. You create a library source file, then run **Compile Library** on it to produce a compiled library file. Library source files are described in chapter 19. **Compile Library** is described in chapter 21.

Figure 14-1 shows the development process using **Compile Library** to create a custom part library.

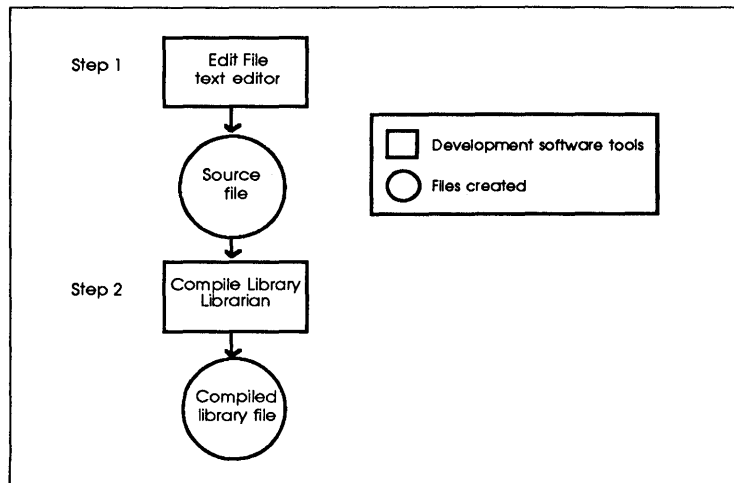

Figure 14-1. How to use **Compile Library** to develop a library.

You can also use OrCAD libraries as the starting point for your custom library. Select a library file, convert it to source form using **Decompile Library**, and then edit it using **Edit File**. When you are done editing, compile the file using **Compile Library**. Figure 14-2 shows this process.

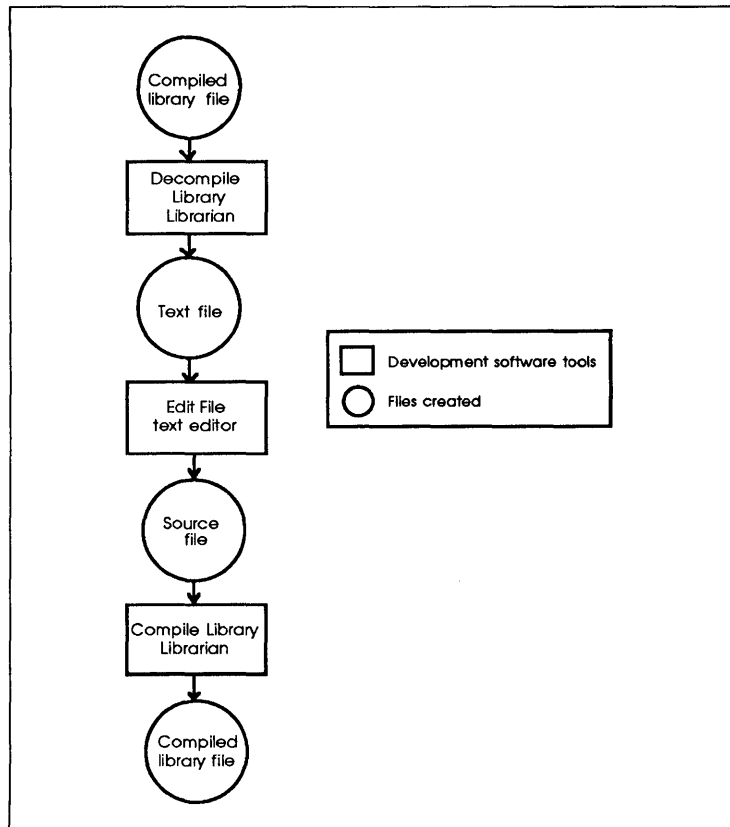

Figure 14-2. How to use *Decompile Library* and *Compile Library* together to develop a library.

## Components of a library part

Whether you use **Edit Library** or a text editor along with **Compile Library** and **Decompile Library**, you build library parts from the same basic components.

A library part is made up of the following components:

- ❖ Body
- ❖ Pins
- ❖ One or more names
- ❖ An optional sheetpath designator
- ❖ An optional reference designator
- ❖ Optional text

These components are described on the next pages.

**Body** Every part has either a block, a graphic, or an IEEE body.

**Block** A block part is one whose body is a square or rectangle. For example, a memory chip is a block part. Figure 14-3 shows examples of parts with block bodies. A block part can be up to 12.7 inches by 12.7 inches in size.

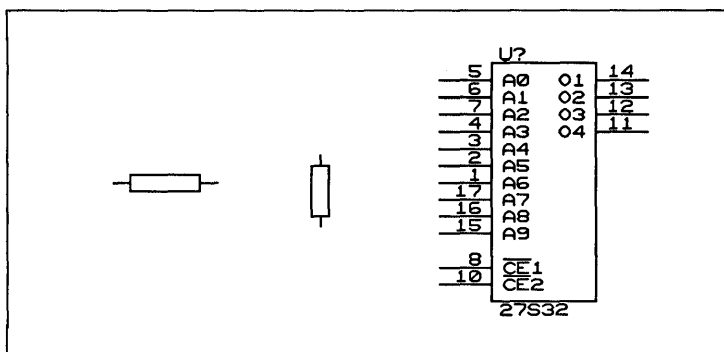

Figure 14-3. Parts with block bodies.

**Graphic** A graphic part is one whose body contains graphical information such as circles, arcs, and filled areas. It may also contain lines and text. A graphic part can be a simple square or rectangle, or it can be something more complex, such as an OR gate. A graphic part has no visible pin names.

If your part is larger than 1.2 inches by 1.2 inches, it must be an IEEE part (rather than a graphic part). However, if a graphic part's X axis is less than 1.2 inches, its Y axis can be larger than 1.2 inches, and vice versa. Think of it as a rubber band . . . if you stretch it in one direction, it thins out in the other.

Figure 14-3 shows examples of parts with graphic bodies.

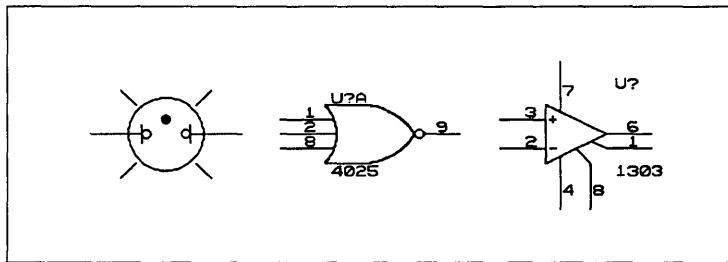

Figure 14-4. Parts with graphic bodies.

**IEEE** An IEEE part is one that complies with the ANSI/IEEE standard.<sup>1</sup> IEEE parts differ from graphic parts in that they may not contain arcs or fills, and they may be larger. You must always create an IEEE part (rather than a graphic part) if the part will be larger than 1.2 by 1.2 inches. An IEEE part can be up to 12.7 inches by 12.7 inches in size.

<sup>1</sup> See ANSI/IEEE Std 91-1984: *IEEE Standard Graphic Symbols for Logic Functions*, © 1984, or *Graphic Symbols for Electrical and Electronics Diagrams*, © 1975; both published by The Institute of Electrical and Electronics Engineers, Inc.



**Pins** Each pin has a type, a shape, a name, and possibly a number.

*Pin type* Pin types are:

- |                 |                  |
|-----------------|------------------|
| ❖ Input         | ❖ Passive        |
| ❖ Output        | ❖ 3 state        |
| ❖ Bidirectional | ❖ Open collector |
| ❖ Power         | ❖ Open emitter   |

A pin can have only one type. Pin type is not apparent from the representation of the part on the screen. Power pins are invisible.

*Pin shape* The pin shape determines how the pin appears. A pin can have either a normal or a short lead. A normal lead can also have a clock symbol and an inversion bubble (called a dot); a short lead cannot.

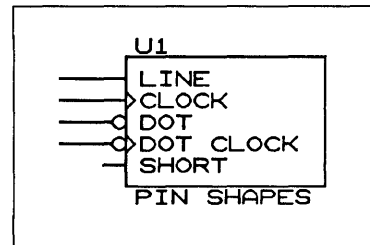

The figure above shows a part with each type of pin shape. A clock symbol is shown as a ">" on the lead. An inversion bubble, or dot, is shown as a circle on the lead.

*Pin number* If the part has pin numbers they appear outside the part beside the pins. Figures 14-3 and 14-4 show parts with pin numbers.

*Pin name* The pin name is associated with the pin function. For example, A0 represents an address line, and CLR represents the clear function. In Block parts, pin names appear inside the part beside the pins. In IEEE parts, pin names appear outside the body of the part near the pin when the part is viewed using *Edit Library*; however, the IEEE part's pin names do not display in *Draft*, nor will they print or plot. Graphic parts do not display pin names. They are, however, stored with the part.

- Names** A part has one or more names. Parts with identical symbols are represented in a library as one part with multiple names. For example, 2114, 2146, and 2149 identify the same symbol and represent a 1K x 4 static RAM.
- Sheetpath designator** A sheetpath designator is a filename referencing a schematic file that is used as a part. As such, a sheetpath part should be saved in the library directory so it can be used in any schematic.
- The sheetpath designator is optional. Sheetpath designators provide a higher level of abstraction for the circuit under construction and are useful for frequently used circuits of macro functions, such as gate arrays or FPGAs.
- Reference designator** The reference designator specifies the default reference used when the part is first placed on a worksheet with **Draft**.
- The prefix of the reference designator represents the class of the part. For example, U is normally used for ICs, Q is for transistors, C is for capacitors, and R is for resistors. The reference designator is optional and will default to "U" if one is not specified.





## List Library

---

### Execution

List Library lists the names of the parts in a library. The list can be shown on the screen or sent to a text file you view using **Edit File**.

### Running List Library

With the **Schematic Design Tools** screen displayed, select **List Library**. Select **Execute** from the menu that displays.

- ❖ If a destination is not specified on **List Library's** configuration screen, the parts are listed in the monitor box at the bottom of the screen. If the report is configured to report the total number of devices in the library, the parts are not listed (See *Local Configuration* in this chapter).
- ❖ If a destination is specified on **List Library's** configuration screen, use the **Edit File** editor to view the file created by **List Library**.

When **List Library** is complete, the **Schematic Design Tools** screen appears again.

Figure 15-1 shows a sample of one kind of list produced by **List Library**. Follow the prefix column down to the number on the left that corresponds to the library part you want. Two asterisks (\*\*) mean the part is in the library you listed. Two periods (..) mean the part is not in the library you listed.

| TTL.LIB          | 74LS | 74S | 74ALS | 74AS | 74HCT | 74HC | 74ACT | 74AC | 74AHCT | 74FCT | 74F | 74C | 74 |
|------------------|------|-----|-------|------|-------|------|-------|------|--------|-------|-----|-----|----|
| 00               | **   | **  | **    | **   | **    | **   | **    | **   | **     | ..    | **  | **  | ** |
| 01               | **   | **  | **    | ..   | ..    | **   | ..    | ..   | **     | ..    | ..  | ..  | ** |
| 02               | **   | **  | **    | **   | **    | **   | **    | **   | **     | ..    | **  | **  | ** |
| 03               | **   | **  | **    | ..   | **    | **   | ..    | ..   | **     | ..    | ..  | ..  | ** |
| 04               | **   | **  | **    | **   | **    | **   | **    | **   | **     | ..    | **  | **  | ** |
| 05               | **   | **  | **    | ..   | **    | **   | ..    | ..   | **     | ..    | ..  | ..  | ** |
| <i>and so on</i> |      |     |       |      |       |      |       |      |        |       |     |     |    |
| 75188            | ..   | ..  | ..    | ..   | ..    | ..   | ..    | ..   | ..     | ..    | ..  | ..  | .. |
| 75189            | ..   | ..  | ..    | ..   | ..    | ..   | ..    | ..   | ..     | ..    | ..  | ..  | .. |

Figure 15-1. An example of List Library output for TTL.LIB.

For example, follow the column under “74AS” down to the “04” row. The double asterisks means the part 74AS04 is in the TTL.LIB library.

## Local Configuration

With the Schematic Design Tools screen displayed, select List Library. Select Local Configuration from the menu that appears.

Select Configure List Library. A configuration screen displays (figure 15-2).

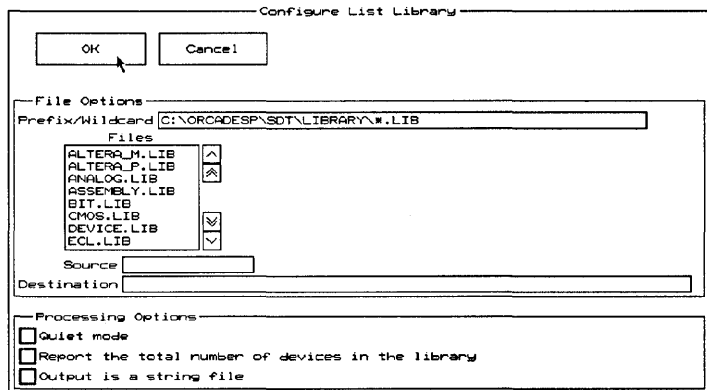

Figure 15-2. List Library’s local configuration screen.

**File Options** **File Options** tells the library to be listed and the destination of the output.

*Prefix/Wildcard* Enter a pathname and wildcard to indicate which files to display in the list box with scroll buttons. The asterisk character (\*) is used as a wildcard.

The default is:

```
\ORCADESP\SDT\LIBRARY\*.LIB
```

If you erase the entire field, the entry is restored to the prefix specified in **Configure Schematic Design Tools**.

*Files* The files that match the search filter entered in the **Prefix/Wildcard** entry box and those that match the filter in the current design directory are listed in this box. Files in the current directory are shown with .\ before their names. Use the scroll buttons at the right of the box to scroll the list of libraries up and down.

When you see the library you would like to list, select it. Its path and filename display in the **Source** entry box.

*Source* The **Source** names an existing compiled library file. Specify the source file by selecting it from the list box or by simply entering its name in the **Source** entry box.

*Destination* The **Destination** is any valid pathname and is where the list is placed. If you name an existing file, when you run **List Library**, it asks if you want to overwrite the existing file. You cannot append to an existing file.

If a **Destination** is not specified, the output displays in the monitor box at the bottom of the screen.

△ **NOTE:** A question mark (?) in an entry box tells ESP to default to the **Startup Design** name. This simplifies changing between designs: all you need do is change the **Startup Design** on the **Configure ESP** screen, exit ESP, then restart ESP by entering ORCAD.

For example, if you enter `? .LIB` in the **Source** entry box and the **Startup Design** is configured as "TUTOR," the next time you look at the local configuration, the **Source** entry box will be configured as "TUTOR.LIB." If you then change the **Startup Design** to "DESIGN2" and restart ESP, the **Source** entry box will be configured as "DESIGN2.LIB."

### Processing Options

You may select any combination of the following options:

Quiet mode

Turns quiet mode on.

Report the total number of devices in the library

Causes **List Library** to simply report how many parts are in the library, rather than create a list of parts.

Output is a string file

Causes **List Library** to list the names of the parts in the design in string file format. String files are used to create libraries with **Compile Library**.

String files can be used to create libraries with a subset of parts, or as the "left" column of a stuff file.

Below is an example of a short string file:

```
'GND'  
'74LS00'  
'RESISTOR'  
'SW SPDT'
```



## *Archive Parts in Schematic*

---

### Execution

**Archive Parts in Schematic** takes all the library parts used in a set of schematic files and makes a library source file or a library string file containing only those parts used in the schematic files.

The **Archive Parts in Schematic** tool scans a design or a single sheet.

#### Running Archive Parts in Schematic

With the **Schematic Design Tools** screen displayed, select **Archive Parts in Schematic**. Select **Execute** from the menu that displays.

The monitor box at the bottom of the screen displays messages while **Archive Parts in Schematic** creates the source file or the string file.

When **Archive Parts in Schematic** is complete, the **Schematic Design Tools** screen appears. You may look at the file created by **Archive Parts in Schematic** using a text editor.



## Local Configuration

With the Schematic Design Tools screen displayed, select **Archive Parts in Schematic**. Select **Local Configuration** from the menu that displays. The menu below displays.

**Archive Parts in Schematic** is a two-process function. The first process is called **LIBARCH**. **LIBARCH** builds a library of all the components in the design or sheet.

Select Configuration

|                    |
|--------------------|
| Configure LIBARCH  |
| Configure COMPOSER |
| LIBARCH on         |
| COMPOSER on        |

The second process, called **COMPOSER**, compiles the source file produced by **LIBARCH** into a form usable by the schematic editor, processors, reporters, and transfer tools. Each of the two processes can be configured and each can be turned on and off.

To configure **LIBARCH**, follow the instructions in the *Configure LIBARCH* section on the next page.

To configure **COMPOSER**, see the *Configure COMPOSER* section in this chapter or the *Local Configuration* section of *Chapter 21: Compile Library*.

If you want to run both tools at the same time, leave both **LIBARCH** and **COMPOSER** on. Otherwise, set **LIBARCH** to on, and **COMPOSER** to off.

## Configure LIBARCH

Select **Configure LIBARCH**. A configuration screen appears (figure 16-1).

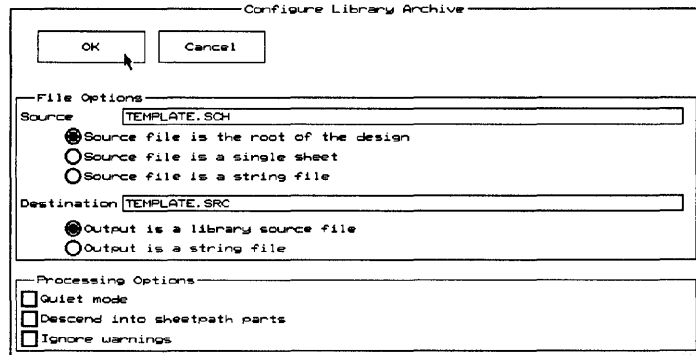

Figure 16-1. Archive Parts in Schematic's local configuration screen.

**File Options** File Options defines the source filename and its type. It also defines the destination filename and its type.

*Source* The **Source** may be the root sheet name of a hierarchical or flat design, the filename of a one-sheet file, or a string file. If a pathname is not given, **Archive Parts in Schematic** looks for the file in the current design directory.

△ **NOTE:** A question mark (?) in an entry box tells ESP to default to the *Startup Design* name. This simplifies changing between designs: All you need do is change the *Startup Design* on the *Configure ESP* screen, exit ESP, then restart ESP by entering ORCAD.

*For example, if you enter ?.SCH in the Source entry box and the Startup Design is configured as "TUTOR," the next time you look at the local configuration, the Source entry box will be configured as "TUTOR.SCH." If you then change your Startup Design to "DESIGN2" and restart ESP, the Source entry box will be configured as "DESIGN2.SCH."*

After entering the source filename, select one of the following options:

- Source file is the root of the design  
Specifies that the design consists of more than one worksheet. If the root sheet contains sheet symbols, the design is a hierarchy. If the root sheet contains |LINK followed by a list of files, the design is flat.
- Source file is a single sheet  
Specifies that the source file is a single worksheet and you want to process the single sheet only.
- Source file is a string file  
Specifies that the source file is a string file. **Archive Parts in Schematic** creates a library source file containing the parts listed in the string file.

You can create a string file from a design by running **Archive Parts in Schematic** with the **Output is a string file** option selected in the tool's local configuration.

To create a special library with the string file output of **Archive Parts in Schematic**, run the tool again on the string file created the first time you ran **Archive Parts in Schematic**. This time, make the output a library file, and the source the string file you created the first time you ran **Archive Parts in Schematic**.

*Destination*

The **Destination** is any valid path and filename and is where the library source file or string file is placed. If a filename is given without a pathname, **Archive Parts in Schematic** places the resulting library source file or string file in the current design directory. The default name for the file is *design.SRC*, where *design* is the name of the current design.

If **Destination** is not specified, the output is directed to the monitor box at the bottom of the screen. If the destination is the name of an existing file, **Archive Parts in Schematic** asks if you want to overwrite the existing file.

After entering the destination filename, select one of the following options:

- Output is a library source file  
Tells **Archive Parts in Schematic** to make a source file (a text file describing the parts using OrCAD's Symbol Description Language).
- Output is a string file  
Tells **Archive Parts in Schematic** to make a string file. A string file is a text file consisting of the names of all the parts used in a schematic file. The names are delimited with single quotes and each appears on a separate line. A string file can be used to create an include file for the **Create Bill of Materials** reporter, or to create a file to be used to create a special library.

To create a special library with the string file output of **Archive Parts in Schematic**, run the tool again on the string file created the first time you ran **Archive Parts in Schematic**. This time, make the output a library file, and the source the string file you created the first time you ran **Archive Parts in Schematic**.

**Processing Options** You may select any combination of the following options:

- Quiet mode  
Turns quiet mode on.
- Descend into sheetpath parts  
Tells **Archive Parts in Schematic** to descend into any parts defined as sheetpath parts. Without this option selected, **Archive Parts in Schematic** treats the sheetpath itself as a part to be archived and does not archive the parts within a sheetpath.
- Ignore warnings  
Causes **Archive Parts in Schematic** to continue running when it encounters warnings, instead of halting in the middle of execution.

## Configure COMPOSER

Select **Configure COMPOSER**. A configuration screen appears (figure 16-2).

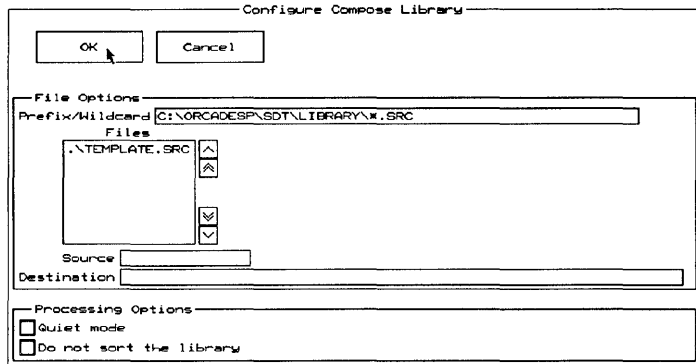

Figure 16-2. Configuration screen for *Compile Library*.

### File Options

**File Options** defines the library source file and the resulting library file.

### Prefix/Wildcard

Enter a pathname and wildcard to indicate which files to display in the list box with scroll buttons. The asterisk character (\*) is used as a wildcard.

The default is:

```
\ORCADESP\SDT\LIBRARY\*.SRC
```

If you do not specify a prefix, **Compile Library** looks for files in the current design directory.

If you erase the entire field, the entry will be restored to whatever prefix is specified in **Configure Schematic Design Tools**.

**Files** The files that match the search filter entered in the **Prefix/Wildcard** entry box and those that match the filter in the current design directory are listed in this box. Files in the current directory are shown with `.\` before their names. Use the scroll buttons to scroll the list of files up and down.

When you see the file you would like to compile, select it. Its filename displays in the **Source** entry box.

**Source** The **Source** is the text file describing your custom parts using OrCAD's Symbol Description Language. The default is the file `design.SRC`, where `design` is the name of the current design. The convention is to name source file with `.SRC` extensions, although this is not a requirement.

Specify the source file by selecting it from the list box described above, or enter its name by simply typing it in this entry box and pressing `<Enter>`.

△ **NOTE:** A question mark (?) in an entry box tells ESP to default to the **Startup Design** name. This simplifies changing between designs: all you need do is change the **Startup Design** on the **Configure ESP** screen, exit ESP, then restart ESP by entering `ORCAD`.

For example, if you enter `?.SRC` in the **Source** entry box and the **Startup Design** is configured as "TUTOR," the next time you look at the local configuration, the **Source** entry box will be configured as "TUTOR.SRC." If you then change the **Startup Design** to "DESIGN2" and restart ESP, the **Source** entry box will be configured as "DESIGN2.SRC."

**Destination** The **Destination** is the library file to be created by **Compile Library**. If you give the name of an existing file, **Compile Library** asks if you want to overwrite the existing file. You cannot append to an existing file. The default destination is `design.LIB`, where `design` is the name of the current design.

**Destination** may be a complete pathname.

**Processing Options**

Select either or both of the following options:

Quiet mode

Turns quiet mode on.

Do not sort library

Tells **Compile Library** to save parts in the source file in the order they were entered (rather than sorting them alphabetically, which is the default).



## *Edit Library*

**Edit Library** is a graphical part editor used to create and edit library parts. This chapter describes how to configure and run **Edit Library**, tells how **Edit Library** uses bitmaps and vectors, and lists some part limitations you should consider when using **Edit Library**. A detailed description of the **Edit Library** commands is given in the *Command Reference* section in this chapter.

---

### About Edit Library

Use **Edit Library** to:

- ❖ Create a new part and add it to an existing or a new library.
- ❖ Create a part similar, but not identical, to a part in an OrCAD library. You run **Edit Library**, get the similar part, write it out to a new or existing library, edit it, and then save the changes to the library.
- ❖ Modify an existing part in an existing library.

See *Chapter 5: Creating a custom component* in the *Schematic Design Tools User's Guide* for an example that shows how to use **Edit Library** to create a new part and add it to an existing library file.



▲ **CAUTION:** *Avoid changing parts and saving them in libraries with the same names as OrCAD libraries. Instead, create your own custom libraries with unique names. This way you can avoid losing your parts when OrCAD updates the libraries.*

*To modify parts in one of OrCAD's libraries, extract the parts (using GET PART), export them to a temporary data file, import the data from the temporary data file into a custom library, edit the parts' definitions, and then write them to the custom library.*

---

## Bitmaps and vectors

The body of a library part can be defined in vector form and bitmap form. **Edit Library** only reads the vector description of a part. Before you use **Edit Library**, you should become familiar with vectors and bitmaps and how **Edit Library** uses them.

A *vector* is a set of numbers that describe the starting and ending coordinates, size, and so on, of a graphic object. For example, the following vector describes a straight line:

```
LINE +1.0 +2.0 +1.0 +4.0
```

The first two numbers (+1.0, +2.0) are the X and Y coordinates of the beginning of the line. The second two numbers (+1.0, +4.0) are the X and Y coordinates of the end of the line. Circles, arcs, and text can be specified in a similar way.

Although vectors are a precise way to specify graphic objects, bitmaps are a faster way to send the objects to a screen or printer. A *bitmap* is a set of bits in memory correlating to pixels on a screen or dots on a printer. A bitmap tells which pixels to "turn on" on a screen and which dots to print on a printer. Unlike vectors, bitmaps require little processing before being displayed or printed.

△ **NOTE:** *A disadvantage of bitmaps is that a bitmap of a large object requires a lot of memory. This is true even if most of the pixels are not used.*

*IEEE parts are represented by vectors. Although the main purpose for IEEE type parts is to support drawing to the IEEE standard, IEEE type parts are also useful for handling parts that are not practical as bitmaps.*

If you use **Edit Library** to create or edit a part and then write it out to a library, the part is stored in *both* vector and bitmap form. The bitmap description is used by **Draft** and **Print Schematic** to bypass the time-consuming process of converting vectors to bitmaps. The vector description is used by **Plot Schematic** to produce high quality plots.

▲ **CAUTION:** *Although the parts in the OrCAD libraries use bitmap and vector definitions, parts in other libraries may not use vectors. Be careful when using **Edit Library** to edit a part without a vector description. If you do, you will not see the part's shape on the screen. The bitmap defining the shape is still there, but **Edit Library** is not designed to read bitmaps. If you write the part back to the library with the **LIBRARY Update Current** command followed by **QUIT Update** or **QUIT Write**, you save the part as it appears on the screen—that is, without a body. You lose the bitmap.*

*If you're not sure whether a part has a vector definition, run **Decompile Library** on the library file containing the part. Then use a text editor to look at the library source file produced by **Decompile Library**. If the part has a vector definition, it always appears at the end of the part's definition.*

## Editing a part with Edit Library

To create or edit a part in a library, follow these steps:

1. Select **Edit Library's Local Configuration** option. Select the library to edit from the **Files** list box. If you want to create a new library, enter its name in the **Source** text entry box.
2. Run **Edit Library**. **Edit Library** reads the library file into memory or creates the new one you named. This is not necessary if you are creating a new library

3. Retrieve a part with the **GET PART** command and edit it. The changes you make are stored in a temporary work area; the copy of the library in memory remains unchanged.

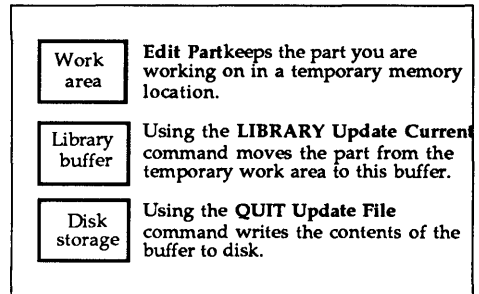

4. Select the **LIBRARY Update Current** command. The copy of the library in memory gets the new or modified part. You could instead decide to create an export file and not modify the library (See the **Export** command description in this chapter).
5. Select the **QUIT Update File** command (saves the modified library to the same file) or **QUIT Write to File** command (saves the *entire* modified library to a new file you specify).

Issuing either of these commands without previously issuing **LIBRARY Update Current** results in no modification to the library, even if you have retrieved and modified or constructed a part.

▲ **CAUTION:** *Update the library using the **LIBRARY Update Current** command before you select **QUIT Update File** or **QUIT Write to File** or the current part will be lost.*

It is often convenient to create a new part by editing an existing part. To do this, follow these steps:

1. Get the part.
2. Use the **Name Add** command to give it the new name. Use the **Name Delete** command to delete the old name. Do this before other editing to protect the old part from being overwritten.

3. Edit the part using **Edit Library's** commands.
4. Select **LIBRARY Update Current** and **QUIT Update File** as needed.

### **Limit on a part's complexity**

Using **Edit Library**, you construct a part from lines, arcs, circles, and so on. Each part has a maximum number of such elements allowed. The limit is for each part body; that is, the limit for a normal part is distinct from the limit for its converted form. Also, the limit does not depend on the number of parts per package.

For example, consider a part with four parts per package and a converted form. There are two limits pertinent for this part, one for the normal version and one for the converted form version. If you edit the part so it has only two parts per package, the limits do not change.

The limits for graphic parts are as follows:

|         |  |
|---------|--|
| Lines   | 127  |
| Circles | 127. The IEEE symbol $\circ$ (negation) counts as a circle |
| Text    | 255 strings. Each string has a maximum of 10 characters    |
| Arcs    | 63   |
| Fills   | 31   |

IEEE parts are constructed in an area of 4096 bytes. The number of bytes required for each type of object are:

|              |                           |
|--------------|---------------------------|
| Lines        | 9                         |
| Circles      | 8                         |
| IEEE Symbols | 8                         |
| Text         | 7 + length of text (8-17) |

Hence, the total number of objects within an IEEE part is dependent on the mixture of the different type of objects in the part. At most, an IEEE part can have:

|              |                       |   |         |
|--------------|-----------------------|---|---------|
| Lines        | $\frac{4096}{9}$      | = | 455     |
| Circles      | $\frac{4096}{8}$      | = | 512     |
| IEEE Symbols | $\frac{4096}{8}$      | = | 512     |
| Text         | $\frac{4096}{8...17}$ | = | 512-240 |

**Limit of total library size**

Each library consists of several parts, each of which occupies its own block in memory. Each block can occupy up to 65536 bytes. As you add parts to the library, you may fill one of these blocks. At this point, the library is full. As you approach the memory limit, **Edit Library** displays a warning message so you do not lose any work. For information about checking the amount of remaining memory in these blocks, see the **CONDITIONS** command later in this chapter.

---

**Execution**

With the **Schematic Design Tools** screen displayed, select **Edit Library**. Select **Execute** from the menu that displays.

**Edit Library's** work area displays. Press <Enter> to display **Edit Library's** main menu. These commands and the menus and commands accessed by the main menu commands are described in the *Command reference* section in this chapter.

When you are finished editing library parts and leave the **Edit Library** tool, the **Schematic Design Tools** screen appears.

## Local Configuration

With the Schematic Design Tools screen displayed, select **Edit Library**. Select **Local Configuration** from the menu that displays.

Select **Configure LIBEDIT**. Edit Library's configuration screen appears (figure 17-1).

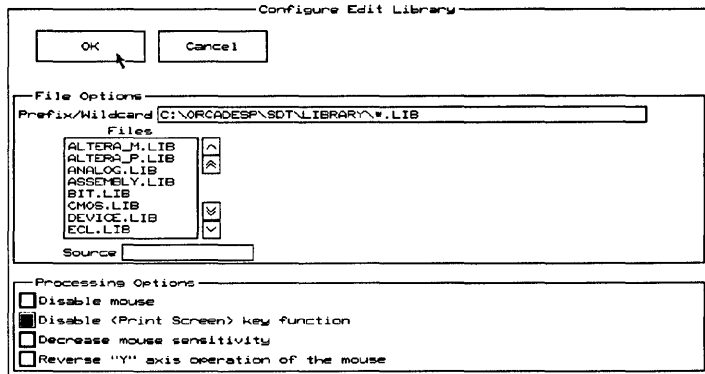

Figure 17-1. Edit Library's local configuration screen.

**File Options** File Options defines a library for Edit Library to open.

*Prefix/Wildcard* Enter a pathname and wildcard to indicate which files to display in the list box with scroll buttons. The asterisk character (\*) is used as a wildcard.

The default is:

```
\ORCADESP\SDT\LIBRARY\*.LIB
```

If you erase the entire field, the entry will be restored to whatever prefix is specified in **Configure Schematic Design Tools**.

*List box with scroll buttons*

The files that match the search filter entered in the **Prefix/Wildcard** entry box and those that match the filter in the current design directory are listed in this box. Files in the current directory are shown with **.\** before their names. Use the scroll buttons to scroll the list of libraries up and down.

When you see the library you would like to edit, click on it to select it. Its path and filename display in the **Source** entry box.

*Source*

The **Source** names a library file. The file can already exist, or you can enter a name for a new library here.

Specify **Source** by selecting a name from the list box, or enter a new name by simply typing it in this entry box and pressing <Enter>.



**NOTE:** A question mark (?) in an entry box tells ESP to default to the **Startup Design** name. This simplifies changing between designs: all you need do is change the **Startup Design** on the **Configure ESP** screen, exit ESP, then restart ESP by entering **ORCAD**.

For example, if you enter **?.LIB** in the **Source** entry box and the **Startup Design** is configured as "TUTOR," the next time you look at the local configuration, the **Source** entry box will be configured as "TUTOR.LIB." If you then change the **Startup Design** to "DESIGN2" and restart ESP, the **Source** entry box will be configured as "DESIGN2.LIB."

**Processing Options** You may select any combination of the following options:

- Disable mouse

Disables the mouse. This option is normally used when attempting to debug mouse problems while working with OrCAD Technical Support. It may also be required when running on older PC-compatible systems.

- Disable <Print Screen> key function

Disables Edit Library's <Print Screen> key function. Use this option when you run other applications (usually RAM-resident) that make use of the <Print Screen> key. If this option is *not* selected, Edit Library uses the <Print Screen> key to capture hardcopy output and blocks other uses.

- Decrease mouse sensitivity

Slows the mouse down. Used for mouse devices that are too sensitive. For example, if you move your mouse a small distance and the pointer moves a large distance on the screen, select this option to make the pointer movement respond more closely to the mouse movement.

- Reverse "Y" axis operation of mouse

Changes the way the mouse responds. If this option is selected, the pointer moves up when you pull the mouse toward you, and moves down when you push the mouse away from you.



## Command reference

The remainder of this chapter is a command reference for **Edit Library**, the graphical parts editor. Commands are described in the order in which they appear in **Edit Library's** main menu.

Many commands in the main menu display other menus. The name of each main menu command appears at the top of the first page describing the command. Any other commands displayed by the main menu command are described with the main menu command.

You can find the description of a particular command two ways:

- ❖ If you know the main menu command that causes the command to appear, skim the pages describing the main menu command until you find the heading for the command below it.
- ❖ Look in the table of contents.

Some commands in the main menu also appear in several other menus. These commands (such as **FIND**, **JUMP**, and **ZOOM**) are described at the main menu level only. When a command occurs in another menu, see the main menu level description of the command for an explanation of its use.

Press the <Esc> key or click the right mouse button at any time to back out of a menu.

## Selecting commands

Select **Edit Library** commands in one of two ways:

- ❖ Press the first letter of the command name. Do this when the command displays in a menu or in a command line at the top of the screen. Main menu commands can also be selected in this way when no menu displays. Occasionally a menu will have more than one command beginning with the same letter. When this happens, use the method of selecting commands explained below.
- ❖ Move the highlighted bar over the command name (using either the mouse or the arrow keys) and press <Enter> or click the left mouse button.

---

## AGAIN

**AGAIN** repeats the last *main menu* command executed. For example, if the last command you selected is **BODY**, you may repeat **BODY** by selecting **AGAIN**.

**AGAIN** does not repeat commands from menus below the main menu. For example, if you execute a command in the **BODY** menu and then select **AGAIN**, the **BODY** menu displays, ready for you to select another **BODY** command.

## BODY

**BODY** displays a menu used for drawing a part. Depending on previous settings, the **BODY** command displays one of three menus: the **Block**, **Graphic**, or **IEEE** menu (figure 17-2).

| BODY <Block> | BODY <Graphic> | BODY <IEEE>  |
|--------------|----------------|--------------|
| Size of Body | Line           | Line         |
| Kind of Part | Circle         | Circle       |
|              | Arc            | Text         |
|              | Text           | IEEE Symbol  |
|              | IEEE Symbol    | Delete       |
|              | Fill           | Erase Body   |
|              | Delete         | Size of Body |
|              | Erase Body     | Kind of Part |
|              | Size of Body   |              |
|              | Kind of Part   |              |

Figure 17-2. BODY's Block, Graphic and IEEE menus.

You cannot mix the different types of objects. A part must be a block, a graphic, or an IEEE part. It cannot be a combination of any of these.

- ❖ A block part is one whose body is a square or rectangle. For example, a JK flip-flop is a Block part. A block part can be up to 12.7 inches by 12.7 inches.

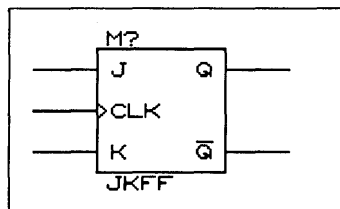

- ❖ A graphic part is one whose body contains graphical information such as circles, arcs, and filled areas. It may also contain lines and text. A graphic part can be a simple square or rectangle, or it can be something more complex, such as an OR gate. A graphic part has no visible pin names.

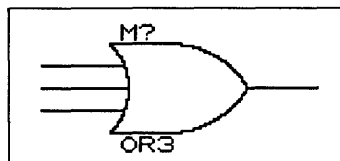

If your part is larger than 1.2 inches by 1.2 inches, it must be drawn as an IEEE part (rather than a graphic part). However, if a graphic part's X axis is less than

1.2 inches, its Y axis can be larger than 1.2 inches, and vice versa. Think of it as a rubber band . . . if you stretch it in one direction, it thins out in the other.

- ❖ An IEEE is one that complies with the ANSI/IEEE standard.<sup>2</sup> IEEE parts differ from graphic parts in that they may not contain arcs or fills, and they are typically larger. You must always create an IEEE part (rather than a graphic part) if the part will be larger than 1.2 by 1.2 inches. An IEEE part can be up to 12.7 by 12.7 inches.

An example of an  
IEEE part

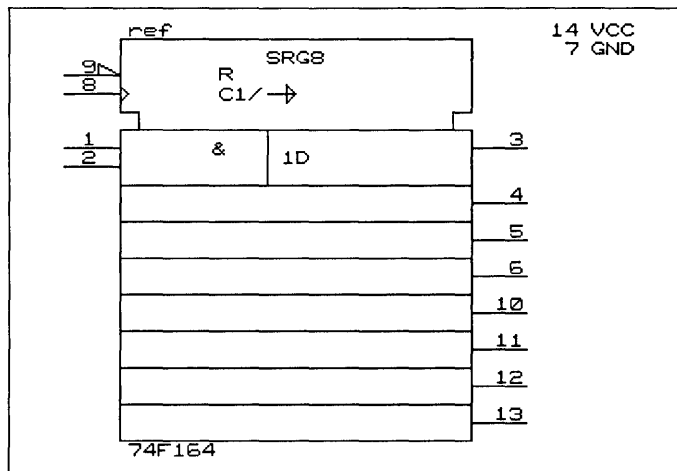

△ **NOTE:** If **Block**, **Graphic**, or **IEEE** was not previously specified, **Edit Library** requests the kind of part as described below. Depending on whether you select **Block**, **Graphic**, or **IEEE**, different questions are asked. These questions are described on the next page.

**BODY Kind of Part?**

The first time you select **BODY**, the menu shown at the right displays. You must tell **Edit Library** which type of part you want to edit. Select **Block**, **Graphic**, or **IEEE**.

Kind of Part?

Block  
Graphic  
IEEE

<sup>2</sup> See ANSI/IEEE Std 91-1984: *IEEE Standard Graphic Symbols for Logic Functions*, ©1984, or *Graphic Symbols for Electrical and Electronics Diagrams*, ©1975; both published by The Institute of Electrical and Electronics Engineers, Inc.

|   |  |
|---|--|
| <b>BODY Kind of Part?</b><br><b>Block</b>   | A block part is one whose body is a square or rectangle. For example, a JK flip-flop is a block part.  |
| <i>Number of Parts per Package</i>          | If you choose <b>Block</b> , <b>Edit Library</b> requests the number of parts per package. Choose a number from <b>0</b> to <b>16</b> .  |
| <i>Is Part a GRID ARRAY?</i>                | This displays only if the number of parts per package is 1. Select <b>No</b> or <b>Yes</b> .<br><br>The <b>Place</b> command displays (described on the next page).  |
| <b>BODY Kind of Part?</b><br><b>Graphic</b> | A graphic part is one whose body contains curves or arcs. For example, an OR gate is a graphic part.   |
| <i>Number of Parts per Package</i>          | If you choose <b>Graphic</b> , <b>Edit Library</b> requests the number of parts per package. Choose a number from 0 to 16.   |
| <i>Does Graphic Part have CONVERT?</i>      | Select <b>Yes</b> or <b>No</b> : <ul style="list-style-type: none"><li>❖ If you choose <b>Yes</b>, <b>Edit Library</b> can assign a <i>converted form</i> for your part (a <i>converted form</i> is used to store a DeMorgan equivalent symbol of the part). It is the version of the part that appears when you issue <b>Draft's GET Convert</b> command.</li><li>❖ If you choose <b>No</b>, <b>Edit Library</b> does not create or store a converted form of the part.</li></ul> The <b>Place</b> command displays (described on the next page). |
| <b>BODY Kind of Part?</b><br><b>IEEE</b>    | An IEEE part is one that complies with the ANSI/IEEE standard. IEEE parts differ from graphic parts in that they may not contain arcs or fills, and they are typically larger.<br><br>If you choose <b>IEEE</b> , <b>Edit Library</b> displays the <b>Place</b> command (described on the next page).  |

**Place** Once you have selected **Block**, **Graphic**, or **IEEE**, and responded to any prompts that display (as described on the previous page), the following command displays:

|       |
|-------|
| Place |
|-------|

To increase or decrease the part size, move the pointer. When the part size is what you want, select **Place**. **Edit Library** fixes the size of the part and displays the appropriate menu, as shown in figure 17-2.

If **SET Show Body** is turned on, a solid line represents vector-drawn parts (**IEEE** and **Block**), and a dashed line indicates a bit-mapped part (**Graphic** or **IEEE**).

Once you have defined the part body, use the displayed menu to place objects on the part, thereby building the part.

For most parts, you should place objects inside the part body. For **Graphic** parts, only the area within the body displays in **Draft**. It is possible for objects such as circles to be placed so that they are partially outside the body. These will usually appear different on a plot. For example, the plotter often draws the entire circle.

For **IEEE** parts, some objects have to be placed outside the body. In particular, the **Active\_Low IN** and **OUT** symbols are normally placed on pins outside the body. Most objects should be inside the body in order to conform to the **IEEE** standard.

**BODY command reference** In the following command reference, the **BODY <Block>** commands are described first, followed by the **BODY <Graphic>** commands, and finally by the **BODY <IEEE>** commands.

**BODY <Block> commands** The **BODY <Block>** command are shown at the right. Descriptions of each of the commands on this menu follow.

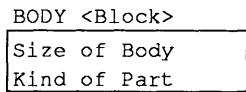

*Body <Block>*  
*Size of Body* Use the **Size of Body** command to change the size of the edited part. To increase or decrease the part size, move the pointer. When the part size is what you want, select **Place**. The **BODY <Block>** menu displays (shown above).

*Body <Block>*  
*Kind of Part* If you want to draw a different type of part, select **Kind of Part**. **Edit Library** displays:

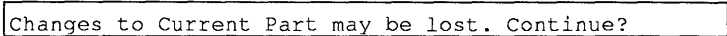

Select **Yes**. The menu shown at right displays. Select the type of part to draw, as described previously in this section.

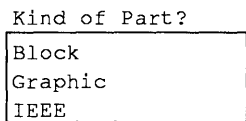

**BODY <Graphic>  
commands**

The **BODY <Graphic>** commands are shown at the right. Descriptions of the commands on this menu follow.

BODY <Graphic>

Line  
Circle  
Arc  
Text  
IEEE Symbol  
Fill  
Delete  
Erase Body  
Size of Body  
Kind of Part

*BODY <Graphic> Line*

Use the **Line** command to draw lines. This command is similar to the **PLACE Wire** command in **Draft**. When you select **Line**, the following command line displays:

Begin Jump Origin Tag Zoom

To draw a line, select **Begin**. This command line displays:

Begin End New Jump Origin Tag Zoom

Drag the pointer to draw the line. To continue or complete the line, select **Begin**, **End**, or **New**.

*Begin*

Ends the current line and begins a new line where the previous line ended.

*End*

Ends the current line and displays the **BODY <Graphic>** menu.

*New*

Ends the current line. You can begin a new line at a different location with **Begin**.



**BODY <Graphic> Circle**

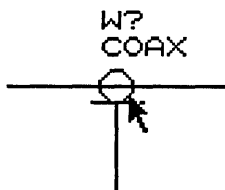

Use the **Circle** command to place a circle within the part outline. When you select **Circle**, the following command line displays:

```
Center Jump Origin Tag Zoom
```

To place a circle, move the pointer to the point that will be the center of the circle. Select **Center**. The following command line displays:

```
Edge Jump Origin Tag Zoom
```

Move the pointer. As you do this, a circle expands and contracts.

△ **NOTE:** Press <Esc> from the **Edge** command line to discard the circle and return to the **Circle** command line.

Move the pointer to where you want the edge of the circle to be and select **Edge**. You have now placed a circle. The **Circle** command line displays.

△ **NOTE:** Circles may appear elliptical on your screen, depending on the type of monitor you have, because of variations between monitors. They will print or plot correctly, though.

BODY <Graphic> Arc



Use the **Arc** command to place an arc within the part outline. An arc is a section of a circle. With **Arc** , you can draw an arc ranging from 0 to 90 degrees. When you select **Arc**, the **Arc** command line displays:

```
Center Jump Origin Tag Zoom
```

This command line is identical to the **Circle** command line.

To place an arc, move the pointer to the center of the circle from which the arc is to be taken. Then, select **Center**. The following command line displays:

```
Edge Jump Origin Tag Zoom
```

This command line is identical to the **Edge** command line appearing under **Circle**.

Move the pointer. As you do this, a circle expands and contracts. A radius extends from the center of the circle to the pointer. Move the pointer to where you want one end of the arc and select **Edge**. Then, move the pointer to where you want the other end of the arc.

Note that you can only move within a quadrant. (A circle is divided into four quadrants by horizontal and vertical lines through the center. Each quadrant is 90 degrees.)

△ **NOTE:** Press <Esc> from the **Edge** command line to discard the arc and return to the **Arc** command line.

Select **Edge** again. You have now placed an arc. The **Arc** command line displays.

△ **NOTE:** For finer control when drawing an arc, zoom in to ½ or ¼ scale.

BODY <Graphic> Text

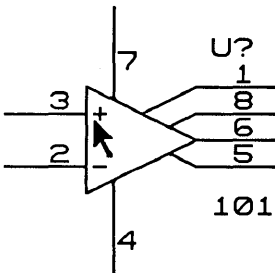

Use the **Text** command to place text within the part outline. The text is a comment. It is not intended to be a reference designator for the part or a name for a pin.

When you select **Text**, the following prompt appears:

Text?

Enter the comment text. The text appears at the pointer position. The command line shown below displays:

Place Larger Smaller Jump Origin Tag Zoom

Select **Larger** to make the text larger and **Smaller** to make it smaller. Move the pointer to the position where you want the text.

Select **Place** to place the text. The "Text?" prompt reappears, ready for you to enter another text item.



***NOTE:** Although you can place text to identify a pin, Schematic Design Tools does not recognize the text as a pin definition. You may wish to use **Text** to make the pin names visible on graphic parts. If you do this, the text will rotate and mirror with the graphic image.*

You should normally place the text within the part outline. However, it is sometimes necessary to place text for IEEE parts outside the outline. If you do this, you run the risk of a messy or ambiguous situation on the final worksheet. If you can't see the part outline, set the **SET Show Body Outline** command to **Yes**. The part outline then displays as a dotted line on the screen. **SET Show Body Outline** is described later in this chapter.

**BODY <Graphic>**  
**IEEE Symbol**

Use the **IEEE Symbol** command to place IEEE/ANSI special symbols within the part outline. For more information about what these symbols mean, see *ANSI/IEEE Std 91-1984*.

When you select **IEEE Symbol**, a menu listing IEEE symbols appears. This menu and the menus its commands display are shown in figure 17-3. Figure 17-3 also shows the IEEE symbols placed by each menu command.

△ **NOTE: Edit Library** treats the negation symbol as a circle. That means a Negation symbol counts toward the maximum number of circles allowed in a part definition.

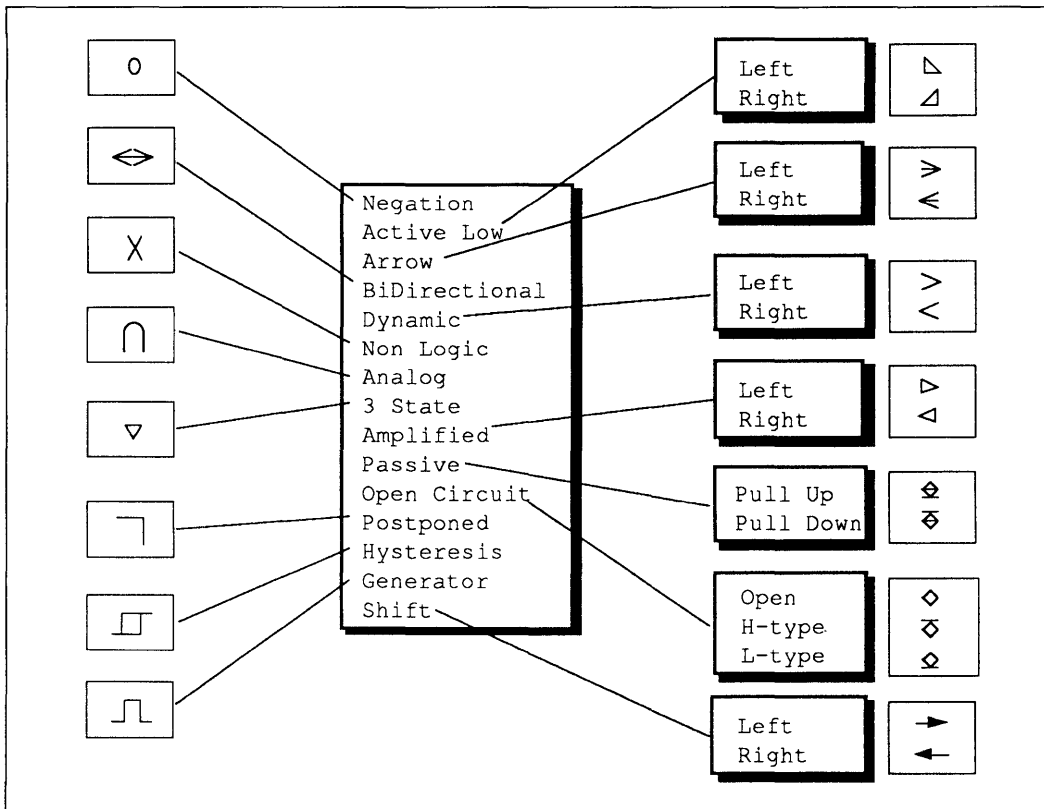

Figure 17-3. IEEE menus and symbols.

Select the name of the symbol to include in your part. If another menu displays, click on the desired selection.

The **Place** command line displays:

Place Larger Smaller Jump Origin Tag Zoom

This command line is identical to the **Text** command line.

Select **Larger** to make the symbol larger and **Smaller** to make it smaller. Move the pointer to the position where you want the symbol. Select **Place** to place the symbol. You can place copies of the symbol as many times as desired. When you are done placing the symbol, select <Esc>. The **IEEE Symbol** menu displays (see figure 17-2).

△ *NOTE: In Edit Library, when the zoom scale is 1, you may not easily distinguish between a pointer position actually on an item and a pointer position just close to a graphic item. When you zoom in, you may place objects in positions that are off grid points. At zoom scale 1, you may not be able to place the pointer on the object because the pointer stays on grid points at this scale. If so, zoom in once or twice to get the fine control needed.*

**BODY** <Graphic> **Fill**



Use the **Fill** command to shade an enclosed area around the current pointer position. For example, **Fill** can be used to darken the triangular shape in the symbol of a diode.

Select **Fill** and the following command line displays:

Fill Jump Origin Tag Zoom

To darken an enclosed area, move the pointer inside the area and then select **Fill** from this menu.

△ *NOTE: If you edit a part after using Fill, you lose your fills. This protects against overflowing the entire part with a fill if you delete the fill boundary. Therefore, use Fill at the end of your editing session.*

**BODY <Graphic> Delete** Use the **Delete** command to delete an item.

▲ **CAUTION:** *Be careful when deleting an item; you cannot undo the deletion.*

Select **Delete** and the following command line displays:

Delete Jump Origin Tag Zoom

To delete an item, place the pointer on the item and select **Delete**. For the item to be deleted, the pointer must actually be on a pixel in the part.

**BODY <Graphic> Erase Body** Use the **Erase Body** command to delete all objects within a part's graphic body. Use this command when you want to start over drawing the graphic body.

When you select **Erase Body**, **Edit Library** asks you to confirm your choice. Select **Yes** to delete the graphic body. Select **No** to return to the **BODY** menu.

**BODY <Graphic> Size of Body** Use the **Size of Body** command to change the size of the part being edited. To increase or decrease the part size, move the pointer. When the part size is what you want, select **Place**. The **BODY <Graphic>** menu displays.

▲ **CAUTION:** *Once objects are inside the body of the part, changing the size of the body can have undesirable results.*

**BODY <Graphic> Kind of Part** To draw a different type of part, select **Kind of Part**. **Edit Library** displays:

Changes to Current Part may be lost. Continue?

Select **Yes**. The menu shown at right displays. Select the type of part to draw, as described previously in this section.

Kind of Part?

Block  
Graphic  
IEEE

**BODY <IEEE>  
commands**

The **BODY <IEEE>** commands are shown at the right. Descriptions of each of the commands on this menu follow.

Body <IEEE>

- Line
- Circle
- Text
- IEEE Symbol
- Delete
- Erase Body
- Size of Body
- Kind of Part

**BODY <IEEE>  
Line**

Use the **Line** command to draw lines. This command is similar to the **PLACE Wire** command in **Draft**. When you select **Line**, the following command line displays:

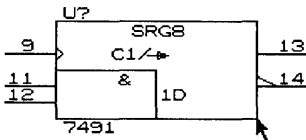

Begin Jump Origin Tag Zoom

To draw a line, select **Begin**. This command line displays:

Begin End New Jump Origin Tag Zoom

Drag the pointer to draw a line. To continue or complete the line, select **Begin**, **End**, or **New**.

*Begin*

Ends the current line and begins a new line where the previous line ended.

*End*

Ends the current line and displays the **BODY <IEEE>** menu.

*New*

Ends the current line. You can begin a new line at a different location with **Begin**.

*BODY <IEEE>*  
*Circle*

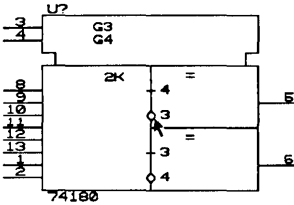

Use the **Circle** command to place a circle. When you select **Circle**, the **Circle** command line displays:

Center Jump Origin Tag Zoom

To place a circle, move the pointer to the point that will be the center of the circle. Select **Center**. The following command line displays:

Edge Jump Origin Tag Zoom

Move the pointer. As you do this, a circle expands and contracts.



*NOTE: Press <Esc> from the **Edge** command line to discard the circle and return to the **Circle** command line.*

Move the pointer to where you want the edge of the circle to be and select **Edge**. You have now placed a circle. The **Circle** command line displays.



**BODY <IEEE>**  
*Text*

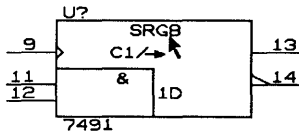

Use the **Text** command to place text within the part outline or near the part. The text is a comment. It is not intended to be a reference designator for the part or a name for a pin.

When you select **Text**, the following prompt appears:

Text?

Enter the comment text. The text appears at the pointer position. The command line shown below displays:

Place Larger Smaller Jump Origin Tag Zoom

Select **Larger** to make the text larger and **Smaller** to make it smaller. Move the pointer to the position where you want the text.

△ **NOTE:** *IEEE text is limited to ten characters per text object. If you enter more than ten characters in response to the "Text?" prompt, the extra characters are discarded. You can place two or more text objects together to create a string that is longer than ten characters.*

Most of the time, you place the text within the part outline. It is sometimes necessary, however, to place text for IEEE parts *outside* the outline. If you do this, you risk a possibly messy or ambiguous situation later on the schematic worksheet. If you can't see the part outline, set the **SET Show Body Outline** command to **Yes**. The part outline then displays as a dotted line on the screen. **SET Show Body Outline** is described later in this chapter.

Select **Place** to place the text. The "Text?" prompt reappears, ready for you to enter another text item.

△ **NOTE:** *Although you can place text to identify a pin, Schematic Design Tools does not recognize the text as a pin definition. You may wish to use **Text** to make the pin names visible on graphic parts. If you do this, the text will rotate and mirror with the graphic image.*

**BODY <IEEE>**  
**IEEE Symbol**

Use the **IEEE Symbol** command to place IEEE/ANSI special symbols. For more information about what these symbols mean, see *ANSI/IEEE Std 91-1984*.<sup>3</sup>

When you select **IEEE Symbol**, a menu listing IEEE symbols appears. This menu and the menus it displays are shown in figure 17-3.

Select the name of the symbol to include in your part. If another menu displays, make an appropriate selection.

The **Place** command line displays:

```
Place Larger Smaller Jump Origin Tag Zoom
```

Use **Larger** and **Smaller** to change the size of the symbol. Move the pointer to the position where you want the symbol and select **Place**. You can place copies of the symbol as many times as desired. When you are done, press <Esc>. The **IEEE Symbol** menu (figure 17-2) displays.

The current size specified by **Larger** or **Smaller** affects both IEEE symbols and text. The size retains its last setting, so you can place objects at the same relative scale.

**BODY <IEEE> Delete**

Use the **Delete** command to delete an item.



**CAUTION:** Be careful when deleting an item; you cannot undo the deletion.

When you select **Delete**, this commandline displays:

```
Delete Jump Origin Tag Zoom
```

To delete an item, place the pointer on the item and select **Delete**. For the item to be deleted, the pointer must actually be on a pixel in the part.

Note that at Zoom scale 1, it's not easy to distinguish between a pointer position actually on an item and a pointer position just close to a graphic item.

<sup>3</sup> See ANSI/IEEE Std 91-1984: *IEEE Standard Graphic Symbols for Logic Functions*, © 1984, or *Graphic Symbols for Electrical and Electronics Diagrams*, © 1975; both published by The Institute of Electrical and Electronics Engineers, Inc.

**BODY <IEEE>**  
*Erase Body*

Use the **Erase Body** command to delete all lines, circles, IEEE symbols, and comment text associated with a part. Use **Erase Body** when you want to start over drawing the body.

When you select **Erase Body**, **Edit Library** asks you to confirm your choice. Select **Yes** to delete the graphic body. Select **No** to return to the **BODY** menu.

**BODY <IEEE>**  
*Size of Body*

Use the **Size of Body** command to change the size of the part being edited. To increase or decrease the part size, move the pointer. When the part size is what you want, select **Place**. The **BODY <IEEE>** menu displays.

▲ **CAUTION:** *Once objects are in the body of the part, changes to its body size can have undesirable results.*

**BODY <IEEE>**  
*Kind of Part*

To draw a different type of part, select **Kind of Part**. **Edit Library** displays:

Changes to Current Part may be lost. Continue?

Select **Yes**. The **Kind of Part?** menu displays. Select the type of part to draw, as described earlier in this section.

## CONDITIONS

**CONDITIONS** monitors your computer's memory, and the memory available for the worksheet, hierarchy buffer, and macro buffer. When you select **CONDITIONS**, a status window displays (figure 2-2). The **CONDITIONS** status window does *not* respond to mouse commands. Press any key to return to the main menu level.

You can print a copy of the **CONDITIONS** status window by pressing <Print Screen>. Make sure the **Disable <Print Screen> key function option on Edit Library's** local configuration screen is not selected.

The types of information **CONDITIONS** displays are described below.

**No Parts** If there are no parts currently displayed on the screen, information similar to the following displays:

```

Press Enter to continue ■
CONDITIONS:

```

|                               | Allocated | Used  | Available |
|-------------------------------|-----------|-------|-----------|
| Macro Buffer                  | 8192      | 0     | 8192      |
| Free System Memory            | -----     | ----- | 35648     |
| Library                       |           |       |           |
| Objects                       | 1023      | 0     | 1023      |
| General Control Information   | 65520     | 0     | 65520     |
| Bit Map Images                | 65520     | 0     | 65520     |
| Vectors (Circles, Lines, etc) | 65520     | 0     | 65520     |

Figure 17-4. **CONDITONS** status window.

△ **NOTE:** The numeric values displayed on the **CONDITIONS** screen vary with the content of the libraries and the work in progress.

Notice that for each item listed, **Edit Library** shows the amount of memory allocated, the amount of memory used, and the amount of memory still available. The amount of memory allocated to any given item is specified on the **Schematic Design Tools Configuration** screen. See *Chapter 1: Configure Schematic Tools* for information on how to configure these items.

|  |  |
|--|--|
| <i>Macro Buffer</i>                          | This shows the amount of memory available in the macro buffer. The buffer contains user-created macros—both those created on line and loaded from a macro file.  |
| <i>Free System Memory</i>                    | This shows how much unused memory remains in your computer.  |
| <i>Library Objects</i>                       | This tells how many names you can add to the current library. A library can have up to 1023 names (more if you use prefixes). Note the number represents names, not parts. Also, a part may have multiple names. However, extra names resulting from prefix definitions do not count. For more information about prefix definitions, see <i>Chapter 14: About Libraries</i> in this guide. |
| <i>Library General Control Information</i>   | This shows the number of bytes available for additional library symbols. <b>General Control Information</b> symbols include part names, pin names, pin positions, block symbols, and so on.  |
| <i>Library Bit Map Images</i>                | This shows the number of bytes available for additional library bitmaps. When you make a part with <b>Edit Library</b> , you use vectors. However, bitmaps are needed for screen work. For example, <b>Draft</b> requires a bitmap to display a graphic part. Consequently, when you add a graphic part to a library, a bitmap version is stored as well as a vector version.              |
| <i>Library Vectors (Circles, Lines, etc)</i> | This shows the number of bytes available for additional library vectors. <b>Edit Library</b> vectors include lines, circles, arcs, IEEE symbols, text, and files.  |

---

**EXPORT**

**EXPORT** writes the current part definition (the one being edited) to a file. The file is called an export file and is formatted as a library source file without a PREFIX-END statement. **EXPORT** writes only one part per export file.

To add the part in the export file to an existing library, run **Edit Library** and specify the desired destination library as the current library. Then, use the **IMPORT** command to read the export file. You can then make changes to the part using **Edit Library** commands if necessary. Then, you can add the part to the library with the **LIBRARY Update Current** command.

△ ***NOTE:** A part must have a name before you can write it to an export file. Use the **NAME** command to give the part a name.*

**Example** To modify a part from TTL.LIB, and write it to a new file, follow these steps:

1. In **Edit Library's Local Configuration** screen, configure **Source** to be the library from which you will copy the part—in this case, TTL.LIB.
2. Execute **Edit Library**.
3. Select **GET PART** from the main menu. **Edit Library** displays the prompt:

Get?

4. Enter the name of the part, or press <Enter> to see a menu of parts to select from. The selected part displays on the screen.
5. Now, select **EXPORT**. **Edit Library** displays the prompt:

Export to?

6. Enter the name of a temporary file for the data to be stored—in this case, TEMP.

△ **NOTE:** *The temporary file created by exporting a part from Edit Library is not yet a library file. It is only a data file used by Edit Library, when you import the data, to create a library file.*

7. Select **QUIT Initialize**. Edit Library prompts:

Read Library?

8. Enter the new library name.
9. Now, import the data from the temporary file. Select **IMPORT**. Edit Library prompts:

Import From?

10. Enter the name of the temporary data file in which you stored the exported data—in this case, TEMP.

The part is now ready for you to edit. When you have completed your editing, save the new library as follows:

1. Select **LIBRARY Update Current**. This modifies the copy of the library in memory, **NOT** the copy on disk.
2. Now, select **QUIT Update File**. This writes the latest copy of the library from memory to disk.
3. Select **Abandon Edits**.

---

**GET PART**

**GET PART** retrieves a part from a library for editing. There are two methods you can use to retrieve parts.

| <i>Method 1</i>   | <i>Method 2</i>   |
|---|---|
| <p>Select <b>GET PART. Edit Library</b> displays "Get ?"</p> <p>Enter the desired part name exactly as it appears in the library directory. <b>Edit Library</b> searches the library you specified when you configured <b>Edit Library</b> and finds the part you requested. Once it finds the part, <b>Edit Library</b> displays it on the screen.</p> <p>To verify the spelling of a part name, use the <b>LIBRARY Directory</b> command.</p> | <p>Select <b>GET PART. Edit Library</b> displays "Get ?"</p> <p>Press &lt;Enter&gt;. <b>Edit Library</b> displays a menu listing the library parts. Move the highlight to the part name you want, then press &lt;Enter&gt; to retrieve the part. <b>Edit Library</b> displays the part on the screen.</p> |

**Getting a part by entering a part suffix**

If you are using Method 1 (as described above), you can select library part numbers created with a prefix and shorthand string (see *Prefix definition* in *Chapter 14: About Libraries*) from the library by entering the suffix. For example, suppose you want to retrieve a 74LS27 from the TTL.LIB library. After selecting **GET**, enter any of the following examples to retrieve the part:

- Get?**      The entire part name is used to retrieve the  
74LS27      part.
- Get?**      The prefix "LS" (which is the shorthand  
LS27      string for "74LS") is combined with the suffix  
             "27." **Edit Library** retrieves the part 74LS27.
- Get?**      **Edit Library** lists all parts in the library that  
27      have "27" in their names. Select the 74LS27  
             from the menu that displays the part names.  
             **Edit Library** retrieves the part 74LS27.



## IMPORT

**IMPORT** reads a part from an export file created with the **EXPORT** command. Export files contain only one part definition per file. **IMPORT** reads in the part definition as the current active part. It overwrites the existing current part.

When you select **IMPORT**, the following prompt appears:

Import From?

If you press <Enter> or <Esc> without entering a filename, **Edit Library** returns to the main menu.

△ ***NOTE:** If you made any changes to the current part since the last **GET** or **LIBRARY Update**, a message displays that warns you about losing your changes. Select **No** or press <Esc> to cancel the *Import* command.*

## JUMP

Use **JUMP** to quickly move the pointer to a different location in your work area. The specific locations can be tags or (X,Y) coordinates. When you select **JUMP**, the commands shown in the figure at the right appear.

Jump

|            |
|------------|
| A tag      |
| B tag      |
| C tag      |
| D tag      |
| E tag      |
| F tag      |
| G tag      |
| H tag      |
| X location |
| Y location |

### JUMP A, B, C, D, E, F, G, H Tag

When you select one of the **JUMP Tag** commands, the pointer jumps to the specified tag on the drawing (the tag must have been previously set with the **TAG** command). For information on the **TAG** command, see the *Tag* section in this chapter.



**NOTE:** The error message "Tag does not exist" displays if the specified tag has not been set.

### JUMP X-Location

The **X-Location** command moves the pointer a specific distance along the X-axis. Each step represents  $\frac{1}{100}$  (0.01) inch on the worksheet (if the pin-to-pin spacing on the template table in the **Configure Schematic Design Tools** screen is set to the default value of 0.100 inch).

To jump to an X-location, follow these steps.

1. Select **JUMP X-Location**.
2. **Edit Library** displays "Jump X". Enter the number of steps to jump. A number without a plus or minus sign moves the pointer to the actual grid coordinate, a signed positive number (+10, +25, +30, and so on) moves the pointer to the right, and a negative number (-10, -25, -30, and so on) to the left. If you enter +10, for example, the pointer jumps to the right 1 inch. If you enter 10, without a plus or minus sign, the pointer moves to the actual X grid coordinate 10.0.

When you press <Enter>, the pointer jumps to the specified grid reference location and **Edit Library** returns to the main menu level.

### **JUMP Y-Location**

The **Y-Location** command moves the pointer a specific distance along the Y-axis. Each step represents  $\frac{1}{100}$  (0.01) inch on the worksheet. If the pin-to-pin spacing on the template table on the **Configure Schematic Design Tools** screen is set to the default value of 0.100 inch (if the pin-to-pin spacing on the template table on the **Configure Schematic Design Tools** screen is set to the default value of 0.100 inch).

To jump to a Y-location, follow these steps.

1. Select **Y-Location**.
2. **Edit Library** displays "Jump Y". Enter the number of steps to jump. A number without a plus or minus sign moves the pointer to the actual grid coordinate, a signed positive number (+10, +25, +30, and so on) moves the pointer up, and a negative number (-10, -25, -30, and so on) down. If you enter +10, for example, the pointer jumps up 1 inch. If you enter 100, without a plus or minus sign, the pointer moves to the actual Y grid coordinate 10.0.

When you press <Enter>, the pointer jumps to the specified location and **Edit Library** returns to the main menu level.

△ *NOTE: The coordinates used by the **JUMP X-Location** and **JUMP Y-Location** commands are independent of the origin set with the **ORIGIN** command. When using **JUMP X-Location** and **JUMP Y-Location** the origin is always 0.0.*

---

## **LIBRARY**

**LIBRARY** updates the current library, lists the part names in the library, browses through the library, deletes a part from the library, and defines prefixes.

When you select the **LIBRARY** command, the menu shown at right appears.

| <i>Library filename</i> |
|-------------------------|
| Update Current          |
| List Directory          |
| Browse                  |
| Delete Part             |
| Prefix                  |

### **LIBRARY** **Update Current**

Updating the library means either changing the definition of an existing part or adding a new part.

To change the definition of an existing part, retrieve the part with the **GET PART** command, edit it, and then select **LIBRARY Update Current**.

To add a new part, build the part (you may find it easier to retrieve a similar part and edit it), name the part with the **NAME** command, and select **Update Current**.

Updating the library with the **Update Current** command modifies the copy of the library in memory, *not* the copy on disk. To change the copy of the library on disk, use the **QUIT Update**

**File** command (which saves the library on disk without renaming it) or the **QUIT Write to File** command (which saves the library on disk under a new name).

|                |  |
|----------------|--|
| Work area      | <p><b>Edit Part</b> keeps the part you are working on in a temporary memory location.</p> <p>Using the <b>LIBRARY Update Current</b> command moves the part from the temporary work area to this buffer.</p> <p>Using the <b>QUIT Update File</b> command writes the contents of the buffer to disk.</p> |
| Library buffer |  |
| Disk storage   |  |

**LIBRARY** List Directory lists the names of the parts in a library.  
**List Directory** The list can be displayed, printed, or saved in a file.

Select **List Directory**. **Edit Library** displays the menu shown at the right.

List Directory To?

|         |
|---------|
| Screen  |
| Printer |
| File    |

*Screen* Select **Screen**. The library directory displays on the screen.

*Printer* Select **Printer**. The library directory prints on the printer.

*File* Select **File**. **Edit Library** displays "File?" on the prompt line. Enter the path and filename. The library directory is sent to a file.

| Directory of EXAMPLE.LIB |        |       |       |       |       |       |       |       |       |       |
|--------------------------|--------|-------|-------|-------|-------|-------|-------|-------|-------|-------|
| Prefix -                 | 74LS   | 74S   | 74ALS | 74AS  | 74HCT | 74HC  | 74ACT | 74AC  |       |       |
| Shorthand-               | LS     | S     | ALS   | AS    | HCT   | HC    | ACT   | AC    |       |       |
| Prefix -                 | 74AHCT | 74FCT | 74F   | 74C   | 74    |       |       |       |       |       |
| Shorthand-               | AHCT   | FCT   | F     | C     |       |       |       |       |       |       |
| 00                       | 01     | 02    | 03    | 04    | 05    | 06    | 07    | 08    | 09    | 10    |
| 11                       | 12     | 13    | 14    | 15    | 16    | 17    | 18    | 19    | 20    | 21    |
| 22                       | 24     | 25    | 26    | 27    | 28    | 30    | 32    | 33    | 34    | 35    |
| 36                       | 37     | 38    | 39    | 40    | 41    | 42    | 43    | 44    | 45    | 46    |
| 47                       | 48     | 49    | 50    | 51    | 51X   | 54    | 54X   | 55    | 56    | 57    |
| 60                       | 63     | 64    | 65    | 68    | 69    | 70    | 72    | 73    | 74    | 75    |
| .                        | .      | .     | .     | .     | .     | .     | .     | .     | .     | .     |
| .                        | .      | .     | .     | .     | .     | .     | .     | .     | .     | .     |
| .                        | .      | .     | .     | .     | .     | .     | .     | .     | .     | .     |
| 11241                    | 11244  | 11245 | 11251 | 11253 | 11257 | 11258 | 11280 | 11286 | 11299 | 11323 |
| 11352                    | 11353  | 11373 | 11374 | 11378 | 11379 | 11520 | 11521 | 11533 | 11534 | 11620 |
| 11623                    | 11640  | 11643 | 11646 | 11648 | 11651 | 11652 | 11821 | 11822 | 11823 | 11824 |
| 11825                    | 11826  | 11827 | 11828 | 11833 | 11834 | 11841 | 11842 | 11843 | 11844 | 11845 |
| 11846                    | 11853  | 11854 | 11861 | 11862 | 11881 | 11882 | 29806 | 29809 | 29827 | 29828 |
| 29861                    | 29862  | 29863 | 29864 | 75188 | 75189 |       |       |       |       |       |

Figure 17-5. Partial Listing of EXAMPLE.LIB.

**LIBRARY Browse**

The **Browse** command in **Edit**

**Library** works like the **Browse** command in **Draft**

does. Use it to view the contents of a

library, or select an object and view it on the screen.

Select **Browse**. The menu shown above displays.

Browse

All parts

Specific parts

*All parts*

Select **All parts** to view parts starting at the beginning of the library and proceeding toward the end. The parts are arranged in ascending numeric or alphabetic order. When you select **All parts**, the menu shown above appears.

Select **Forward** or **Backward** to browse through the library. Select **Quit** to return to the main menu. The last part displayed remains on the screen, ready for editing.

Browse

Forward

Backward

Quit

Select **Forward** or **Backward** to browse through the

library. Select **Quit** to return to the main menu. The last part displayed remains on the screen, ready for editing.

*Specific parts*

Select **Specific parts** when you know the name of the part you want to view. When you select **Specific parts**, the "Part?" prompt appears.

If you know the name of the part you want to look at, type its name, then press <Enter>. **Edit Library** gets the part and shows the part on the screen.

If you don't know the part name, press <Enter>. **Edit Library** displays a list of part names. You can then select the desired part from the list.



**NOTE:** Use the <↓> and <↑> keys with the <Enter> key, or the left mouse button to scroll through the list of parts.

When you select a part, the "Part?" prompt returns. You can display another part or a list of part names as described above. If you press <Esc> without a part name, **Edit Library** returns to the main menu level. The last part displayed remains on the screen, ready for editing.

**LIBRARY Delete Part** Use the **Delete Part** command to delete parts from a library. When you select **Delete Part**, the following prompt appears:

Delete Library Part?

To delete a part, type the suffix of the part name and press <Enter>. If you press <Enter> without specifying a part, **Edit Library** displays a list of part names. You can then select the part you want to delete.

The **Delete Part** command only deletes a part from the library in memory. The part is not deleted from the library on disk until you issue the **QUIT Update File** command (saves the modified library to the same file) or **QUIT Write to File** command (saves the modified library to a new file you specify).

If a part definition has multiple names (or suffixes) associated with it, this command only deletes the particular suffix you type. The part is only deleted when the last of its suffixes is deleted.

**LIBRARY Prefix** Use the **Prefix** command to edit a library's prefix definition.

Select **Prefix**. **Edit Library** displays a command line, a list of prefixes, and their associated shorthand:

```
Add Delete Edit Quit

      PREFIX SHORTHAND
      74LS   LS
      74S    S
      74ALS  ALS
      74AS   AS
      74HCT  HCT
      74HC   HC
      74ACT  ACT
      74AC   AC
      74AHCT AHCT
      74FCT  FCT
      74F    F
      74C    C
      74
```

**Draft** uses a library's prefix definition when you get a part with the **GET** command. Instead of entering the long name of a part, you can enter just the part's suffix. For example, if **TTL.LIB** is one of **Schematic Design Tool's** libraries, and you enter the suffix **04**, a menu similar to the one shown at right lists the parts.

The prefix definition is specifically designed to handle the various TTL logic families. For example, the 74LS00, the 74S00, and the 74ALS00 have different prefixes (74LS, 74S, and 74ALS), but the same suffix (00). When you use a prefix definition, you reduce the memory needed to store multiple families of parts that have different prefixes, but the same suffix. For more information, see *Prefix definition* in *Chapter 14: About libraries*.

Get ?

```
74LS04
74S04
74ALS04
74AS04
74HCT04
74HC04
74ACT04
74AC04
74AHCT04
74F04
74C04
7404
```



*Add* To add a prefix to the library, move the highlight to the position where the new prefix will go and then select **Add**. The prompt "Prefix?" appears. Enter the prefix you want to store.

The prompt "Shorthand Prefix?" then appears. Enter the abbreviation you want to use for the part prefix.

The prefix and its shorthand equivalent are added at the location of the highlight.

△ *NOTE: Up to sixteen prefixes can be defined in each library.*

*Delete* To delete a name, place the highlight on the prefix or shorthand name and select **Delete**.

*Edit* To edit an existing prefix or shorthand prefix, place the highlight on the name and select **Edit**. The prompts "Prefix?" or "Shorthand Prefix"? appear followed by the current name. Backspace over the current name and type the new name followed by <Enter>.

*Quit* **Quit** saves your entries or changes and displays the **LIBRARY** menu.

---

**MACRO**

A macro is a set of keystrokes you assign to a particular key. You can run all the commands represented by those keystrokes by pressing just the assigned key. With the **MACRO** command, you can capture keystrokes, delete macros, write defined macros to a file, read macros from a file, list the active macro keys and erase (initialize) the macro file.

**Edit Library's MACRO** command works just like **Draft's MACRO** command. For more information about writing macros, see the description of the **MACRO** command in the *Chapter 2: Draft* in this guide.

To define and load a macro file that loads whenever **Edit Library** runs, enter the filename in the **Edit Library Macro File** entry box on the **Configure Schematic Design Tools** screen.

**Initial Macro** Initial macros run automatically each time you load **Edit Library**. To define and load an initial macro, follow the instructions given in the **MACRO** section of *Chapter 2: Draft*. Enter the initial macro name in the **Edit Library Initial Macro** entry box on the **Configure Schematic Design Tools** screen.

**NAME**

Use **NAME** to assign a name to a part.

When you edit a part from an OrCAD-supplied library, it comes into **Edit Library** with its own name or list of names. If you update the library with the **LIBRARY Update Current** command, you overwrite the existing part.

Suppose you want, instead, to construct a new part. If the part is similar to an existing part, the best way to build it is to read in the existing part, rename the part, edit it, and *then* update the library.

A part may have a list of names. For a part to be unique, each name in the list must be unique. For example, assume you do the following:

- ❖ Retrieve a part with the names A, B, and C.
- ❖ Change one of its names (for example, C to D).
- ❖ Edit the part definition.
- ❖ Add the part (now with names A, B, and D) to the library.

The library now contains two parts: one with the names A, B, and D (the new part) and one with the name C (the old part). Adding a new part replaces existing parts with the same name. Because the new part doesn't have the name C, one instance of the original part is kept with the name C. To delete C from the library, use the **LIBRARY Delete Part** command.

When you select **NAME**, the menu shown at right appears.

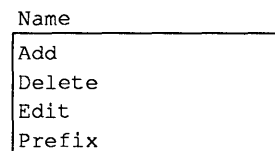

△ **NOTE:** *The maximum length allowed for part names is 127 characters. However, it is recommended that you use much smaller part names. On a 640 x 480 screen at zoom scale 1, a name longer than 78 characters is clipped short. Also, many netlist formats place restrictions on the length of names. Check the name length requirements for the netlist format you are using. This information is available using the **View Reference Material** tool.*

**NAME Add** To add a name to a part, select **Add**. The prompt "Name?" appears. Enter the name to give the part. The prompt "Sheet Path?" then appears. If the part represents a sheet, enter the name of the schematic file. If the part does not represent a sheet, just press <Enter>. For more information about sheet parts, see *Editing sheets* and *PLACE Sheet* in *Chapter 2: Draft* in this guide.

**NAME Delete** To delete a name, select **Delete**. The list of names appears. Select the name to delete.

**NAME Edit** To edit an existing name, select **Edit**. The list of names appears. Select the name you want to edit. The prompt "Name?" appears followed by the current name. Edit the name by positioning the cursor using the <←> and <→> keys and the <Home> and <End> keys. Erase characters with the <Backspace> and <Delete> keys. When you are done editing, press <Enter>.

The prompt "Sheet Path?" then appears. If the part represents a sheet, enter the pathname of the schematic file. If the part does not represent a sheet, just press <Enter>. If the part already has a sheetname, it appears after the prompt and may be edited.

**NAME Prefix** To determine what prefixes are assumed for a part name, select **Prefix**. The list of part names appears. Select the part name whose prefixes you want to determine.

The list of prefix strings defined for the library appears (see right). Beside each prefix string is a **Yes** or a **No**, which determines whether the prefix string is valid or invalid for the selected part name. To change the setting of a prefix string, select the prefix string. Then select **Yes** to make the string valid or **No** to make it invalid.

|        |    |
|--------|----|
| 74LS   | NO |
| 74S    | NO |
| 74ALS  | NO |
| 74AS   | NO |
| 74HCT  | NO |
| 74HC   | NO |
| 74ACT  | NO |
| 74AC   | NO |
| 74AHCT | NO |
| 74FCT  | NO |
| 74F    | NO |
| 74C    | NO |
| 74     | NO |

---

## **ORIGIN**

**ORIGIN** sets the current pointer position as the new X,Y origin (X=0.0, Y=0.0). The default origin is the upper left of the part's body. When building a part, it is sometimes useful to redefine the origin to be at a particular point within the part outline. In this way, you can easily make relative measurements when constructing graphic parts.

---

**PIN**

Use the **PIN** command to add, delete, or edit pins.

Select **PIN. Edit Library** displays:

|     |        |      |            |      |       |      |      |
|-----|--------|------|------------|------|-------|------|------|
| Add | Delete | Name | Pin-Number | Type | Shape | Jump | Zoom |
|-----|--------|------|------------|------|-------|------|------|

**PIN Add** To add a pin to a part, place the pointer where you want the new pin and select **Add. Edit Library** then queries you for the Name, Pin Number, Type (Input, Output, Bidirectional, Power, Passive, 3-state, Open Collector, or Emitter), and Shape (Line, Clock, Dot, Dot Clock, or Short) of the pin you are adding.

These pin attributes are explained below.

**PIN Delete** To delete a pin in a part, place the pointer at the unwanted pin and select **Delete**.

**PIN Name** Use the **Name** command to edit the string definition of an existing pin.

To enter a name with a bar over it (indicating negation), type backslash characters after the letters. For example, type:

```
R\E\S\E\T
```

to define the name:

```
_____  
RESET
```

**PIN Pin-Number** Use the **Pin-Number** command to change the pin number of a pin.

**PIN Type** To change the type of a pin, move the pointer to the pin's location and select **Type**. A menu listing the available pin appears (see right). The pin's current type is shown above the menu.

Pin Type - Input

|                |
|----------------|
| Input          |
| Output         |
| Bidirectional  |
| Power          |
| Passive        |
| 3 State        |
| Open Collector |
| Open Emitter   |

Select the type you want. The available types are described below and on the next page.

*Input* An input pin is one to which you apply a signal. For example, pins 1 and 2 on the 74LS00 NAND gate are input pins.

*Output* An output pin is one to which the part applies a signal. For example, pin 3 on the 74LS00 NAND gate is an output.

*Bidirectional* A bidirectional pin is either an input or an output. For example, pin 2 on the 74LS245 bus transceiver is a bidirectional pin. The value at pin 1 (an input) determines the active type of pin 2 as well as others.

*Power* A power pin expects either supply voltage or ground. For example, on the 74LS00 NAND gate, pin 14 is Vcc, and pin 7 is GND (ground).

△ **NOTE:** Power pins are invisible.

*Passive* A passive pin is typically connected to a passive device. A passive device does not have a source of energy. For example, a resistor lead is a passive pin.

*3 State* A 3-state pin has three possible states: low, high, and high impedance. When it is in its high impedance state, a state pin looks like an open circuit. For example, the 74LS373 latch has 3-state pins.

**Open Collector** An open collector gate omits the collector pull-up. Use an open collector to make “wire-OR” connections between the collectors of several gates and to connect with a single pull-up resistor. For example, pin 1 on the 74LS01 NAND gate is an open collector gate.

**Open Emitter** An open emitter gate omits the emitter pull-up. The proper resistance is added externally. ECL logic uses an open emitter gate and is analogous to an open collector gate. For example, the MC10100 has an open emitter gate.

**PIN Shape** To specify the shape of a pin, move the pointer to the pin location and select **Shape**. A menu listing available pin shapes appears (shown below). The pin’s current shape appears above the menu.

Select the shape you want.

The shape **Line** represents a normal pin with 3 grid unit leads. **Short** represents a pin with 1 grid unit lead.

**Dot** indicates the inversion bubble while **Clock** indicates the clock symbol. The combination **Dot Clock** represents a clock symbol with an inversion bubble.

Pin Shape - Dot

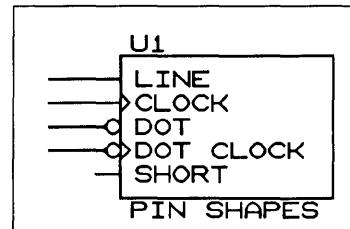
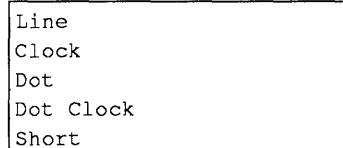

**PIN Move** To move a pin, select **Move**. “Pin to Move?” displays.

Place the pointer on the pin you need to move, and click the mouse button. “New Pin Location?” displays.

Move the pointer to the new location, and click the mouse button once. **Edit Library** places the pin in the new location.



## QUIT

Use the **QUIT** command to leave **Edit Library** and return to the **Schematic Design Tools** screen. With **QUIT**, you can also write to a file, update the current library, initialize the current **Edit Library** session, and suspend to the operating system.

```
Quit LIBRARY.LIB
Update File
Write to File
Initialize
Suspend to System
Abandon Edits
```

When you select **QUIT**, the menu shown above appears.

### QUIT Update File

The **Update File** command writes the latest copy of the library being edited to disk. This command is *not* the same as the **LIBRARY Update Current** command.

The procedure for modifying a library is as follows:

- ❖ Run **Edit Library** using the desired library. **Edit Library** then reads the library into memory.
- ❖ Get and edit a part definition, or define a new part.
- ❖ Select **LIBRARY Update Current** to modify the copy of the library in memory.
- ❖ Select **QUIT Update File** to write the copy of the library in memory to disk.

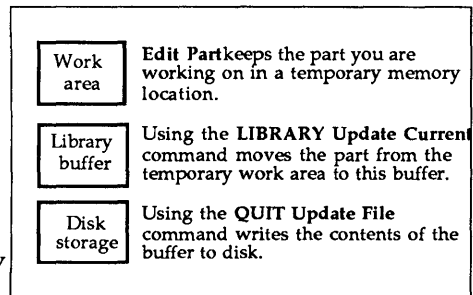

△ **NOTE: QUIT Update File** writes a compiled library file. It does not change any corresponding library source file. To update the library source file to reflect the changes you made with **Edit Library**, run **Decompile Library** on the new compiled library file to make a new source file.

**QUIT Write to File** **Write to File** writes the latest copy of the library being edited to any file you specify. When you select **Write to File**, the following displays:

Write to?

Enter the path and filename you want to write to.

**QUIT Initialize** The **Initialize** command abandons the edits since the last file update. When you select **Initialize**, the current library is removed from memory, and the following prompt appears:

Read library?

Enter the path and filename of the file you want to edit.

△ *NOTE: If you have made changes since the file was loaded or saved, **Edit Library** displays "Initialize - Are you sure?" Select **No** to cancel the **Initialize** command and return to the main menu level. Select **Yes** to allow the initialize command to continue.*

**QUIT Suspend to System** **Suspend to System** temporarily leaves **Edit Library** and the part you are creating and returns to the operating system. Once you have suspended **Edit Library**, you may perform operating system functions, including using other software programs as long as there is enough computer memory.

To suspend to the operating system, select **Suspend to System**. **Edit Library** suspends operation, loads the operating system command interpreter, and adds an additional ">" to the system command prompt. This is a reminder that **Edit Library** is suspended and in the background.

To return to **Edit Library**, type **EXIT** at the operating system prompt. **Edit Library** then comes to the foreground and the part you were working on when you suspended **Edit Library** returns to the screen.

**QUIT Abandon Edits** Use the **Abandon Edits** command to end your **Edit Library** session and return to the **Schematic Design Tools** screen.

If you changed the library currently in memory (with the **LIBRARY Update Current** command), **Abandon Edits** asks you to confirm your decision to leave.

Select **No** to return to the main command level. Select **Yes** to exit **Edit Library**.

---

## REFERENCE

Use **REFERENCE** to define or edit a part's reference designator.

The default reference designator is "U?". The "?" is a placeholder for the number representing the occurrence of the device. The **Annotate Schematic** tool replaces "?" with a number indicating the instance of the part. If the part is a multiple-part package, **Annotate Schematic** adds a one-character alphabetic suffix to the reference designator and increments it A, B, C, and so on, once for each part of the package used.

When you select **REFERENCE**, this prompt appears:

Initial Reference Designator? U

"U" is the current reference designator. To replace U with another letter or sequence of letters and numbers, backspace over U, type the new reference designator, and press <Enter>.

Press <Enter> without typing anything to return to the main menu level.

△ **NOTE:** *If a part is zero parts per package and you delete the "?," the reference designator and part value are not shown in Draft. See the GND symbol for an example. In addition, these types of parts are not shown in the Bill of Materials report.*

**SET**

Use **SET** to turn **Edit Library** options on and off. When you select **SET**, the menu shown at right appears.

| Set                |     |
|--------------------|-----|
| Auto Pan           | YES |
| Backup File        | YES |
| Error Bell         | YES |
| Left Button        | NO  |
| Macro Prompts      | YES |
| Power Pins Visible | NO  |
| Show Body Outline  | NO  |
| Visible Grid Dots  | NO  |

**SET Auto Pan**     **Auto Pan** controls movement past the screen boundary. While **Auto Pan** is turned on, when the pointer crosses a screen boundary, the screen pans in that direction.

When you select **Auto Pan**, you then choose between **Yes** and **No**. **Yes** turns on auto panning; **No** turns it off.

**SET Backup File**     When you set **Backup File** to **YES**, **Edit Library** creates a backup file when you write or update files using the **QUIT** command. The backup file contains the previous version of the library being edited.

**SET Left Button**     When **Left Button** is on, releasing the left mouse button executes the <Enter> key for command line commands only. Pressing the left mouse button continues to execute the command highlighted by the video bar in menus.

For example, suppose you select the **PLACE Wire** command and the "Begin Find Jump Zoom" command line displays at the top of the screen. To select **Begin** with the mouse when **SET Left Button** is disabled, you click the left button once to display the pop-up menu and once again to select **Begin**. When **SET Left Button** is turned on, you would instead press the left button and hold it down while you moved the highlight to **Begin**, then release the left button to select **Begin**, thus saving one button click.

When you select **Left Button**, you then choose between **Yes** and **No**. If you select **Yes**, releasing the left button on your mouse executes <Enter>. If you select **No**, releasing the left button on your mouse does not execute <Enter>.

- 
- SET Error Bell**      **Error Bell** turns the error bell (your computer's speaker) on and off. When you turn this option on, error messages and errors sound the speaker.
- When you select **Error Bell**, you then choose between **Yes** and **No**. **Yes** turns on the error bell; **No** turns it off.
- SET Macro Prompts**      When you select **Macro Prompts**, commands making up your macros display on the screen when macros run.
- SET Power Pins Visible**      When you select **Power Pins Visible**, the part's power pins appear on the screen. For example, if you set **Power Pins Visible** to **Yes** and display the part 74LS00 in the TTL library, pins 14 and 7 appear. For the 74LS00, 14 is Vcc and 7 is GND.
- Note power pins may overlap existing pin names or the part name. Typically, power pins do not display. Power pins do not display in the **Draft** schematic editor.
- SET Show Body Outline**      When you select **Show Body Outline**, the part's body outline appears as a dotted line. When editing a graphic part, you must edit within the body outline or unpredictable results occur. It's a good idea to display the part's body outline unless you have a compelling reason not to.
- SET Visible Grid Dots**      When you select **Visible Grid Dots**, grid dots display on the screen. The spacing of the grid dots depends on the current zoom scale.
- Scale 1*      The grid dots appear every grid unit.
- Scale Half*      The grid dots still appear every grid unit but, because **Scale Half** shows twice as much detail as **scale 1**, the grid dots appear twice as far apart.
- Scale Quarter*      The grid dots are placed every 0.1 grid unit apart.

## TAG

The TAG command identifies and remembers locations on **Edit Library's** screen. You can specify eight locations (A through H) using the pointer. Tagged locations can be destinations for the **JUMP** command. They are used when you want to quickly move the pointer to pre-defined locations. Tags do not appear on the part display, and they are not saved with the part.

Tag set

|       |
|-------|
| A tag |
| B tag |
| C tag |
| D tag |
| E tag |
| F tag |
| G tag |
| H tag |

To set a tag, place the pointer at a location you want to remember. Then select the TAG command. **Edit Library** displays the menu shown above.

When the TAG menu displays, select the tag to set from the menu. Once selected, **Edit Library** remembers the tag location. Once the tag is set, **Edit Library** returns to the main menu level.

**ZOOM**

**ZOOM** zooms in or out from the part display, changing the amount of detail you see on the screen. You can select three zoom levels: **1** (the default), **Half**, and **Quarter**. **Half** shows more detail than **1**, and **Quarter** shows more detail still.

When you select **ZOOM**, the menu shown at right appears.

The number or word in parentheses after **Center** shows the current zoom scale.

Zoom (present scale=1 )

Center (1 )

In (Half )

Out (1 )

Select

**ZOOM Center**

**Center** re-centers the displayed portion of the part around the pointer. This command is useful for centering a part on the screen for easy editing.

For example, if a part displays partially off the screen, you may center it by placing the pointer near the part's center and selecting **ZOOM Center**.

**ZOOM In**

**In** selects the next more detailed scale (the part appears larger).

**ZOOM Out**

**Out** selects the next less detailed scale (the part appears smaller).

**ZOOM Select**

**Select** chooses a current zoom level. The selected zoom level is shown in parentheses after **Center**.

Selecting **1** shows the part in normal scale. Then, **Out** has no effect because no less-detailed scale exists. **In** increases detail to the **Half** scale.

Selecting **Half** shows the part in two times the drawing resolution. Then, **Out** returns the scale to **1**, and **In** increases detail to the **Quarter** scale.

Selecting **Quarter** shows the part in four times the drawing resolution. Then, **Out** returns the scale to **Half**, and **In** has no effect because no more-detailed scale exists.







## *Decompile Library*

---

### Execution

**Decompile Library** takes a compiled library file and produces a library source file.

You can then edit the library source file, and use **Compile Library** to make a compiled library file. You can think of **Decompile Library** as the inverse of **Compile Library**.

### Running Decompile Library

Select **Decompile Library** from the **Schematic Design Tools** screen. Select **Execute** from the menu that displays.

**Decompile Library** creates the library source file from the library file usable by **Draft**.

When **Decompile Library** completes its task, the **Schematic Design Tools** screen appears.

## Local Configuration

With the Schematic Design Tools screen displayed, select **Decompile Library**. Select **Local Configuration** from the menu that displays.

Select **Configure DECOMP**. A configuration screen appears (figure 18-1).

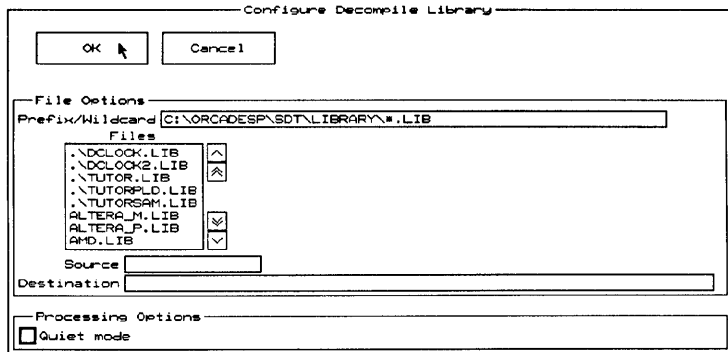

Figure 18-1. Decompile Library's local configuration screen.

**File Options** File Options names the library to decompile and the library source file to produce.

*Prefix/Wildcard* Enter a pathname and wildcard to define which files to display in the list box with scroll buttons. The asterisk character (\*) is used as a wildcard. The default is:

\ORCADESP\SDT\LIBRARY\\*.LIB

If you erase the entire field, the prefix specified on the **Configure Schematic Design Tools** screen is restored.

*Files* The files that match the search filter entered in the **Prefix/Wildcard** entry box and those that match the filter in the current design directory display in this box. Files in the current directory are shown with .\ before their names. Use the scroll buttons to scroll the list of libraries up and down.

Select the file to decompile by clicking on its name. Its path and filename display in the **Source** entry box.

**Source** The **Source** names an existing compiled library file. Specify **Source** by selecting a name from the **Files** list box, or enter a name by simply typing it in this entry box and pressing <Enter>.

△ **NOTE:** A question mark (?) in an entry box tells ESP to default to the **Startup Design** name. This simplifies changing between designs: all you need do is change the **Startup Design** on the **Configure ESP** screen, exit ESP, then restart ESP by entering `ORCAD`.

*For example, if you enter `? .LIB` in the **Source** entry box and the **Startup Design** is configured as "TUTOR," the next time you look at the local configuration, the **Source** entry box will be configured as "TUTOR.LIB." If you then change the **Startup Design** to "DESIGN2" and restart ESP, the **Source** entry box will be configured as "DESIGN2.LIB."*

**Destination** The **Destination** is the full path and filename of the library source file that **Decompile Library** produces. It is a text file that describes the parts in the specified library. If you give the name of an existing file, **Decompile Library** asks if you want to overwrite the existing file. You cannot append to an existing file.

The **Destination** can be a complete pathname.

**Processing Options** If desired, select the following option:

- Quiet mode  
Turns quiet mode on.





## *Creating a library source file with a text editor*

### **Library source file**

A library source file consists of the following:

- ❖ A prefix definition. You can only have one prefix definition per library, and it occurs at the beginning of the library.
- ❖ A series of part definitions. There are three types of part definitions: Block, Graphic, and IEEE.

### **Block part definitions**

Block part definitions represent parts that are either square or rectangular. These parts are typically memory chips, microprocessors, peripheral controllers, and many TTL and CMOS devices.

### **Graphic part definitions**

Graphic part definitions are used for small parts that have curved perimeters or whose function can be suggested by internal lines, circles, arcs, and fills. They include such parts as resistors, diodes, transistors, MOSFETS, relays and many others. A graphic part can be up to 1.2 inches by 1.2 inches in size.

If your part is larger than 1.2 inches by 1.2 inches, it must be an IEEE part (rather than a graphic part). However, if a graphic part's X axis is less than 1.2 inches, its Y axis can be larger than 1.2 inches, and vice versa. Think of it as a rubber band . . . if you stretch it in one direction, it thins out in the other.

**IEEE part definitions** IEEE part definitions represent parts that follow ANSI/IEEE standard. An IEEE part is similar to a graphic part, but it cannot contain arcs or fills. An IEEE part can also be larger than a graphic part. An IEEE part can be up to 12.7 inches by 12.7 inches.

△ **NOTE:** For more information, see ANSI/IEEE Std 91-1984: IEEE Standard Graphic Symbols for Logic Functions, ©1984, or Graphic Symbols for Electrical and Electronics Diagrams, ©1975; both published by The Institute of Electrical and Electronics Engineers, Inc.

---

## Prefix Definition

The prefix definition is specifically designed to handle the various TTL logic families. For example, the 74LS00, the 74S00, and the 74ALS00 have different prefixes (74LS, 74S, and 74ALS), but the same suffix (00). When you use a prefix definition, you reduce the memory required to store multiple families of parts with different prefixes, but the same suffix.

All source files *must* begin with a prefix definition. If you do not want a prefix definition in your custom library, you must still supply a null prefix.

### Use of the prefix definition

Draft uses the prefix definition when you obtain a part with the GET command. Instead of entering the entire name of the part, you can enter just the suffix. Draft displays a menu listing all the valid part names constructed by appending the suffix you provided with the prefixes in the prefix definition. For example, if TTL.LIB is one of your libraries and you enter the suffix 04, the menu lists the parts shown in figure 19-1.

Get? 04

|         |
|---------|
| 74LS04  |
| 74S04   |
| 74ASL04 |
| 74AS04  |
| 74HCT04 |
| 74HC04  |
| 74F04   |
| 7404    |

Figure 19-1. Valid part names displayed by entering the suffix "04".

**Constructing a prefix definition**

You can construct a prefix definition in a text editor as follows:

1. Enter the PREFIX keyword.
2. Begin the first prefix string by typing a single quote <'>. Type the prefix string. It consists of a string of text characters no more than seven characters long. Draft does not distinguish between upper- and lower-case. Close a prefix string with another single quote.
3. Type an equal sign <=>. To improve readability, you can enter any number of space or <Tab> characters before and after the equal sign.
4. Type the shorthand string. The shorthand string consists of no more than seven text characters. After you have entered the shorthand string, press <Enter> and type the next line. You can define a maximum of sixteen unique prefix strings.

The shorthand string is used to bypass the prefix menu and still enter an abbreviated part name. For example, you can obtain the part 74HC04, by supplying the GET command with the abbreviated name HC04. This is possible because HC is a shorthand string for 74HC.

5. Close the prefix definition by typing the keyword END alone on a line, followed by <Enter>.



**Example 1** This example below shows the prefix definition in the TTL.LIB library:

```
PREFIX
'74LS' = 'LS'
'74S' = 'S'
'74ALS' = 'ALS'
'74AS' = 'AS'
'74HCT' = 'HCT'
'74HC' = 'HC'
'74ACT' = 'ACT'
'74AC' = 'AC'
'74AHCT' = 'AHCT'
'74FCT' = 'FCT'
'74F' = 'F'
'74C' = 'C'
'74'
END
```

△ **NOTE:** To view the prefix definition of a library file, use *Decompile Library* to convert the file to a library source file. See Chapter 18: *Decompile Library* for details.

**Example 2** This is an example of a null prefix:

```
PREFIX
END
```

If you do not want prefixes in your library source file, you must use a null prefix at the beginning of the file.

## Part definition

The part definition defines the following characteristics of a part:

- ❖ Part name
- ❖ Part size (in grid unit lengths on the screen and in tenths of an inch on the printed worksheet, unless the template table changes during configuration)
- ❖ Number of parts per package
- ❖ Pin functions (input, output, open collector, etc.).

## Three types of part definitions

There are three types of part definitions: block symbol definitions, graphic definitions, and IEEE definitions. You don't have to group your block definitions, graphic definitions, and IEEE definitions together. For example, your source file may contain a block definition, followed by a graphic definition, followed by another block definition.

Block, graphic, and IEEE definitions follow much the same syntax. A graphic definition looks like a block or IEEE definition followed by bitmap and vector definitions. When **Compile Library** sees a bitmap, it uses the bitmap to represent the part, rather than defaulting to a square or rectangle.

## Components of a part definition

A part definition has the following fields:

- ❖ One or more part name strings. A name is a text string enclosed in single quotes. If you have more than one part name string, delimit them with a blank space or put them on separate lines. When obtaining a part, you can use any of the name strings.
- ❖ An optional sheet path designator. You can define a schematic file as a library part. This feature is useful for frequently used circuits.
- ❖ An optional reference designator. **Annotate Schematic** automatically updates reference designators.

- ❖ Symbol size. Each unit represents a grid unit length on the screen and 0.1 inch on the printed worksheet (unless the pin-to-pin spacing was changed in the template table during configuration). The X size is given first, followed by the Y size. Also included on this line is one of the following:
  - The number of parts per package
  - The keyword GRIDARRAY if the part is a pin grid array
  - The keyword IEEE if the part is an IEEE part
- ❖ Pin definition. Each pin is defined on a separate line. A pin definition consists of the following fields:
  - Pin position.
  - Pin number or GRIDARRAY pin name enclosed in single quotes.
  - Optional keywords:
    - DOT      Puts an inversion bubble at the pin position.
    - CLK      Puts a clock symbol at the pin position.
    - SHORT    Puts leads one grid unit long at the pin position (instead of standard three-grid-unit leads).

If DOT and CLK are used together, DOT must come first. SHORT cannot be used with DOT or CLK.

  - Pin function (*input, output, input/output, open collector, open emitter, power, passive, hi-z*).
  - Pin name string enclosed in single quotes.

An example of a pin definition is shown in figure 19-2.

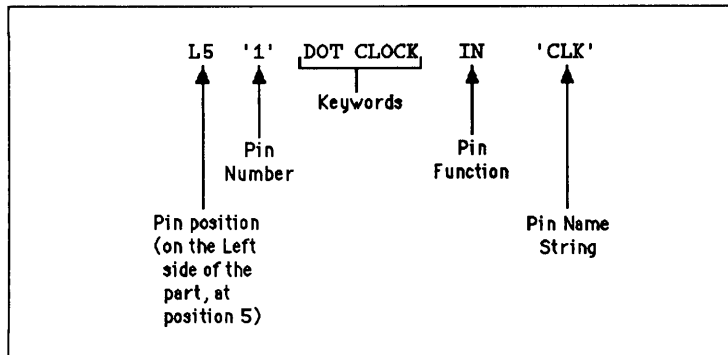

Figure 19-2. Pin definition line.

For specific details about defining a pin, see *Chapter 20: Symbol Description Language*.

- ❖ An optional bitmap definition. Use this if the symbol you want is not a square or rectangle.
- ❖ An optional vector definition. This describes a graphic part in vector format. **Edit Library** and **Plot Schematic** use vector definitions for screen display and plotting.
- ❖ An optional converted form bitmap definition. This only has meaning if you've defined a bitmap. The most common use for converted bitmaps is to specify the DeMorgan equivalent symbol of the defined part.
- ❖ An optional converted form vector definition. This describes the converted form of a graphic part in vector format.

## Defining a block symbol

Figure 19-3 is an example of a block symbol definition. The example does not represent a real part, although it is similar to a JK flip-flop. Figure 19-4 shows the symbol produced by this block definition.

Part name string -----  
 Reference designator -----  
 Grid unit size (6 x 10) and -----  
 number of parts per package (2)

Pin definitions -----  
 Column 1 gives the pin location (i.e. L1=left side, position 1; L5=left side, position 5; L0=the top of the left side, etc). Column 2 gives the pin's number in the first part in the package (i.e. L1=3, L5=1, etc.). Column 3 gives the pin's number in the second part in the package (i.e. L1=11, L5=13, etc.) The fourth column gives an optional keyword (DOT, CLOCK, or SHORT), and the pin's function. The last column gives the pin name string.

|           |    |    |            |       |
|-----------|----|----|------------|-------|
| '74EXAMP' |    |    |            |       |
| REFERENCE |    |    | 'LATCH'    |       |
| 6         | 10 | 2  |            |       |
| L1        | 3  | 11 | SHORT IN   | 'J'   |
| L5        | 1  | 13 | DOT CLK IN | 'CLK' |
| L9        | 2  | 12 | SHORT IN   | 'K'   |
| B3        | 15 | 14 | DOT IN     | 'CL'  |
| T3        | 4  | 10 | DOT IN     | 'P'   |
| R1        | 6  | 7  | OUT        | 'Q'   |
| R9        | 5  | 9  | OUT        | 'Q\'' |
| T0        | 16 | 16 | PWR        | 'VCC' |
| B0        | 8  | 8  | PWR        | 'GND' |

Figure 19-3. Block symbol definition for 74EXAMP.

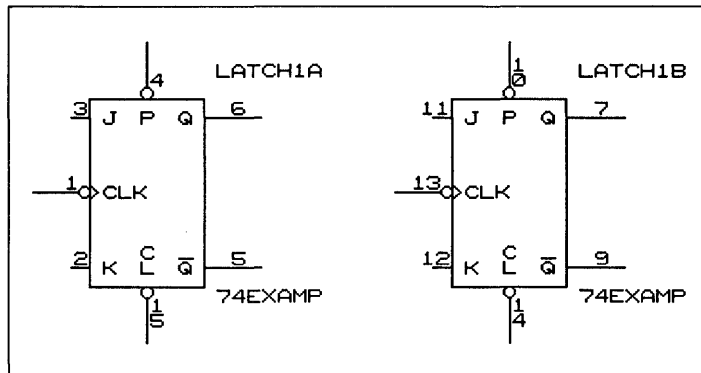

Figure 19-4. The block symbol for 74EXAMP.

Note the components making up the part definition. The first line is the part name string, 74EXAMP. The next line is the reference designator, LATCH. The third line represents the grid unit size and the number of parts per package. The remaining lines, starting with line four, are the pin definitions.

**Part name string**

The example on the previous page has only one part name string, '74EXAMP'. If you want to refer to the same part with different names you can list a number of part names. For example, to use the same part definition for the 8031, 80C31, 8051, 80C51, and 8751 components, put all five part name strings at the beginning of the part definition, as shown in figure 19-5.

```
'8031'
'80C31'
'8051'
'80C51'
'8751'
{X Size =} 13 {Y Size =} 25 {Parts per Package =} 1
L1      31      IN  'E\A\VP'
L3      19      IN  'X1'
L6      18      IN  'X2'
.
.
.
```

Figure 19-5. Block symbol definition with multiple part names.

Notice that comments are enclosed in curly braces, as in figure 19-5. The X and Y coordinates are preceded by comments, as is the number of parts per package.

**Sheetpath keyword**

The example in figure 19-3 does not have a SHEETPATH keyword. If you need to have a part reference a schematic sheet, place the following line after the part name strings:

```
SHEETPATH 'schematic_filename'
```

where *schematic\_filename* is the name of a schematic you have already drawn. Then, whenever you place a sheet-path part on your design, you actually place a copy of this schematic. Use sheetpath parts to represent frequently used circuits.

Normally, the filename does not include a pathname. If it doesn't, Draft looks for the schematic in the current library directory. If the sheetpath references a sub-circuit that is common to many designs, you can include a full pathname along with the filename.

**Reference keyword**

If a reference designator is used, it comes after the part name string (and sheetpath designator, if there is one).

In the example in figure 19-3, the reference designator appears as "LATCH." When you run **Annotate Schematic** on a design containing the part, the question mark is replaced with a number. For example, if the reference designator for a resistor is R? and there are sixteen resistors in your design, **Annotate Schematic** changes the designators to R1, R2, . . . R16. You can also manually replace the question mark when you place the part in a worksheet with **Draft**.

This example has more than one part per package, so the reference designator appears with an A after the question mark. **Annotate Schematic** then sequences the letters. **Annotate Schematic** converts the A of the second part into a B. For example, after running **Annotate Schematic**, the first two occurrences of the 74EXAMP appear as LATCH1A and LATCH1B, the next two as LATCH2A and LATCH2B, etc.

If you omit the REFERENCE line, the default designator U?A appears on the schematic.

What appears for the reference designator when you get a part is determined as follows:

1. If the device has zero parts per package and you do not specify a REFERENCE keyword, no reference or part name appear.
2. If the device has zero parts per package and you specify a REFERENCE keyword, the reference appears. It consists of the string you specified followed by a question mark. The part name also appears.



*NOTE: If, for some reason, you want a part without pin numbers, use a device with zero parts per package.*

3. If the device has one or more parts per package, and you do not specify a REFERENCE keyword, a default reference designator (U?A) appears. The part name also appears.

4. If the device has one or more parts per package, and you specify a REFERENCE keyword, the reference appears. It consists of the string you specified followed by ?A (assigned and displayed by Draft). The part name also appears.

Table 19-1 shows the relationship between the number of parts per package and the reference designator appearing on the part. You must specify a part name; the name is what Draft uses to get a device from the library. The REFERENCE keyword is optional, however. If the REFERENCE keyword is not specified, it defaults to U.

| Source File . . .                | Number of Parts Per Package                        |  |
|----------------------------------|--|--|
|                                  | 0  | 1 or more  |
| Does not use "REFERENCE" keyword | Nothing is displayed                               | "U" is default reference designator                |
| Uses "REFERENCE" keyword         | Uses reference keyword you enter in source library | Uses reference keyword you enter in source library |

Table 19-1. Controlling display of reference designators.

### Grid unit size and parts/package

The next line in figure 19-3 contains the three numbers 6 10 2. The first two numbers (6 and 10) represent the size. The size of the part is 6X by 10Y, where each unit represents one screen unit or 0.1 inch on the printed worksheet (if the pin-to-pin spacing in the **Template Table** section of the **Configure Schematic Design Tools** screen is 0.1 inch). The third number (2) indicates there are two parts per package. If the part is a pin-grid array, supply the keyword GRIDARRAY in place of the number of parts per package. If the part is an IEEE part, supply the keyword IEEE in place of the number of parts per package.



**Pin definitions**

The remaining lines in the example in figure 19-3 consist of the pin definitions. Consider the second pin position as an example.

The first field L5 locates the pin on the left side of the part in the fifth position counting down from the top. The previous line in figure 19-3 defined the Y dimension as 10. This means that there are 11 possible vertical positions, 0 through 10. The first possible position on the left side of the part is L0 and the last is L10. Likewise, the right side of the part contains positions R0 through R10. The specified pin position (L5) is on the left side of the part, 5 grid units from the top of the part.

The next two fields for pin position L5 identify the pin numbers. L5 is numbered 1 on the first part of the package and 13 on the second part of the package.

The fourth field for pin position L5 specifies DOT to obtain the inversion bubble and CLK to get the clock symbol. In this case, DOT and CLK are modifiers of the pin function, IN.

Finally, the last field for pin position L5 gives the pin a name of 'CLK'.

Refer back to figure 19-4 and locate pin L5 on the two parts in the package. They are both labeled "CLK".

As further examples, consider R9 and B3. R9 puts a pin on the right side in the ninth position, and B3 puts a pin on the bottom in the third position counting from the left. The two power supply connections are at the top and bottom in the zero position.

Note the vertices of a part have two possible representations. For example, L0 and T0 specify the same pin location (the upper left-hand corner).

▲ **CAUTION:** *If you place a power pin at T0 and another power pin at L0, those pins are electrically connected.*

Figure 19-6 shows a grid representing the possible pin positions for the 74EXAMP library part.

Note the SHORT keyword in the L1 pin position in figure 19-3. Pins with the SHORT keyword have one-grid-unit leads rather than the default three grid units. The SHORT keyword, however, cannot be used with DOT or CLK keywords.

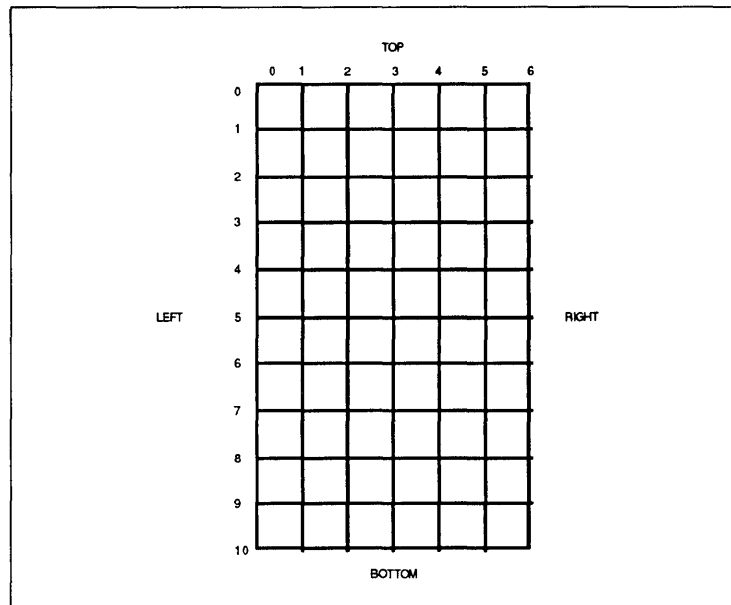

Figure 19-6. The grid of a 6X by 10Y block symbol.

**Pin type** One possible pin type is PWR for power. Power pins do not appear on the screen. The connectivity database, however, does categorize all power pins connected to library parts.

If you wish to make parts with visible power pins, use the IN or PAS pin type instead of PWR. Remember to position the pin name (if it is a block part) so that it does not overlap other pin names.

### Selectively displaying pins

If the device has more than one part per package, you can selectively display the pins. For example, assume you want to display the pins VCC and GND, but only on the second part of the device, not on the first. You can do this by coding the last two lines of the block symbol as follows:

```
T0 0      16      PAS 'VCC'  
B0 0      8       PAS 'GND'
```

When you place this symbol on the screen, the passive pins do not display because the first column of pin locations contains a 0. When you place another symbol on the screen, it looks identical to the first. Both are called FF?A, and neither shows the power pins.

However, if you use Draft's EDIT command to change the reference designators to FF1A and FF1B, the power pins appear only on the second part of the device, FF1B. You can also use Annotate Schematic to change the reference designators.

This technique also works for other types of pins. By specifying a pin number of 0, you can cause a pin not to appear for the part of a package. But if your device has one part per package, specifying a pin number of 0 does not prevent the pin from appearing. The pin appears with a pin number of 0.

△ *NOTE: If you want a part without pin numbers, use a device with zero parts per package.*

If your device has zero parts per package, you do not specify pin numbers. Figures 19-7 and 19-8 illustrate how the number of parts per package, the pin number, and the Annotate Schematic tool affect the screen symbol.

The device 74ONE is identical to 74EXAMP, except it has only one part per package. Note the Annotate Schematic tool affects both the pinout and reference designator for 74EXAMP, but only the reference designator for 74ONE.

Also note the definition of 74EXAMP was modified so the power pins only appear in the second part of the package. In both 74ONE and 74EXAMP the locations of the power pins were moved from T0 and B0 to R3 and R7, so they would not overlap existing pins.

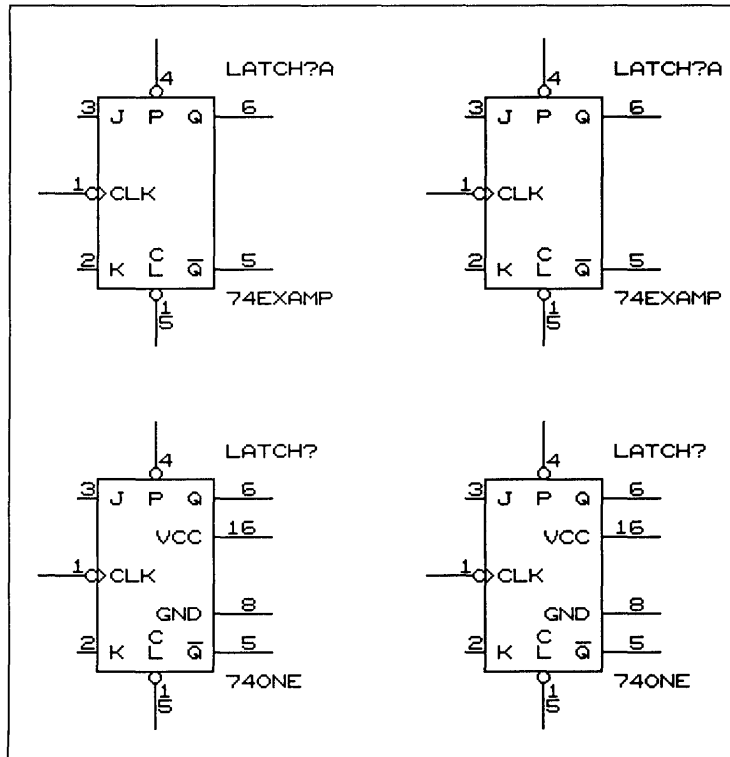

Figure 19-7. Before annotation.

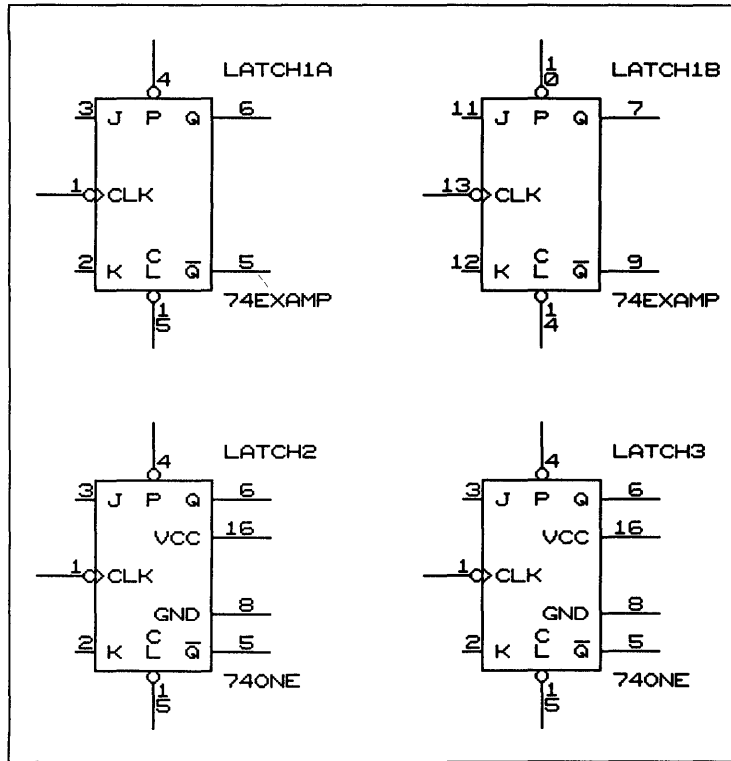

Figure 19-8. After annotation.

**Pin-grid array**

If the part is a pin-grid array, you supply the grid array pin name instead of the pin number. A grid array pin name consists of any string of up to 15 alphanumeric characters enclosed in single quotes.

Figure 19-9 is an example of a pin-grid array part definition. The example is the 68020 from the Motorola library, MOTO.LIB. The definition is quite long so only a few lines are shown. Notice the keyword GRIDARRAY on the second line, and the pin names in the second field on each pin definition line.

Figure 19-10 shows the resulting screen figure.

```
'68020'
{X Size =} 16 {Y Size =} 53 {Part is a} GRIDARRAY
L1 'C2' CLK IN 'CLK'
L3 'J12' DOT IN 'IPL0'
L4 'J13' DOT IN 'IPL1'
L5 'H12' DOT IN 'IPL2'
L7 'H2' DOT IN 'AVEC'
L8 'A1' DOT IN 'BGACK'
L9 'B3' DOT IN 'BR'
L10 'J2' DOT IN 'BERR'
.
.
.
```

Figure 19-9. Pin-grid array part definition.

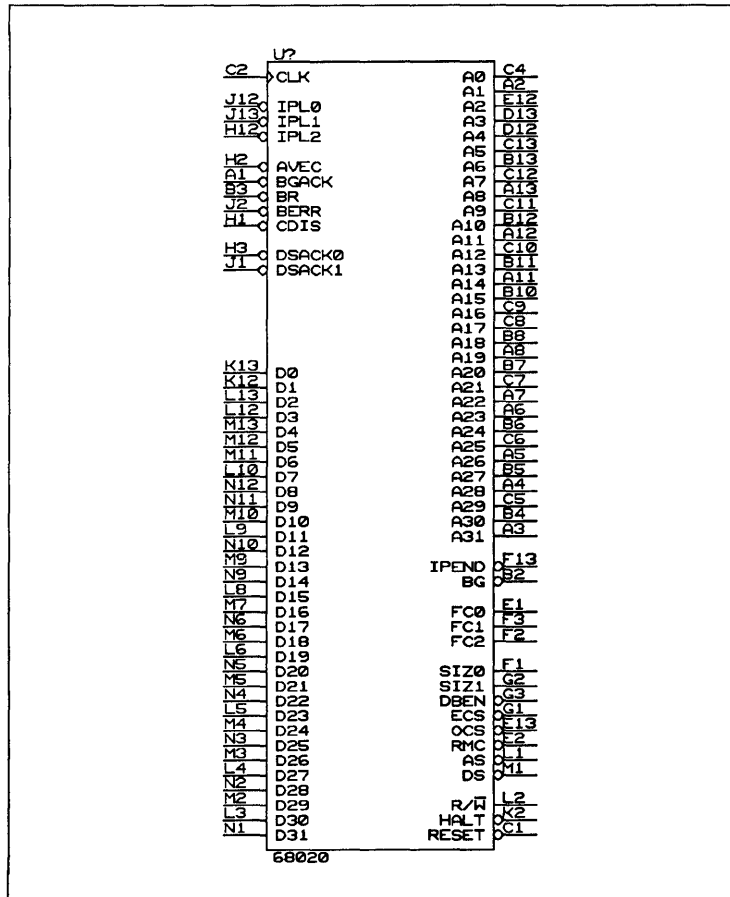

Figure 19-10. The block symbol for the 68020 defined in figure 19-9.

*Pin string*     The pin string is delimited by single quotes. If you want a single quote as part of the pin string, you must use two single quotes. For example, 'CLK"s' defines the string CLK"s. Also, a backslash after the pin string name puts a bar over the name. 'Q\' results in Q with a bar over it (  $\bar{Q}$  ). If you have a multi-letter pin name, you must put a \ after each letter. For example, if you wanted the pin name IPL0 to have a bar above all four letters, the corresponding pin string entry in the part definition would be '\P\L\0\'.

## Defining a graphic symbol

A graphic symbol definition is composed of two parts: a bitmap definition and a vector definition. Both definitions are optional. However, **Draft** requires a bitmap, while **Plot Schematic** requires vectors. A bitmap definition specifies which screen pixels should be “turned on” when the part displays in **Draft**. A vector definition specifies the shape of the part in vector format. The vector definition is used by the **Edit Library** and the **Plot Schematic** tools.

### Defining a bitmap

Creating a bitmap is an easy way to represent non-rectangular parts such as resistors, diodes, transistors, MOSFETs, relays, and many others. **Draft** draws complex parts by selectively turning on pixel bits representing the library part. Activating the correct pixel bit is controlled by a bitmap in the library source file you created.

To define a part with a bitmap, you define the part just as if it were a block symbol, but you include a bitmap after the last pin definition. You can either draw the bitmap with periods (.) and pound signs (#) (see figure 19-11 for an example), or you can reference a previously drawn bitmap. “Previously drawn” means the bitmap was defined earlier in the library source file.

Refer to a previously drawn bitmap if two parts have different pinouts, but the same symbol. For example, the 7439 and the 7400 have the same symbol, but different pinouts. Assume you’ve defined the 7400 and you’re now defining the 7439. Instead of drawing another bitmap, you can use the 7400’s for the 7439 by including the line:

```
BITMAP '7400'
```

If you don’t reference a previously drawn-out bitmap, you must specify the part’s own bitmap. The bitmap begins after the last pin definition. A pound sign (#) indicates the pixel bit is turned on, and a period (.) indicates the pixel bit is turned off.



Each . or # in the bitmap represents a screen pixel spacing of 0.01 inch in the X direction. Each line of the bitmap represents 0.01 inch in the Y direction. Remember, the X and Y sizes in the part definition are given in units of 0.1 inch. For example, if you specify X and Y to be 3 and 2, your bitmap actually is 31 characters in the X direction and 21 lines in the Y direction. The extra 1 results because the bitmap starts counting at zero. Figure 19-11 shows the bitmap for a graphic.

### Defining a vector

Following the bitmap definition, you can specify a vector definition of the part. A vector definition is a set of circle, arc, line, text, and fill specifications that define the shape of the part in vector form.

Each line in the vector definition specifies one graphical piece of the part. For example, the following lines define an AND gate:

```
VECTOR
LINE +4.0 +0.0 +0.0 +0.0 {Top}
LINE +0.0 +0.0 +0.0 +4.0 {Left}
LINE +0.0 +4.0 +4.0 +4.0 {Bottom}
ARC +4.0 +2.0 +0.0 -2.0 +2.0 +0.0 +2.0
ARC +4.0 +2.0 +2.0 +0.0 +0.0 +2.0 +2.0
END
```

The first line identifies the beginning of the vector definition. The next three lines specify the beginning and ending points of the top, left, and bottom lines in the AND gate. The next two lines define the two arcs making up the half circle on the right side of the part. Finally, the last line denotes the end of the vector definition. For details on defining vectors, see *Chapter 20: Symbol Description language*.

**Graphic symbol considerations**

There are a few points you should keep in mind when creating a graphic symbol, as opposed to a block symbol.

1. You have to pay close attention to pin placement. For example, if you wanted to build the part shown at right, you would need to be very careful placing pin 3.

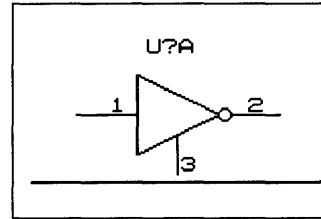

The reason for this is that the pin will be placed on the part boundary. This means that your custom part will have blank space between itself and the body of the part. You will probably want a graphic line between the part boundary side of the pin and the part body.

You will probably prefer to build this custom part in **Edit Library**.

△ **NOTE:** To make your custom part look nice, place a short pin on the part boundary as you usually would. Then, draw a graphic line from the pin to the line you need to connect it to.

2. Although you can put a pin name in the pin definition, the pin name does not appear on the screen. The pin name is, however, recognized connectivity database.
3. A graphic symbol can include a converted form of the symbol. Graphic devices always have a normal form; optionally, they can have a converted form. Usually (but not always), the converted form is the DeMorgan equivalent symbol of the normal form.

When you use the **GET** command in **Draft**, and extract a graphic part from a library, it appears in normal form. From the menu that displays, you can also choose its converted form instead. You define what the converted form is when you create the library source file.

Block and IEEE symbols cannot have converted forms.

4. The maximum number of bits allowed in a bitmap is 16,384. However, bitmaps are allocated in blocks of eight. So consider a bitmap consisting of 21 rows of 31 bits. Rather than  $21 * 31 = 651$  bits, the space actually taken up by such a bitmap is  $21 * 32 = 672$  bits.
5. The **Edit Library** and **Plot Schematic** tools use vector definitions. So, although vectors are optional, you won't be able to edit the part with **Edit Library** or plot it with **Plot Schematic** if you don't use vectors.

### Converted form graphic symbol

After defining a graphic symbol, you have the option of defining a converted form graphic symbol. As stated previously, the typical use of a converted form graphic symbol is to supply a DeMorgan equivalent symbol, but more generally a converted form specifies another graphic symbol to display on the screen whenever you choose the **Convert** option of the **GET** command. You can return to the original graphic symbol by selecting **Normal**.

Begin the specification of a converted form graphic symbol with the keyword **CONVERT**. The converted form graphic symbol consists of pin definitions followed by a bitmap and a vector definition. If the converted form is already defined, you can reference it by including the name of the part with the converted form in single quotes.

Here's a more detailed example showing how to use the converted form graphic symbols. The definition of the 7400 is shown first. Then, the converted form graphic symbol—the DeMorgan equivalent of the 7400—is shown. Figure 19-11 and figure 19-12 show both the normal and converted symbols resulting from this part definition.

The 7400 has five pins, two of which are power pins not appearing in the symbol. The screen size is 6 X-units and 4 Y-units. It has four parts per package.

The converted form graphic symbol uses the same XY size and parts per package as the normal graphic symbol. You must, however, redefine the pin types. Note the **DOT** keyword missing from the redefinition of the pin at R2.

Also note that the converted form graphic symbol has the same number of parts per package as the normal graphic symbol. The number of parts per package determines how many columns of pin numbers appear in the definition. The converted definition must have the same number of columns as the normal definition.

Note that the part definition in figure 19-11 contains both the bitmap and vector definition of the part.

```
'7400'
{X Size =} 6      {Y Size =} 4      {Parts per Package =} 4
L1  1  4  9  12      IN  'I0'
L3  2  5  10 13      IN  'I1'
R2  3  6  8  11 DOT  OUT  'O'
T0  14 14 14 14      PWR  'VCC'
B0  7  7  7  7      PWR  'GND'
{000000000011111111112222222222333333333344444444445555555556}
{.....}
{0123456789012345678901234567890123456789012345678901234567890}
{.....}
{ 0.0}#####
{ 0.1}#.....#####
{ 0.2}#.....###
{ 0.3}#.....##
{ 0.4}#.....###
{ 0.5}#.....##
{ 0.6}#.....##
{ 0.7}#.....##
{ 0.8}#.....#
{ 0.9}#.....##
{ 1.0}#.....##
{ 1.1}#.....#
{ 1.2}#.....##
{ 1.3}#.....#
{ 1.4}#.....#
{ 1.5}#.....#
{ 1.6}#.....##
{ 1.7}#.....#
{ 1.8}#.....#
{ 1.9}#.....#
{ 2.0}#.....#
{ 2.1}#.....#
{ 2.2}#.....#
{ 2.3}#.....#
{ 2.4}#.....##
{ 2.5}#.....#
{ 2.6}#.....#
{ 2.7}#.....#
{ 2.8}#.....##
{ 2.9}#.....##
{ 3.0}#.....##
{ 3.1}#.....##
{ 3.2}#.....#
{ 3.3}#.....##
{ 3.4}#.....##
{ 3.5}#.....##
{ 3.6}#.....###
{ 3.7}#.....##
{ 3.8}#.....###
{ 3.9}#.....#####
{ 4.0}#####
VECTOR
LINE  +4.0 +0.0 +0.0 +0.0  {Top}
LINE  +0.0 +0.0 +0.0 +4.0  {Left}
LINE  +0.0 +4.0 +4.0 +4.0  {Bottom}
ARC   +4.0 +2.0 +0.0 -2.0 +2.0 +0.0 +2.0
ARC   +4.0 +2.0 +2.0 +0.0 +0.0 +2.0 +2.0
END
```

Figure 19-11. The 7400 symbol.

```

CONVERT
L1      1   4   9  12      IN  'I0'
L3      2   5  10  13      IN  'I1'
R2      3   6   8  11      OUT 'O'
T0     14  14  14  14      PWR 'VCC'
B0      7   7   7   7      PWR 'GND'
      {0000000000111111111222222222233333333334444444445555555556}
      {.....}
      {0123456789012345678901234567890123456789012345678901234567890}
{ 0.0}#####
{ 0.1}##.....#####
{ 0.2}##.....#####
{ 0.3}##.....#####
{ 0.4}##.....#####
{ 0.5}##.....#####
{ 0.6}##.....#####
{ 0.7}##.....#####
{ 0.8}##.....#####
{ 0.9}##.....#####
{ 1.0}##.....#####
{ 1.1}##.....#####
{ 1.2}##.....#####
{ 1.3}##.....#####
{ 1.4}##.....#####
{ 1.5}##.....#####
{ 1.6}##.....#####
{ 1.7}##.....#####
{ 1.8}##.....#####
{ 1.9}##.....#####
{ 2.0}##.....#####
{ 2.1}##.....#####
{ 2.2}##.....#####
{ 2.3}##.....#####
{ 2.4}##.....#####
{ 2.5}##.....#####
{ 2.6}##.....#####
{ 2.7}##.....#####
{ 2.8}##.....#####
{ 2.9}##.....#####
{ 3.0}##.....#####
{ 3.1}##.....#####
{ 3.2}##.....#####
{ 3.3}#####
{ 3.4}##.....#####
{ 3.5}##.....#####
{ 3.6}##.....#####
{ 3.7}##.....#####
{ 3.8}##.....#####
{ 3.9}##.....#####
{ 4.0}#####

VECTOR
LINE   +2.5 +0.0 +0.0 +0.0
LINE   +2.5 +4.0 +0.0 +4.0
ARC     +2.5 +4.0 +3.5 -2.0 +0.0 -4.0 +4.0
ARC     -2.0 +2.0 +2.0 -2.0 +2.8 +0.0 +2.8
ARC     -2.0 +2.0 +2.8 +0.0 +2.0 +2.0 +2.8
ARC     +2.5 +0.0 +3.5 +2.0 +0.0 +4.0 +4.0
CIRCLE  +0.3 +3.0 +0.3
CIRCLE  +0.3 +1.0 +0.3
END

```

Figure 19-12. The converted form of the 7400 symbol.

## Defining an IEEE symbol

An IEEE symbol is composed of the following parts: a name string, a size and type definition, a pin definition, and a vector definition.

### Part name string

The part name string is defined the same as for block and graphic symbols. To refer to the same part with different names, you can list multiple part names as shown below.

```
'74ALS114'
'74ALS114A'
'74AS114'
'74F114'
'74HC114'
'74LS114'
'74S114'
{X Size =} 8      {Y Size =} 12      {Part is a} IEEE
T6  14      PWR  'VCC'
B6  7       PWR  'GND'
L1  1       IN   'C\L\R\'
L2  13      CLK IN 'CLK'
L5  4       IN   '1P\R\E\'
L6  3       IN   '1J'
L7  2       IN   '1K'
L9  10      IN   '2P\R\E\'
L10 11      IN   '2J'
L11 12      IN   '2K'
R6  5       OUT  '1Q'
R7  6       OUT  '1Q\'
R10 9       OUT  '2Q'
R11 8       OUT  '2Q\'
VECTOR
LINE  +0.0 +0.0 +0.0 +3.0
LINE  +0.0 +3.0 +1.0 +3.0
LINE  +1.0 +3.0 +1.0 +4.0
LINE  +0.0 +4.0 +0.0 +12.0
LINE  +0.0 +12.0 +8.0 +12.0
LINE  +8.0 +12.0 +8.0 +4.0
LINE  +8.0 +4.0 +0.0 +4.0
LINE  +7.0 +4.0 +7.0 +3.0
LINE  +7.0 +3.0 +8.0 +3.0
LINE  +8.0 +3.0 +8.0 +0.0
LINE  +8.0 +0.0 +0.0 +0.0
LINE  +0.0 +8.0 +8.0 +8.0
TEXT  -1.2 +1.0 1  ACTIVE_LOW_L
TEXT  -1.2 +2.0 1  ACTIVE_LOW_L
TEXT  -1.2 +5.0 1  ACTIVE_LOW_L
TEXT  -1.2 +9.0 1  ACTIVE_LOW_L
TEXT  +8.0 +7.0 1  ACTIVE_LOW_L
TEXT  +8.0 +11.0 1 ACTIVE_LOW_L
END
```

Figure 19-13. IEEE symbol definition for 74114 parts.

**Size and type definitions**

The line following '74S114' in figure 19-13 contains the numbers 8 and 12, followed by the letters IEEE. The comments inside the curly braces (see figure 19-13) show the X Size, Y Size, and the keyword IEEE.

The keyword IEEE means the part is an IEEE-type symbol and, therefore, has one part per package and does not have a convert.

**Pin definitions**

Following the size and type definitions is the pin definitions section.

For example, look at the fourth position. The first field, L2, locates the pin on the left side of the part in the second position from the top. The next field defines the pin number: pin 13. The third field describes the function of the pin and defines how it will be drawn. "CLK IN" defines an input pin drawn with the clock symbol (>).

Finally, the last field for pin position L2 names the pin "CLK."

**Vector definitions**

Vector definitions are similar to those of a graphic symbol with the following exceptions:

- ❖ The allowed vector types include only: CIRCLE, LINE, and TEXT. ARC and FILL are not allowed.
- ❖ You have more freedom when drawing the vector components. In particular, some components must be placed outside the part body. For example, an input ACTIVE\_LOW must be placed to the left of the part body, as shown by pins 1, 4, 10, and 13 in figure 19-14. Inputs placed to the left of the part body have a negative X offset in the vector section of the IEEE symbol definition. See figure 19-13.

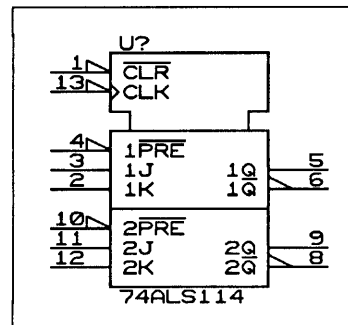

Figure 19-14. The 74ALS114 IEEE part.



*Defining a vector*

A vector definition for an IEEE part is a set of circle, line, and text specifications that define the shape of the part in vector form. Each line in the vector definition specifies one piece of the part's body.

The first line of the vector section identifies the beginning of the vector definition with the keyword "VECTOR." In figure 19-3, the next twelve lines—beginning with the keyword "LINE,"—specify the starting and ending points of all the lines in the body of the part.

The nine lines beginning with the keyword "TEXT," specify the locations of the text on the part. Finally, the last line denotes the end of the vector definition. For details on vectors, see *Chapter 20: Symbol Description Language*.



**NOTE:** *Plot Schematic* draws IEEE parts using Vector commands in the order they are defined in the vector section of the IEEE symbol definition. You can minimize plotter pen travel and Up-Down commands by careful ordering. This can save quite a bit of plotting time.

*IEEE standards*

IEEE symbols are designed to create parts that meet the IEEE drawing standards in *ANSI/IEEE Std 91-1984*. Some of the requirements of this standard are not entirely intuitive. It is an excellent idea to study the standards before beginning any major effort to draw a new set of IEEE parts.

*Size*

IEEE symbol dimensions can be up to 12.7 × 12.7 inches. The symbols can contain many internal vector objects. All but the very largest ASIC devices can be drawn as IEEE parts.

In some cases, though, it may be more practical to use SHEET symbols on actual designs. In particular, if an ASIC device has a large number of signals which can be represented as buses, it may be easier and clearer to show the device with a small number of bus connections and a reasonable number of control signals.

*Pin placement* In general, the IEEE standard wants pins placed only on the left and right side of parts: inputs on the left, and outputs on the right. **Schematic Design Tools** does allow you to place pins on the top and bottom, however, to support ASIC devices with more than 255 pins. See *Size* above for information on the use of SHEET symbols for handling ASIC devices.

*Building the IEEE body outline* IEEE symbols usually have a rectangular outline. They often consist of a control section on top of a main signal section. There are usually indentations in the outline near the bottom of the control section. Normally the indentations are 0.1 inch high. Figure 19-14 shows an example.

Defining this visual aspect cannot be done automatically. You have to specify the outline with LINE commands.

*IEEE Vector Objects* Use TEXT commands to place IEEE objects such as those shown at right. The objects are drawn to be eight units high when used with a size argument of one. This is the same height as text of size one. It also fits nicely between pins which are normally spaced ten units apart. The horizontal component was chosen to match the suggestions contained in the IEEE standard. This height and width makes the

|               |
|---------------|
| Negation      |
| Active_Low    |
| Arrow         |
| BiDirectional |
| Dynamic       |
| Non_Logic     |
| Analog        |
| 3 State       |
| Amplified     |
| Passive       |
| Open Circuit  |
| Postponed     |
| Hysteresis    |
| Generator     |
| Shift         |

objects easy to read in **Draft** at Zoom scale 1 and for plots or hardcopy that is done at 100 dots per inch.

*Placing ACTIVE\_LOWs*

The IEEE standard suggests an ACTIVE\_LOW be drawn so that it is 1.5 times as wide as it is high. Since OrCAD's IEEE objects are 8 units high by default, this means the ideal width of an ACTIVE\_LOW is 12 units. In a TEXT command, "1.2" represents 12 units. ACTIVE\_LOW inputs are usually placed with -1.2 X offset in order to get the point of the triangle on the outline.

The IEEE standard implies that ACTIVE\_LOWs should only be used external to a part body. Signals internal to the body are intended to be logical, not physical. Hence, Negation or CIRCLES should be used where a logical inversion operation is needed inside a part.

△ *NOTE: When a part is IEEE type, you have considerable leeway in deciding where the vector objects should be placed. As a result of various aspects of the IEEE standard, they can be either inside or outside the part's body outline. Any time you draw a library part with objects outside the part's body, however, you increase the chances of creating a messy and possibly confusing schematic. For this reason, add Vector objects outside the part's body only if there's no other way to define the part properly.*



# Symbol Description Language

This chapter describes how to define a part in a custom library. It presents OrCAD's Symbol Description Language (SDL) in the form of syntax diagrams. A syntax diagram consists of identifiers (enclosed in ovals) and tokens (enclosed in rectangles).

## Syntax diagram

Figure 20-1 is an example of a syntax diagram. It represents the complete syntax for a library source file.

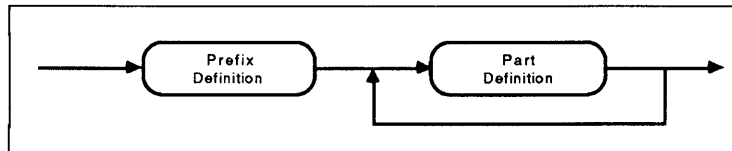

Figure 20-1. Syntax diagram for a library source file.

To read a syntax diagram, follow these rules:

1. Read the diagram from left to right.
2. The direction of the arrows on a path represent correct syntax forms.
3. Junctions represent a connection point where you have the choice of selecting another path. For example, the syntax diagram for the library source file shown in figure 20-1 has a junction after a Part Definition. You can choose to complete the diagram or to make another Part Definition.

4. You cannot travel a path going against the arrows. For example, in figure 20-1, you cannot return to the prefix definition after you make a part definition.
5. Text enclosed in ovals represents an identifier. Text enclosed in squares represents a token. Identifiers and tokens are described below.

**Identifiers** Identifiers serve as placeholders for a more detailed level of syntax structure. They do not represent command syntax or tokens. Rather, they provide the ability to give an overview of the syntax. When you create the part, you must work down through all the nested identifiers. For example the syntax diagram for a library source file shown in figure 20-1 has two identifiers (Prefix Definition and Part Definition) and no tokens.

**Tokens** Tokens are the building blocks of a library source file. Just as a sentence is made up of words, a library source file is made up of tokens. A token belongs to one of the following categories:

- ❖ **Numeric constants.** A numeric constant consists of one or more whole-number digits.

Examples:

|    |     |
|----|-----|
| 15 | 127 |
| 2  | 98  |

- ❖ **Character strings.** A character string consists of one or more alphanumeric characters.

Examples:

|         |       |
|---------|-------|
| 74ALS04 | L5    |
| CLOCK   | ZENER |

- ❖ **Keywords.** A keyword is one of the following:
  - BITMAP** Takes an argument (a text string representing a part name) and represents the bitmap of the identified part.
  - CLK** Represents the clock symbol in a pin definition.
  - CONVERT** Introduces a converted graphic symbol definition. With an argument, it refers to the converted bitmap and vector definitions of a graphic symbol.
  - DOT** Represents the inversion bubble in a pin definition.
  - END** Specifies the close of a prefix or vector definition.
  - GRIDARRAY** Specifies the device is a pin-grid array. Used in place of the number of parts per package.
  - HIZ** Identifies the pin as a high impedance (state) output.
  - IEEE** Specifies that the object is an IEEE object, and will conform to IEEE drawing standards.
  - IN** Identifies the pin as an input.
  - I/O** Identifies the pin as input/output.
  - OC** Identifies the pin as open collector.
  - OE** Identifies the pin as open emitter.
  - OUT** Identifies the pin as an output.
  - PAS** Identifies the pin as passive.
  - PREFIX** Specifies the beginning of a prefix definition.
  - PWR** Identifies the pin as a power pin. The PWR keyword prevents a pin from displaying.

|           |  |
|-----------|--|
| REFERENCE | Takes an argument (a text string representing a reference value). Overrides the default reference value. |
| SHORT     | Specifies the pin lead lengths be 1 grid unit instead of the standard 3 grid units.                      |
| VECTOR    | Specifies the beginning of a part's vector definition.   |

---

## How syntax is described in this chapter

Syntax described in this chapter is shown following these conventions:

- UC      Text in uppercase represents a keyword.
- italics*      Text in italics represents either a character string or a numeric constant.
- [ ]      Text enclosed in brackets is optional. You choose whether to type it in or not. Don't type the brackets.
- { }      Text enclosed in braces is required. You must enter what's represented within the braces. Don't type the braces.
- ,      If items within square brackets or braces are separated by commas, you choose one of them only. Don't type the comma.
- . . .      Ellipses mean you can repeat the last item. How many times you can repeat the item depends on the context. Don't type the periods.

Vertical lists of options mean that you can choose any one of the options in the list.

Explanations follow each syntax definition. Within these definitions, keywords, character strings, and numeric constants are shown in the left margin with an arrow:

- ➔ **KEYWORD**      This is an example of a keyword definition.
- ➔ *Character string*      This is an example of a character string definition.
- ➔ *Numeric constant*      This is an example of a numeric constant definition.

**Example**      Here is an example of syntax represented in text:

[*pos pin#...grid...*]

The entire line is enclosed in brackets, which means it is optional. The *pos*, *pin#*, and *grid* parameters are in italics, so each must be replaced with a valid character string or numeric constant. The comma between *pin#* and *grid* specifies either *pin#* or *grid*, but not both, may be used on the same line. The ellipses following *pin#* and *grid* specify that more than one occurrence of *pin#* or *grid* may appear on the same line.



**Prefix definition**

PREFIX

[ 'prefix string' [= 'shorthand string' ]]

⋮

END

➔ *prefix string*

A string of up to seven text characters. You can have a maximum of sixteen prefix strings.

➔ *shorthand string*

A string of up to seven text characters.

△

**NOTE:** The equal sign may be separated by one or more space or tab characters.

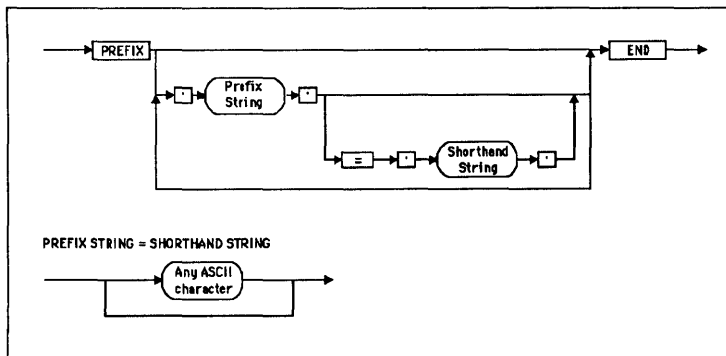

Figure 20-2. Syntax diagram for a prefix definition.

**Example 1**

```
PREFIX
'74LS' = 'LS'
'74S' = 'S'
'74ALS' = 'ALS'
'74AS' = 'AS'
'74HCT' = 'HCT'
'74HC' = 'HC'
'74ACT' = 'ACT'
'74AC' = 'AC'
'74F' = 'F'
'74'
END
```

**Example 2**

```
PREFIX
END
```

**Part definition**

'part name string'  
 [REFERENCE 'ref string']  
 [SHEETPATH 'path and filename']  
 {X-size Y-size parts-per-package}  
 [pin definition]  
 .  
 .  
 .  
 [bitmap definition]  
 [vector definition]  
 [converted form bitmap definition]  
 [converted form vector definition]

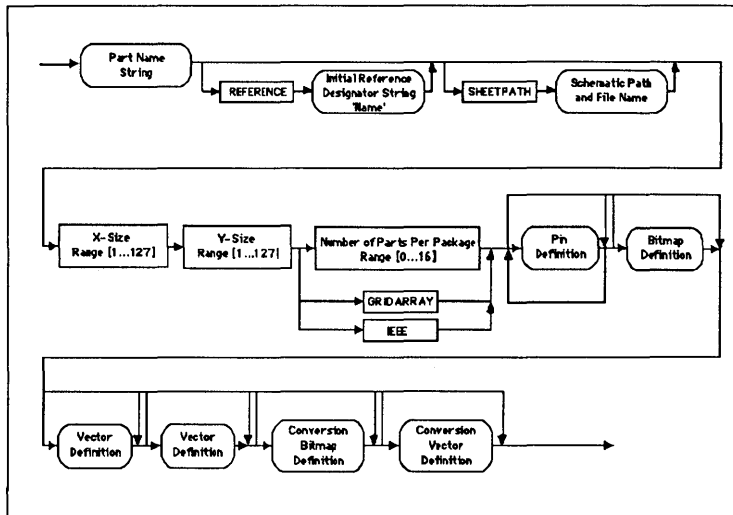

Figure 20-3. Syntax diagram of a part definition.

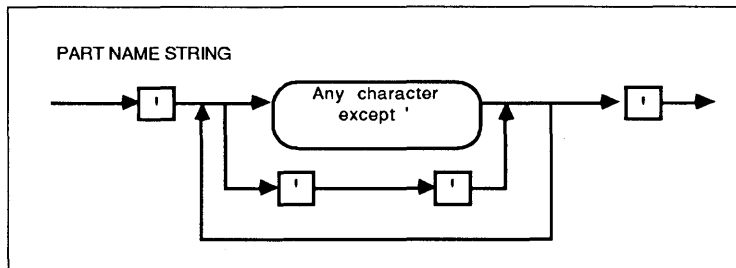

Figure 20-4. Syntax diagram of a part name string.

△ **NOTE:** To type an apostrophe, use two single quotes. For example, to type:

```
'John's'
type:
'John''s'
```

△ **NOTE:** To improve readability, you can include comments within a part definition. Comment text is enclosed within curly brackets. For example:

```
{This is a comment}
```

You can also place blank lines within a source file. Typically blank lines are placed between different part definitions.

➔ *part name string* A character string of up to 127 text characters identifying the part. This is the string used as an argument for the GET command in Draft.

It is a good idea to stay well below the maximum number of characters. Two reasons for this recommendation are:

- ❖ On a 640 x 480 screen, a name longer than 78 characters will have some characters clipped at zoom scale 1.
- ❖ While OrCAD's connectivity database is extremely flexible, some destination tools cannot accept long names. If you have a particular destination in mind, refer to the netlist format file for information about the limits of the destination tool. This information is available using the **View Reference Material** tool.

➔ *ref string* A string of text characters. If present, the reference designator replaces the default reference designator.

➔ *path and filename* The name of a schematic referenced by a sheetpath part.

➔ *X size* A numeric constant in the range 1 to 127. The horizontal size of the part as it appears on a printed worksheet. Each entry corresponds to one grid unit.

- ➔ *Y size* A numeric constant in the range 1 to 127. The vertical size of the part as it appears on a printed worksheet. Each entry corresponds to one grid unit.
  
- ➔ *parts-per-package* A numeric constant in the range 0 to 16. If you specify a 0, the pins are not numbered on the symbol. If you specify GRIDARRAY, an alphanumeric string of up to 15 characters enclosed in single quotes is allowed as pin numbers. If you specify IEEE, you automatically get one part per package.
  
- ➔ *pin definition* See the pin definition description later in this section.
  
- ➔ *bitmap definition* This definition describes the part body in bitmap form. See the bitmap definition description later in this section.
  
- ➔ *vector definition* This definition describes the part body in vector form. See the vector definition description later in this section.
  
- ➔ *converted form bitmap definition* This definition describes the part body of the part's converted form (for example, its DeMorgan equivalent) in bitmap form. See the converted form bitmap definition description later in this section.
  
- ➔ *converted form vector definition* This definition describes the part body of the part's convert (for example, its DeMorgan equivalent) in vector form. See the converted form vector definition description later in this section.  

These examples shows two part name strings. These may be on the same or separate lines.

**Example 1**      '2114'    '2148'  
                  6            14    1  
  
                  *pin definition*  
                  .  
                  .  
                  .

**Example 2**      '7474'  
                  '74ALS74'  
                  '74LS74'  
                  '74S74'  
                  '74HC74'  
                  '74AC74'  
                  6    6            2  
                  *pin definition*  
                  .  
                  .  
                  .



➔ *pos* Defines pin position. A letter followed by a number. The letter is one of the following:

T indicates the top of the symbol.

L indicates the left side of the symbol.

R indicates the right side of the symbol.

B indicates the bottom of the symbol.

The number represents the distance along the indicated side. The distance is measured in grid unit lengths. For example, if the block symbol were 6X by 10Y the grid used for placing pins is as follows. Figure 20-6 shows the location of L3.

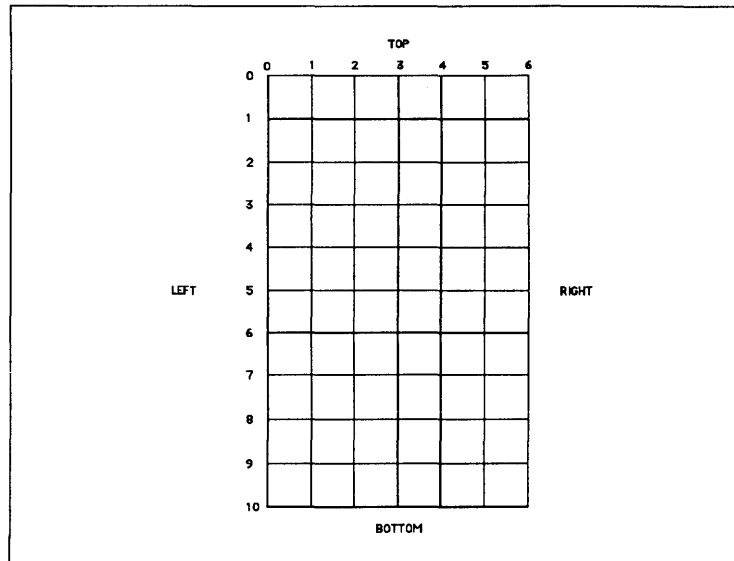

Figure 20-6. The grid of a 6X by 10Y block symbol.



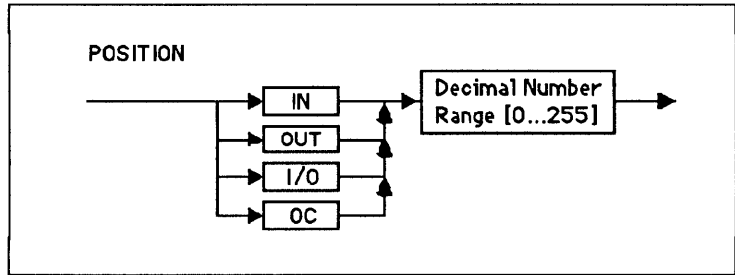

Figure 20-7. The Position syntax number diagram.

- ➔ *pin #* If present, this is a numeric constant representing the pin number. This is the pin number appearing in the symbol. The range for the pin numbers is 0 to 255.
- ➔ *grid* A letter followed by a number. *grid* represents the pin-grid array pin number (figure 20-8). You can only choose a pin-grid array pin number if you chose the keyword GRIDARRAY, instead of parts-per-package. A pin-grid array pin number is an alphanumeric string of up to 15 characters enclosed in single quotation marks.

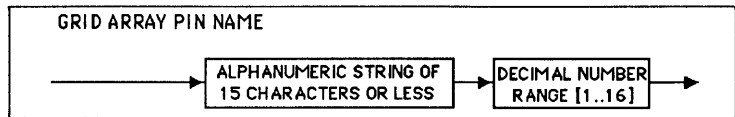
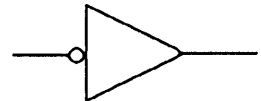
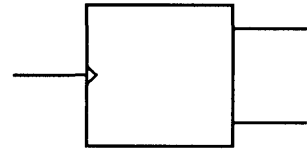

Figure 20-8. Gridarray pin number syntax diagram.

- ➔ **SHORT** A keyword that places a short lead at the specified pin. A normal lead is 3 grid units long; a SHORT one is 1 grid unit long. The SHORT keyword cannot describe a pin also having either the CLK or DOT keywords.
- ➔ **DOT** A keyword for placing the inversion symbol (the bubble, see right) at the specified pin location. The DOT keyword cannot describe a pin also having the SHORT keyword. The primary use of the bubble is to identify pins with logic negation, either at an input or at an output.



- ➔ **CLK** A keyword for placing the clock symbol (see right) at the specified pin location. The CLK keyword cannot describe a pin also having the SHORT keyword.



Use the CLK keyword together with the DOT keyword to produce a DOT CLK symbol (see right).

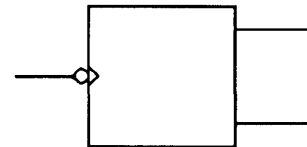

- ➔ **IN** A keyword identifying the pin as an input.
- ➔ **OUT** A keyword identifying the pin as a standard totem-pole output.
- ➔ **I/O** A keyword identifying the pin as a dual function input/output pin.
- ➔ **OC** A keyword identifying the pin as an open collector or open drain.
- ➔ **OE** A keyword identifying the pin as an open emitter.
- ➔ **PWR** A keyword identifying a power pin, such as VCC, GND, VSS, VDD, and others. Power pins are not displayed on library parts when they appear on the screen or printed worksheet. However, the connectivity database connects all power supply pins defined in library files.
- ➔ **PAS** A keyword identifying a pin as passive. Passive pins are typically pins on passive devices such as resistors, capacitors, inductors, and others.
- ➔ **HIZ** A keyword identifying a pin as a high-impedance (state) output.

- ➔ *pin name* A character string representing a name for the specified pin. For block symbols, this name appears on the screen or the printed worksheet. Pin names do not appear on the screen or the printed worksheet when they are part of pin definitions for a graphic symbol. However, you may still choose to use pin names in graphic symbols. The **Create Netlist** tool requires them, and you may find them useful to identify specific pins.

You can enter pin names either in upper- or in lowercase, but they always appear in uppercase.

The backslash (\) and single quote (') are special characters. A backslash (\) after a character indicates the character has a bar over it. If you want to bar multiple characters, you must place a backslash after each character. The single quote delimits the part name string. If you want a single quote as part of the pin string, you must delimit it with another single quote. Figure 20-9 shows the syntax for the pin name string.

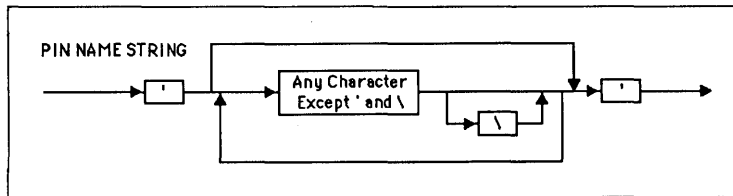

Figure 20-9. Pin name string syntax diagram.

**Example 1**

```
'2114' '2148'
6      14      1
L1     5      IN      'A0'
L2     6      IN      'A1'
L3     7      IN      'A2'
L4     4      IN      'A3'
L5     3      IN      'A4'
L6     2      IN      'A5'
L7     1      IN      'A6'
L8     17     IN      'A7'
L9     16     IN      'A8'
L10    15     IN      'A9'
L12    8      IN      'C\S\'
L13    10     IN      'W\E\'
R1     14     HIZ     'D0'
R2     13     HIZ     'D1'
R3     12     HIZ     'D2'
R4     11     HIZ     'D3'
T0     18     PWR     'VCC'
B0     9      PWR     'GND'
```

**Example 2**

```
'68020'
15     66     GRIDARRAY
L1     'C2'   CLK IN 'CLK'
      and so on
```

**Example 3**

```
'7474' '74ALS74' '74AS74' '74LS74'
'74S74' '74HC74' '74AC74'
6      6      2
L2     2      12     IN      'D'
L4     3      11     CLK IN 'CK'
B3     1      13     DOT IN 'CL'
      and so on
```

**Bitmap definition**

[ {.,#} ...,BITMAP 'part name' ,CONVERT 'part name' ]

·  
·  
·

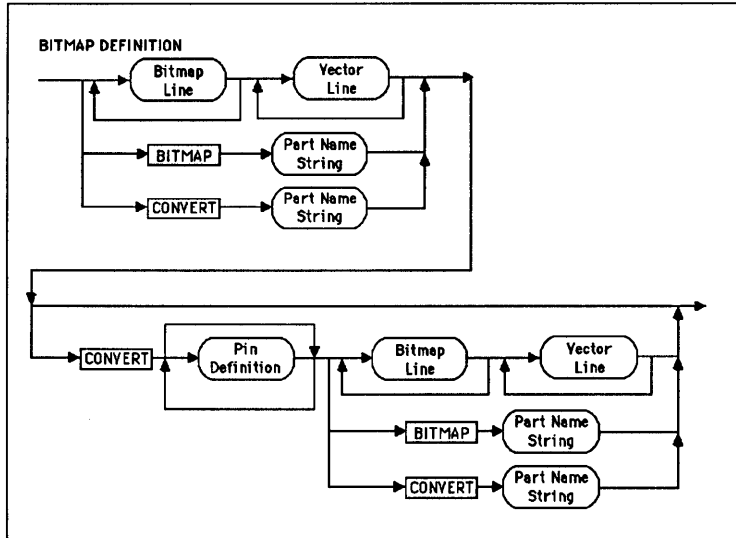

Figure 20-10. The bitmap syntax diagram.

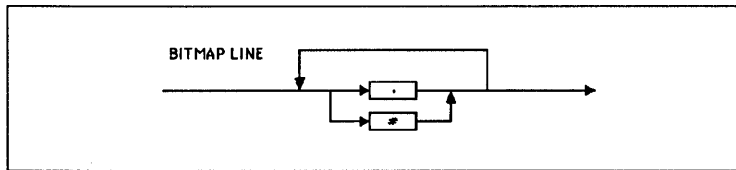

Figure 20-11. The bitmap line.

- ➡ . A . represents a cleared pixel bit not displayed on the screen.
- ➡ # A # represents a set pixel bit.

- *part name* A previously-defined part name with a bitmap. If you specify *part name* with the BITMAP keyword, the bitmap and vector definitions of the normal form of the previously-defined part are used. If you specify *part name* with the CONVERT keyword, the definitions of the converted form of the previously defined part are used.

Keep these limitations in mind:

- ❖ Maximum bitmap size is 16384 pixels.
- ❖ Each pixel represents 0.1 of a grid unit. Therefore, it takes 10 bitmap pixels to represent one grid unit. Remember, pin placement is determined according to grid units.  
  
For example, L0 identifies a pin on the left side of the bitmap line in the zero position. L1 identifies a pin on the left side of the tenth bitmap line. Pin placements are at lines 0, 10, 20, 30, etc.
- ❖ The lines and character positions of a bitmap start numbering at 0. Hence, a symbol with X=2 and Y=3 has 21 lines, each with 31 character positions.
- ❖ If a line contains only periods (a clear line), you need only place a period in the first column.
- ❖ You need not include clear lines (lines containing only periods) at the end of a bitmap.
- ❖ Periods are not required after the last # in a line.
- ❖ If you use the BITMAP 'part name' option, be sure the part name you refer to is previously defined.

**Example 1**

Notice how comments -----  
are used to label both  
the horizontal and  
vertical axis.

```
'CAPACITOR'
Reference 'C'
{X Size =} 2 {Y Size =} 1 {Parts per Package =} 0
T1  SHORT  PAS '1'
B1  SHORT  PAS '2'
      {000000000011111111112}
      {.....}
      {012345678901234567890}
{ 0.0}#####
{ 0.1}.....
{ 0.2}.....
{ 0.3}.....
{ 0.4}.....#####
{ 0.5}...###...#...###...
{ 0.6}.###.....#.....###.
{ 0.7}##.....#.....##
{ 0.8}.....#.....
{ 0.9}.....#.....
{ 1.0}.....#.....
VECTOR
LINE  +0.0 +0.0 +2.0 +0.0
LINE  +1.0 +0.4 +1.0 +1.0
ARC   +1.0 +2.0 +1.0 -1.3 +0.0 -1.6 +1.6
ARC   +1.0 +2.0 +0.0 -1.6 -1.0 -1.3 +1.6
END
```

**Example 2**

```
BITMAP '7400'
```

This uses the bitmap and vector definitions for the normal form of the 7400 device.

**Example 3**

```
CONVERT '7400'
```

This uses the bitmap and vector definitions for the converted form of the 7400 device. The 7400 part must have a converted form if the library source file is to compile without errors.

**Vector definition**

|        |             |             |                         |            |            |            |
|--------|-------------|-------------|-------------------------|------------|------------|------------|
| VECTOR |             |             |                         |            |            |            |
| ARC    | X<br>center | Y<br>center | X<br>edge1              | Y<br>edge1 | X<br>edge2 | Y<br>edge2 |
| CIRCLE | X<br>center | Y<br>center | radius                  |            |            |            |
| FILL   | X<br>start  | Y<br>start  |                         |            |            |            |
| LINE   | X<br>start  | Y<br>start  | X<br>end                | Y<br>end   |            |            |
| TEXT   | X<br>start  | Y<br>start  | height {'text'/keyword} |            |            |            |
| END    |             |             |                         |            |            |            |

△ *NOTE: If you use the BITMAP 'part name' option (as described in the "Bitmap Definition" section), you don't need to specify a separate vector definition. The bitmap and vector definitions of the part referred to by part name are used.*

➔ ARC An ARC line defines a section of a circle. The first pair of X,Y coordinates specifies the center of the circle from which the arc is taken. The second pair of X,Y coordinates (edge1) defines one ending point on the arc. The third pair of X,Y coordinates (edge2) defines the other ending point on the arc. The edge1 and edge2 coordinates are relative to the center of the circle; they are not absolute coordinates.

➔ CIRCLE The X,Y coordinates specify the center of the circle. *radius* specifies the distance from the center to the outside of the circle.

➔ LINE The first pair of X,Y coordinates specifies the beginning of the line. The second pair of X,Y coordinates specifies the end of the line.



- FILL FILL shades the enclosed area around the X,Y coordinates. One use of FILL is to darken the triangular shape in the symbol of a diode.
  
- TEXT The X,Y coordinates specify the point at which the lower left corner of the first character of the text starts. *height* defines the multiplier of the text size defined in the template table on the **Configure Schematic Design Tools** screen. For example, if pin text is set to 0.06 inches in the template table, and the height is 2, then the actual plotted height is 0.12 inch. The remainder of the TEXT line can be either text enclosed in single quotes or a keyword.

Keywords are IEEE/ANSI special symbols. If you use one of these keywords, the symbol corresponding to the keyword appears instead of text. Possible keywords are:

|               |             |
|---------------|-------------|
| ACTIVE_LOW_L  | HYSTERESIS  |
| ACTIVE_LOW_R  | NON_LOGIC   |
| AMP_L         | OPEN_O      |
| AMP_R         | OPEN_H      |
| ANALOG        | OPEN_L      |
| ARROW_L       | POSTPONED   |
| ARROW_R       | PULL_UP     |
| BIDIRECTIONAL | PULL_DOWN   |
| DYNAMIC_L     | SHIFT_L     |
| DYNAMIC_R     | SHIFT_R     |
| GENERATOR     | THREE_STATE |

For more information about these symbols, see ANSI/IEEE Std 91-1984.

## Converted form definition

```

CONVERT
[pin definitions]
.
.
.
[[BITMAP 'part name', CONVERT 'part name'],
[bitmap definition]
[vector definition]]

```

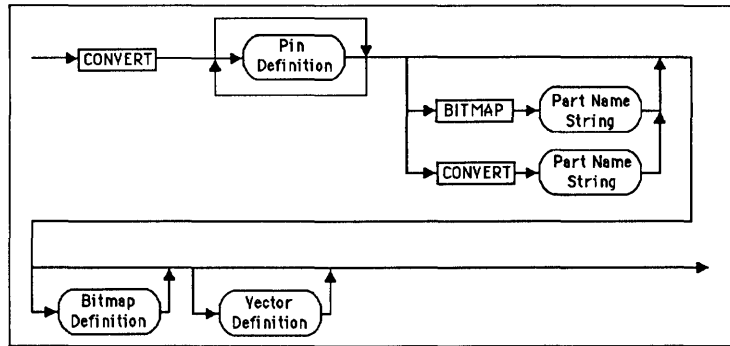

Figure 20-12. Converted form syntax diagram.

- ➔ *part name*      The part name of a previously-defined part. If you specify part name with the BITMAP keyword, the bitmap and vector definitions of the normal form of the previously-defined part are used. If you specify part name with the CONVERT keyword, the definitions of the converted form of the previously defined part are used.
- ➔ *pin definition*      See the pin definition description earlier in this section. Note the pin definition for a converted bitmap has the same value for parts-per-package as the normal bitmap.
- ➔ *bitmap definition*      This specifies a new bitmap for the converted form of the part. See the bitmap definition description earlier in this section. If you use bitmap definition, do not use the BITMAP or CONVERT keywords.

➤ *vector definition* This specifies a new vector for the converted form of the part. See the vector definition description earlier in this section. If you use vector definition, do not use the BITMAP or CONVERT keywords.

△ **NOTE:** *If you use the CONVERT 'part name' option, be sure the part name you refer to is previously defined.*



## *Compile Library*

---

### Execution

**Compile Library** takes a library source file and produces a compiled library file used by the schematic editor, processors, reporters, and transfers.

#### Creating a custom library with **Compile Library**

A custom library is a library that you modify or create. To create a custom library with **Compile Library**, follow these two steps:

1. Create a library source file. The source file is a text file containing instructions in OrCAD's Symbol Description Language (described in chapter 20).

You can use any text editor to create the library source file. The only requirement is that it produce a text file without hidden formatting characters.

You can also use the **Archive Parts in Schematic** tool to create a library source file. Another way to get a library source file is to use **Decompile Library** or an existing library.

2. Compile the source file using the **Compile Library** tool. It produces a compiled library file.

△ **NOTE:** The maximum length for a part name is 127 characters. Use much smaller part names if you possibly can, however. On a 640 x 480 screen at ZOOM level 1, a name longer than 78 characters will be clipped. Also, many netlist formats place severe restraints on the length of names. Check the name length requirements for the netlist format you are using. This information is available using the *View Reference Material* tool.

### Running Compile Library

With the Schematic Design Tools screen displayed, select **Compile Library**. Select **Execute** from the menu that displays.

**Compile Library** creates the new library. When **Compile Library** is complete, the Schematic Design Tools screen appears.

---

### Local Configuration

With the Schematic Design Tools screen displayed, select **Compile Library**. Select **Local Configuration** from the menu that displays.

Select **Configure COMPOSER**. A configuration screen appears (figure 21-1).

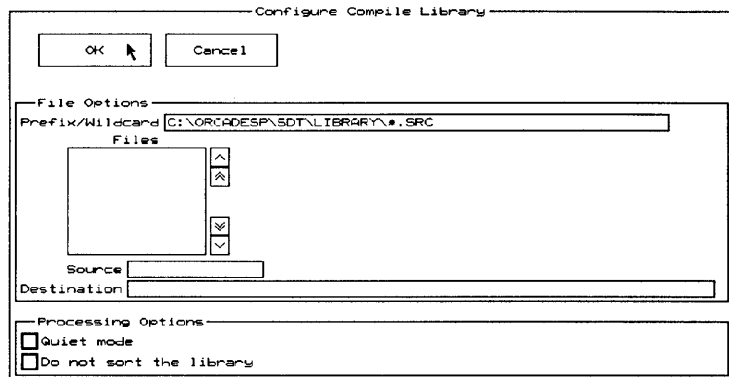

Figure 21-1. Compile Library's local configuration screen.

### File Options

**File Options** defines the library source file and the resulting library file.

**Prefix/Wildcard**

Enter a pathname and wildcard to indicate which files to display in the list box with scroll buttons. The asterisk character (\*) is used as a wildcard. The default is:

\ORCADESP\SDT\LIBRARY\\*.SRC

If you do not specify a prefix, **Compile Library** looks for files in the current design directory.

If you erase the entire field, the entry will be restored to whatever prefix is specified in **Configure Schematic Design Tools**.

**Files**

The files that match the search filter entered in the **Prefix/Wildcard** entry box and those that match the filter in the current design directory are listed in this box. Files in the current directory are shown with .\ before their names. Use the scroll buttons to scroll the list of files up and down.

When you see the file you would like to compile, select it. Its filename displays in the **Source** entry box.

**Source**

The **Source** is the text file describing your custom parts using OrCAD's Symbol Description Language.

Specify the source file by selecting it from the **Files** list box described above, or enter its name by simply typing it in this entry box and pressing <Enter>.



**NOTE:** A question mark (?) in an entry box tells ESP to default to the **Startup Design** name. This simplifies changing between designs: All you need do is change the **Startup Design** on the **Configure ESP** screen, exit ESP, then restart ESP by entering ORCAD.

For example, if you enter ?.SRC in the **Source** entry box and the **Startup Design** is configured as "TUTOR," the next time you look at the local configuration, the **Source** entry box will be configured as "TUTOR.SRC." If you then change the **Startup Design** to "DESIGN2" and restart ESP, the **Source** entry box will be configured as "DESIGN2.SRC."

*Destination*    **The Destination** is the library file created by **Compile Library**. If you give the name of an existing file, **Compile Library** asks if you want to overwrite the existing file. You cannot append to an existing file.

The **Destination** may be a complete pathname.

**Processing Options**    You may select either or both of the following options:

Quiet mode

Turns quiet mode on.

Do not sort library

Tells **Compile Library** to save parts in the source file in the order they were entered (rather than sorting them alphabetically, which is the default).

# P A R T V : R E P O R T E R S

---

Reporters are tools that produce human-readable reports, but do not modify design data in any way.

Part V describes the Reporter tools that change the design to a format you can read.

*Chapter 22: Check Electrical Rules* describes how **Check Electrical Rules** checks a design for conformity to basic electrical rules.

*Chapter 23: Cross Reference Parts* describes how **Cross Reference Parts** scans through the design, gathers information for all parts used in the design, and creates a cross reference listing telling you where each part is located.

*Chapter 24: Convert Plot to IGES* describes how **Convert Plot to IGES** translates a plot of a single worksheet or a complete design into IGES format.

*Chapter 25: Plot Schematic* describes how **Plot Schematic** plots designs.

*Chapter 26: Print Schematic* describes how **Print Schematic** prints designs.

*Chapter 27: Create Bill of Materials* describes how **Create Bill of Materials** creates a summary list of all parts used in a design.

*Chapter 28: Show Schematic Structure* describes how **Show Schematic Structure** scans the worksheets in a design and displays the sheet names and their associated worksheet filenames.







## Check Electrical Rules

---

### Execution

The **Check Electrical Rules** reporter checks a design for conformity to basic electrical rules. It does not check for other types of errors in your design.

**Check Electrical Rules** scans a design and checks the sheets for unused inputs on parts and invalid connections, such as two part pins defined as outputs wired together. An example of the electrical rules checked by this reporter is included at the end of this chapter. **Check Electrical Rules** reports two categories of electrical rules violations:

- ❖ Errors that *must* be fixed
- ❖ Warnings of situations that may or may not be all right in your design

Always carefully examine any problems reported by **Check Electrical Rules**.

You specify the conditions to be checked using the **Check Electrical Rules matrix** on the **Configure Schematic Design Tools** screen. See *How to specify conditions to check* in this chapter for more details.

Unless you tell it otherwise on the configuration screen, **Check Electrical Rules** is incremental. This means that if you run **Check Electrical Rules** twice on the same design without fixing anything, no errors are reported the second time it runs since there is nothing new to report.

If **Check Electrical Rules** finds warnings or errors, it marks them in the schematic file. If **Check Electrical Rules** reports "Program did not complete successfully." after running, go to **Draft** to fix the errors. Every warning or error is marked with a circle as shown in the figure below. Note that the wire coming from pin 5 on U1B and the wire coming from pin 3 of U1A have circles on them.

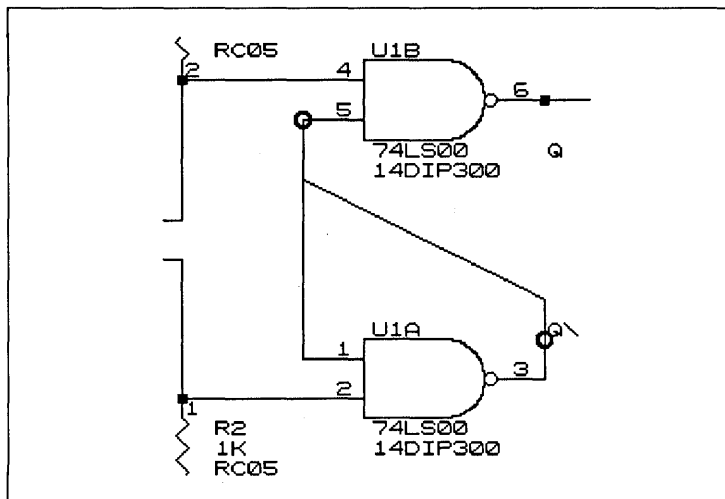

Schematic file with two warnings marked with circles.

*Find and repair errors*

Use the **INQUIRE** command to see the error message or warning for any trouble spots. Fix the problems, update the schematic file, and run **Check Electrical Rules** again.

*Discard error markers*

To discard error markers without making any changes to the schematic, select **QUIT Update File**.

**Running Check Electrical Rules**

Select **Check Electrical Rules** from the **Schematic Design Tools** screen. Select **Execute** from the menu that displays.

While **Check Electrical Rules** runs, messages display in the monitor box at the bottom of the screen. When it is done, the **Schematic Design Tools** screen appears.

Typical messages and resolutions

Table 22-1 on the next page lists the most common error messages produced by Check Electrical Rules and possible solutions to resolve the errors.

How to specify conditions to check

Figure 22-1 shows the decision matrix that tells Check Electrical Rules the conditions to check for when evaluating connections between pins, module ports, and sheet net names.

To configure the decision matrix to check for certain conditions, go to the Check Electrical Rules Matrix section of the Configure Schematic Design Tools screen. For more information on Configure Schematic Design Tools, see Chapter 1: Configure Schematic Tools.

The matrix shows the pins, module ports, and sheet net names in columns and rows. A connection is represented by the intersection of a row and column. The intersection of a row and column is either empty, or contains a "W," or an "E." An empty intersection represents a valid connection, a W is a warning, and E represents an error.

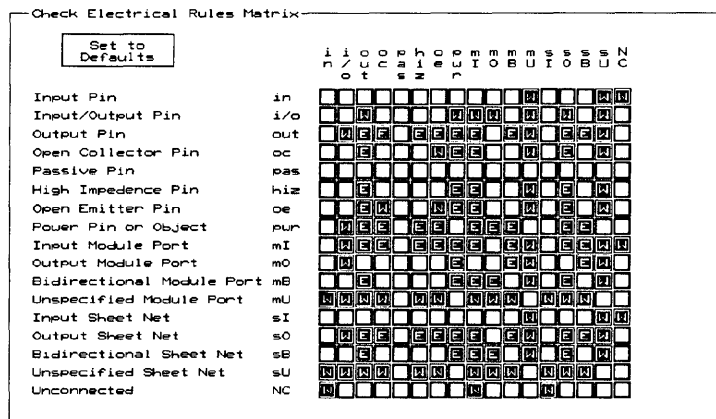

Figure 22-1. The decision matrix used by Check Electrical Rules to check a connection.

| <i>Message</i>   | <i>Check for</i>   |
|--|--|
| WARNING: Unconnected MODULE PORT "....." at X=.... at Y=...                      | A bus may not be labeled properly. It must be named in the form: BUSNAME[m..n]. Any module port connected to a bus must also be named in the proper form: BUSNAME[m..n]. For further information, see <i>Chapter 9: Creating a netlist</i> .   |
| WARNING: POWER Supplies are CONNECTED .... <-> ....                              | If you connected two power supplies together, this warning appears. This condition may be acceptable in your design.<br><br>If you did not mean to connect two power supplies together, this indicates a problem may exist. If you intentionally connected two power supplies together, you may ignore this warning.   |
| WARNING: INPUT has NO Driving Source ....  | If you did not connect wires to the input pins of a library part, this warning appears. Again, this condition may be acceptable in your design.<br><br>If wires are connected to an input pin and this message appears, you may have two wire ends overlapping or a wire overlapping a part pin. Wires must be connected end-to-end.<br><br>If you intentionally did not connect wires to the input pins of a library part, you may ignore this warning. |
| ERROR: Module Port on a bus does not have a proper format....can not process.... | When a module port is connected to a bus, it must be in the format: BUSNAME[m..n].   |
| ERROR: Bus Label does not have a proper format....can not process...             | When a label is placed on a bus, it must be in the format: BUSNAME[m..n].  |
| ERROR: Sheet Net on a bus does not have a proper format... can not process...    | This error typically results from a bus connected to a hierarchical sheet net. The sheet net and module port must have the same name and number of members, but the sheet net and bus may differ at the root level. The form should be: BUSNAME[m..n].   |

Table 22-1. Error messages created by Check Electrical Rules and possible solutions.

You can toggle between these three settings by pointing to an intersection and clicking the mouse until the desired setting appears. To return all intersections to their default settings, click the **Set to Default** button.

For example, if you have an output pin connected to an input pin, find the **Check Electrical Rules** value in the matrix by starting in the OUT column (the third column) and going down to the IN row (the first row). The box is empty, which represents an acceptable connection.

However, if you follow the OUT column down to the OUT row (the third row), you see an E, which indicates this condition will be detected as an error.

Connections prefixed with an “m” are module ports. You can have four types of module ports: input (mI), output (mO), bidirectional (mB), and unspecified (mU).

Connections prefixed with an “s” are sheet net names. As with module ports, you can have four types of sheet net names: input (sI), output (sO), bidirectional (sB), and unspecified (sU).

NC means Not Connected.

For definitions of the pin types, see the **PIN Type** command description in *Chapter 2: Draft*.

**Example** The following example shows the type of errors **Check Electrical Rules** looks for in schematic sheets. Figure 22-2 shows a schematic sheet containing a 74LS245 part from the TTL.LIB library. Notice pins 2, 3, 4, 7, and 8 are tied together and pins 5, 6, and 9 are tied together. These connections are electrically sound because pins 2 through 9 are bidirectional (I/O) type pins. Though this may not be a particularly useful circuit, it doesn't violate any electrical rules, so **Check Electrical Rules** doesn't report any errors.

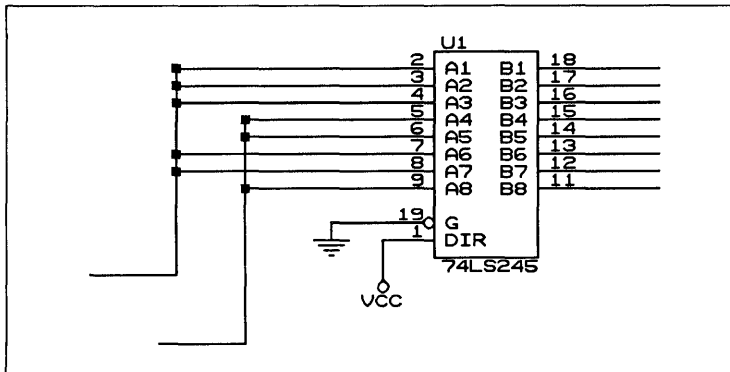

Figure 22-2. Example circuit for Check Electrical Rules (without 74LS00).

Suppose you add a 74LS00 part (also from TTL.LIB) to the sheet shown in figure 22-3. This introduces two potential electrical violations to the sheet because pin 6 on U2B and pin 3 on U2A are output type pins. Output pins usually are not connected to bidirectional pins. If you run **Check Electrical Rules** on the design with the decision matrix set to its defaults, it reports the following warnings:

```
Warning, Possible conflict I/O connected TO OUTPUT U2B,0
Warning, Possible conflict I/O connected TO OUTPUT U2A,0
WARNING - INPUT has NO Driving Source U2B,I0
WARNING - INPUT has NO Driving Source U2B,I1
WARNING - INPUT has NO Driving Source U2A,I0
WARNING - INPUT has NO Driving Source U2A,I1
```

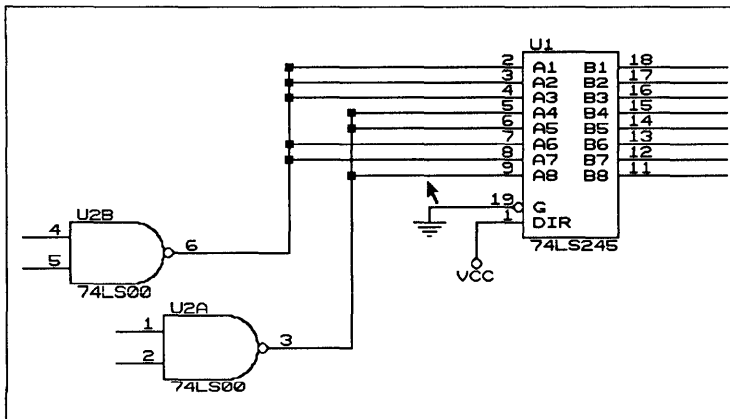

Figure 22-3. Example circuit for Check Electrical Rules (with 74LS00).

## Local Configuration

With the **Schematic Design Tools** screen displayed, select **Check Electrical Rules**. Select **Local Configuration** from the menu that displays.

Select **Configure ERC**. A configuration screen appears (figure 22-4).

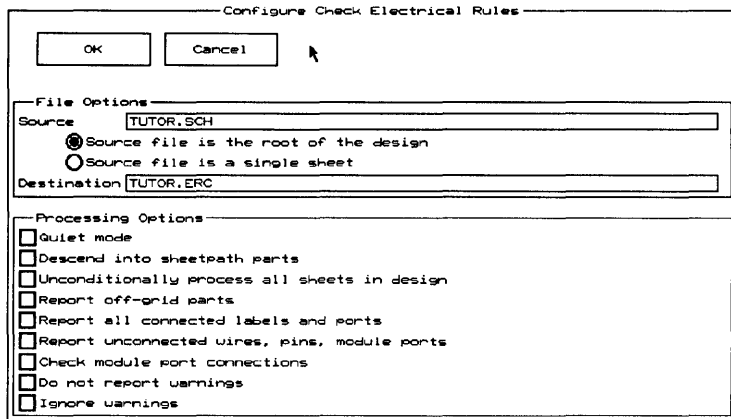

Figure 22-4. Check Electrical Rules's local configuration screen.

### File Options

**File Options** defines the source file, its type, and the destination file.

#### Source

The **Source** can be the root sheet name of the design, or the filename of a single sheet. It may have any valid pathname.



**NOTE:** To have ESP configure the source filename for you, enter a question mark instead of the filename, followed by the file extension. For example, if you enter *? .SCH*, ESP changes the *?* to the name of the *Startup Design* (configured in the *Design Options* section of the *Configure ESP* screen) when you leave the local configuration screen.



After entering the source filename, select one of the following options:

- Source file is the root of the design  
Specifies that the source file is the root sheet name of a hierarchical or flat design. If the root sheet contains sheet symbols, then the design is hierarchical. If it contains a |Link, it is a flat design.
- Source file is a single sheet  
Specifies that the source file is a single worksheet and you want to process the single sheet only.

*Destination* The **Destination** can be any valid path name where the list of errors is to be placed. If a destination is not specified, the list of errors display in the monitor box at the bottom of the screen.

△ ***NOTE:** The errors and warnings are automatically saved to the schematic. The destination would be used for review, but is optional.*

**Processing Options** You may select any combination of the following options:

- Quiet mode  
Turns quiet mode on.
- Descend into sheetpath parts  
Causes **Check Electrical Rules** to descend into any parts defined as sheetpath parts. If this option is not selected, **Check Electrical Rules** treats the sheetpath itself as a part to be cross-referenced and does not cross reference the parts within a sheetpath.

- ❑ Unconditionally process all sheets in design  
Forces **Check Electrical Rules** to check all sheets in the design regardless of whether or not the sheets changed since **Check Electrical Rules** ran last.
- ❑ Report off-grid parts  
Lists all off-grid parts in the report.
- ❑ Report all connected labels and ports  
Lists all connected labels and ports in the report.
- ❑ Report unconnected wires, pins, module ports  
Lists all unconnected wires, pins, and module ports in the report.
- ❑ Check module port connections  
Causes **Check Electrical Rules** to check all module ports and make sure they have a corresponding connection.
- ❑ Do not report warnings  
Causes **Check Electrical Rules** to run without reporting warnings.
- ❑ Ignore warnings  
Causes **Check Electrical Rules** to continue running when it encounters warnings, instead of halting in the middle of execution.





## *Cross Reference Parts*

---

### Execution

The **Cross Reference Parts** reporter scans through the specified schematic files, gathers information for all parts used in the schematic files, and creates a cross reference listing telling you where each part is located. **Cross Reference Parts** scans a multiple-sheet file structure or a one sheet file structure.

By default, **Cross Reference Parts** produces two types of output listings. These listings differ in the order in which the parts are sorted. The first type of listing is sorted first by part values, then by reference designators. The second type of listing is sorted first by reference designators, then by part values.

### Running Cross Reference Parts

Select **Cross Reference Parts** from the **Schematic Design Tools** screen. Select **Execute** from the menu that displays.

While **Cross Reference Parts** runs, messages display in the monitor box at the bottom of the screen. When the report is complete, the **Schematic Design Tools** screen appears.

**Sample Output** Figure 23-1 shows a sample report created by **Cross Reference Parts**.

| Generic Netlist Example |           |         | Revised: October 11, 1990 |          |          |
|-------------------------|-----------|---------|---------------------------|----------|----------|
| OrCAD-01                |           |         | Revision: A               |          |          |
| Cross Reference         |           |         | October 12, 1990          | 15:24:03 | Page 1   |
| Item                    | Reference | Part    | SheetName                 | Sheet    | Filename |
| 1                       | R1        | 1K      | <<<root>>>                | 1        | EX1.SCH  |
| 2                       | R2        | 1K      | <<<root>>>                | 1        | EX1.SCH  |
| 3                       | S1        | SW SPDT | <<<root>>>                | 1        | EX1.SCH  |
| 4                       | U1A       | 74LS00  | <<<root>>>                | 1        | EX1.SCH  |
| 5                       | U1B       | 74LS00  | <<<root>>>                | 1        | EX1.SCH  |

Figure 23-1. Report created by *Cross Reference Parts*.

## Local Configuration

With the Schematic Design Tools screen displayed, select **Cross Reference Parts**. Select **Local Configuration** from the menu that displays.

Select **Configure CROSSREF**. A configuration screen displays (figure 23-2).

Figure 23-2. Local configuration screen for *Cross Reference Parts*.

**File Options**     **File Options** defines the source file, its type, and the destination file.

*Source*     The **Source** can be the name of the root sheet of the design, or the filename of a single sheet. It may have any valid pathname.

△     ***NOTE:** To have ESP configure the source filename for you, enter a question mark instead of the filename, followed by the file extension. For example, if you enter **? .SCH**, ESP changes the **?** to the name of the **Startup Design** (configured in the **Design Options** section of the **Configure ESP** screen) when you leave the local configuration screen.*

After entering the **Source**, select one of the following:

- Source file is the root of the design  
Specifies that the source file is the root sheet name of a hierarchical or flat design. If the root sheet contains sheet symbols, then the design is hierarchical. If it contains a |Link, it is a flat design.
- Source file is a single sheet  
Specifies that the source file is a single worksheet and you want to process the single sheet only.

*Destination*     The **Destination** can be any valid path name where the listings are to be placed. If a **Destination** is not specified, the listings are displayed in the monitor box at the bottom of the screen.

- Processing Options** You may select any combination of the following options:
- Quiet mode  
Turns quiet mode on.
  - Descend into sheetpath parts  
Causes **Cross Reference Parts** to descend into any parts defined as sheetpath parts. If this option is not selected, **Cross Reference Parts** treats the sheetpath itself as a part to be cross referenced and does not cross reference the parts within a sheetpath.
  - Report identical part reference designators  
Tells **Cross Reference Parts** to check for identical part references in addition to creating the usual report. You should not have identical part references in your design. Remove them by editing them with **Draft** or running **Annotate Schematic**.
  - Report unused parts in multiple-part packages  
Tells **Cross Reference Parts** to list all unused parts in multiple-part packages in addition to its usual report.
  - Report the X, Y coordinates of all parts  
Tells **Cross Reference Parts** to list the X,Y coordinates for all parts.
  - Place each part entry on a separate line  
Tells **Cross Reference Parts** to place each part entry on a separate line.

Report type mismatch parts

Tells **Cross Reference Parts** to report type mismatches in addition to the usual report. Two kinds of mismatches are possible:

- ❖ Parts with the same part name, but different numbers of parts per package.

For example, a U1 and a U1A. This would mean that the U1 has one part per package, while the U1A has more than one part per package.

- ❖ Parts with similar reference numbers, but different part names.

For example, a 74LS00 with the reference number U1A and a 54LS00 with reference number U1B.

Select either of the following options:

- Sort output by part value, then by reference designator

Tells **Cross Reference Parts** to list all parts sorted first by part values and then by reference designators.

- Sort output by reference designator

Tells **Cross Reference Parts** to list all parts sorted first by reference designators and then by part values.

Select either of the following options to specify whether or not to place a header on each page of the report:

- Insert a header for each page
- Do not insert a header for each page



Select either of the following options to specify whether the report is single- or double-spaced:

Report is

- single-spaced
- double-spaced

If desired, select this option:

- Ignore warnings

Causes **Cross Reference Parts** to continue running when it encounters warnings, instead of halting in the middle of execution.



## *Convert Plot to IGES*

---

### Execution

**Convert Plot to IGES** translates a plot of a single worksheet or a complete design into *IGES*, Initial Graphic Exchange Specification, text format. The IGES data format is application-independent and includes information about geometric and topological shapes, physical dimensions, tolerances, and other intrinsic properties.

To learn more about IGES, read the *Initial Graphics Exchange Specification (IGES) Version 3.0, Number PB86-199759*, published by the National Bureau of Standards, Washington D.C.

After you run **Convert Plot to IGES**, the file can be used with other applications that accept IGES input—such as VersaCad®—or stored on a mainframe computer.

### Plot the file

Before you run **Convert Plot to IGES**, plot your worksheet with the **GENERIC.DRV** plotter driver configured. See *Chapter 1: Configure Schematic Tools* and *Chapter 25: Plot Schematic* for information on configuring plotter drivers and plotting.

### Running Convert Plot to IGES

With the **Schematic Design Tools** screen displayed, select **Convert Plot to IGES**. A menu displays. Select **Execute**.

While **Convert Plot to IGES** runs, messages display in the monitor box at the bottom of the screen. When the report is complete, the bottom of the **Schematic Design Tools** screen displays.

Sample output Figure 24-1 shows a sample report created by Convert Plot to IGES.

|   |    |    |    |   |           |   |
|---|----|----|----|---|-----------|---|
| IGES file generated from OrCAD Schematic Design Tools                     |    |    |    |   | S         | 1 |
| ,,21HOrCAD IGES Translator,,5HOrCAD,4HIGES,16,11,53,11,53,,1.0,3,4HINCH,G |    |    |    |   | G         | 1 |
| 30,0.46785,6H000001,,8HIGESTRAN,5HOrCAD,6,0;                              |    |    |    |   | G         | 2 |
| 110   | 1  | 1  | 1  | 1 | 00000000D | 1 |
| 110   | 1  | 1  | 1  |   | new D     | 2 |
| 110   | 2  | 1  | 1  | 1 | 00000000D | 3 |
| 110   | 1  | 1  | 1  |   | new D     | 4 |
| 110   | 3  | 1  | 1  | 1 | 00000000D | 5 |
| 110   | 1  | 1  | 1  |   | new D     | 6 |
| 110   | 4  | 1  | 1  | 1 | 00000000D | 7 |
| 110   | 1  | 1  | 1  |   | new D     | 8 |
| 110,0.77,0.583,.0,0.77,0.517,.0;  |    |    |    |   | 1P        | 1 |
| 110,0.93,0.583,.0,0.77,0.583,.0;  |    |    |    |   | 3P        | 2 |
| 110,0.93,0.517,.0,0.93,0.583,.0;  |    |    |    |   | 5P        | 3 |
| 110,0.77,0.517,.0,0.93,0.517,.0;  |    |    |    |   | 7P        | 4 |
| S   | 1G | 2D | 8P | 4 | T         | 1 |

Figure 24-1. Output created by Convert Plot to IGES.

## Local Configuration

With the **Schematic Design Tools** screen displayed, select **Convert Plot to IGES**. Select **Local Configuration** from the menu that displays.

Select **Configure PLT2IGES**. A configuration screen appears (figure 24-2).

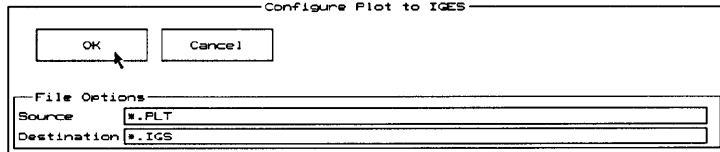

Figure 24-2. Convert Plot to IGES's local configuration screen.

**File Options** **File Options** defines the source file and the destination of the IGES plot.

*Source* The **Source** is the name of the plot file or group of plot files to be translated into IGES format.

The source may be a single plot file or a wildcard specification. The suggested wildcard specification is `*.PLT`. When **Plot Schematic** runs, it should be configured with a destination of `?.PLT` so that all of the sheets will be ready to convert to IGES format.

*Destination* The **Destination** is any valid path name where the output of **Convert Plot to IGES** is to be placed.

If the source is a wildcard specification, the destination should also be a wildcard specification. The suggested destination wildcard specification is `*.IGS`.





## *Plot Schematic*

---

### Execution

Plot Schematic plots schematic sheets.

There are two types of output devices that can be used with **OrCAD Schematic Design Tools**: plotters and printers. These devices are categorized by the type of input they require.

If a device accepts *vector* commands, it is considered to be a plotter. A vector is a series of points with a specific function defined. For example, a line has a beginning point and an ending point. A circle has a center and a radius. The device needs to know what the vector information is but does not need every point along the vector.

If a device accepts *raster* commands, it is a printer. A raster is an array of dots. When you draw a line to a raster device, you must specify each and every dot.

Plots are higher resolution than prints and usually take longer to produce (because there is more mathematical calculation needed). For these reasons, use **Plot Schematic** to plot the schematic when design work is complete. Use **Print Schematic** (described in chapter 26) to print working copies of your schematic during the design process.

**Plot Schematic** can plot all sheets in a multiple-sheet file structure or just one sheet. It makes one copy of each sheet referenced more than once in a complex hierarchy.

Be sure plotter is  
configured

Before you run **Plot Schematic**, be sure the appropriate plotter is configured on the **Configure Schematic Design Tools** screen. For more information about configuring your plotter, see *Chapter 1: Configure Schematic Tools*.

**Running Plot Schematic**

With the **Schematic Design Tools** screen displayed, select **Plot Schematic**. Select **Execute** from the menu that displays.

While **Plot Schematic** runs, messages display in the monitor box at the bottom of the screen. When **Plot Schematic** completes the plot, the **Schematic Design Tools** screen appears.

Plots can include grid references in the output. **Plot Schematic** plots all Stimulus, Trace, Vector, Layout, and No-Connect objects.



*NOTE: Plot Schematic does not check to see if the plot will fit in the plot area of a plotter, nor does it split a design into several pages on a plotter if its image does not fit on a single page. If you choose the **Send output to printer** option, however, Plot Schematic prints a large image on multiple sheets.*

**Suppressing the title block, border, and text**

You can make **Draft** and **Configure Schematic Design Tools** cause the title block, title block text, and the design's border to not appear on the plot. These settings are summarized below.

- ❖ To cause the title block and its text to not appear on **Draft's** screen, select **SET Title Block No in Draft**. Note that the design's border is not removed.
- ❖ To cause the title block or title text to not appear on a plot, display the **Color and Pen Plotter Table** of the **Configure Schematic Design Tools** screen and set the pen number to 99 for the title block or the title text. If you set the title block's pen number to 99, the design's border is also removed from the plot.
- ❖ To cause the title block or title text to not appear on **Draft's** screen, display the **Color and Pen Plotter Table** of the **Configure Schematic Design Tools** screen and set the color to black for the title block or the title text. With the title block's color set to black, the design's border does not show on **Draft's** screen.

Sample output Figure 25-1 shows a sample plot created by Plot Schematic.

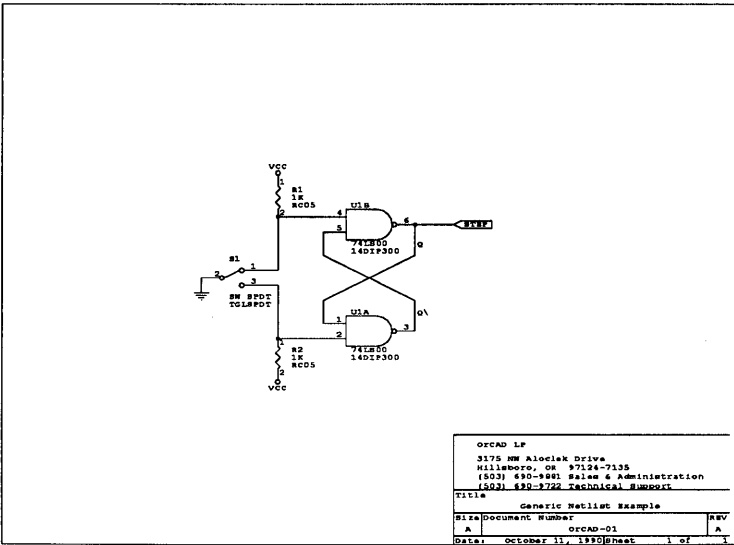

Figure 25-1. Plot created by Plot Schematic.



## Local Configuration

Select **Plot Schematic** from the **Schematic Design Tools** screen. A menu displays. Select **Local Configuration**.

Select **Configure PLOTALL**. A configuration screen appears (figure 25-2).

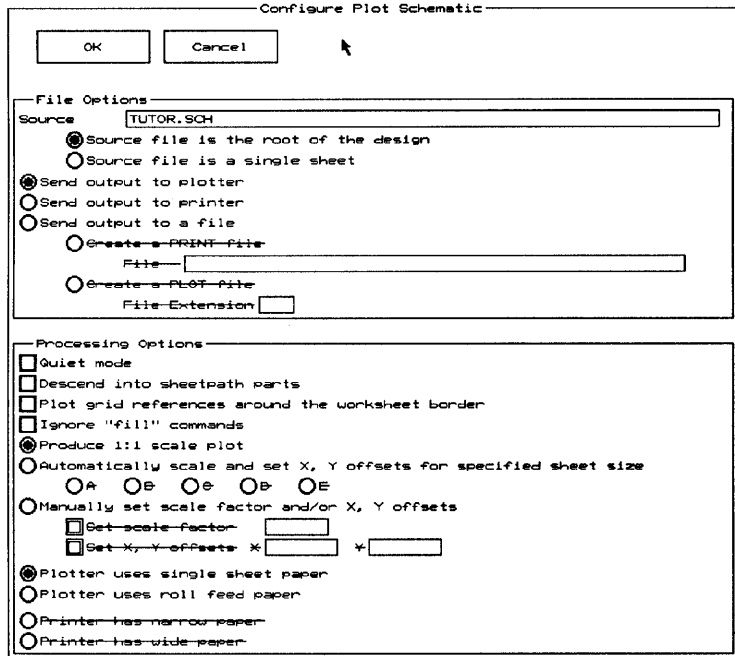

Figure 25-2. The Plot Schematic local configuration screen.

**File Options** File Options defines the source file and its type and the destination of the plot.

*Source* The Source can be the root sheet name of the design, or the filename of a single sheet, with any valid pathname.

△ **NOTE:** To have ESP configure the source filename for you, enter a question mark instead of the filename, followed by the file extension. For example, if you enter **? .SCH**, ESP changes the **?** to the name of the **Startup Design** (configured in the **Design Options** section of the **Configure ESP** screen) when you leave the local configuration screen.

After entering the source filename, select one of the following options:

- Source file is the root of the design  
Specifies that the source file is the root sheet name of a hierarchical or flat design. If the root sheet contains sheet symbols, then the design is hierarchical. If it contains a |Link, it is a flat design.
- Source file is a single sheet  
Specifies that the source file is a single worksheet and you want to process the single sheet only.

Select one of the following three options:

- Send output to plotter  
Use this option only if your sheet dimensions are 32 inches by 32 inches or less. Make sure you have configured the plotter driver on the **Configure Schematic Design Tools** screen to the plotter you want to use. See *Chapter 1: Configure Schematic Tools* for more information.
- Send output to printer  
Use this option to create a scaled print of your schematic. Make sure you have configured the printer driver on the **Configure Schematic Design Tools** screen to the printer you want to use. See *Chapter 1: Configure Schematic Tools* for more information.

△ **NOTE:** When plotting to a printer, make the pen width for buses small enough to make the lines thin. This makes the print neater and more readable. For example, if you have a printer with a resolution of 180 DPI, set the pen width to be:

$$\frac{\left(\frac{1}{180}\right)}{2} = 0.00277 \text{ inches}$$

Round the result up to 0.003 inches for best results. The same value is also used for the part body pen width and during FILL commands in the vector stream of the part definition.

- Send output to a file

Sends the **Plot Schematic** output to a file, rather than to a printer or plotter.

If the **Send output to a file** option is selected, you can select one of the following options:

- Create a PRINT file

File

- Create a PLOT file

File Extension

If either of these options is selected, the output is stored in a file (or files) containing the formatting codes required by your printer or plotter. Be sure you have configured the printer or plotter driver on the **Configure Schematic Design Tools** screen for the printer or plotter you want to use. See *Chapter 1: Configure Schematic Tools* for more information.

**Create a PRINT file** creates one large file containing print information for every sheet in the design, separated by page breaks. Enter a name for the file in the **File** entry box.

**Create a PLOT file** creates one file per worksheet in the design, with the filename extension you specify in the **File Extension** entry box appended to the sheet name—*except* when the option **Plotter uses roll feed paper** is selected. (This exception is described in the next paragraph.) You can then plot single sheets, or send the set of files to the plotter sequentially to plot the entire design.

When the option **Plotter uses roll feed paper** is selected, **Create a PLOT file**, like **Create a PRINT file**, produces one large file containing plot information separated by page breaks (roll feed commands).

**Processing Options** You may select any combination of the following options:

- Quiet mode  
Turns quiet mode on.
- Descend into sheetpath parts  
Causes **Plot Schematic** to descend into parts defined as sheetpath parts. Without this option selected, **Plot Schematic** treats the sheetpath itself as a part and does not plot the referenced sheets.
- Plot grid references around the worksheet border  
Tells **Plot Schematic** to include grid references in the plotted output.
- Ignore "fill" commands  
Specifies that parts with fills should not be filled in when plotted. It is a good idea to use this switch when you are reducing a plot or when you want to plot a draft version of your design quickly.

Select one of the following options:

- Produce 1:1 scale plot
- Automatically scale and set X, Y offsets for specified sheet size  
 A    B    C    D    E

Tells **Plot Schematic** to use the X,Y offsets of the specified sheet size, as configured in the template table. Select one of the following: A, B, C, D, or E.

- Manually set scale factor and/or X, Y offsets

- ▣ Set scale factor

Tells **Plot Schematic** to scale the plot by the scale factor you enter in **Set scale factor** entry box. The scale factor is a decimal number in the form: **###.###** . The default scale factor is 1.000. The allowed range is 0.10 to 10.000.

Table 25-1 shows the scale factors to use to plot worksheets on different sizes of plotter paper. The scale factors shrink or expand the image so the widest axis (horizontal or vertical) fits on the plotter paper. The narrow axis will have some blank area.

| Worksheet Size | Plotter Paper Size |       |       |       |       |
|----------------|--------------------|-------|-------|-------|-------|
|                | A                  | B     | C     | D     | E     |
| A              | 1.000              | 1.347 | 2.082 | 2.806 | 4.351 |
| B              | 0.638              | 1.000 | 1.329 | 2.083 | 2.776 |
| C              | 0.474              | 0.638 | 1.000 | 1.329 | 2.089 |
| D              | 0.301              | 0.472 | 0.627 | 1.000 | 1.311 |
| E              | 0.224              | 0.301 | 0.472 | 0.627 | 1.000 |

Table 25-1. *Plot Schematic scale factors.*

- △ **NOTE:** Table 25-1 assumes you are using the default **Template Table** values for Horizontal and Vertical paper dimensions. These values are set on the **Template Table** section of the **Configure Schematic Design Tools** screen. For more information, see Chapter 1: Configure Schematic Tools.

To scale the size of Plot Schematic's plot, find the scale factor in Table 25-1 corresponding to the worksheet size and plotter paper size you are using. Enter the number in the **Set scale factor**.

Scaling is also controlled by your plotter. Plotter scaling is typically controlled by the size of the paper used, rotation settings, and the other settings on the plotter.

If you change the size of the worksheets you are plotting (for example, plotting a C-size, then a B-size worksheet), *always RESET the plotter first* to return the plotter to a known state. If you have further scaling questions, see your plotter manual.

Set X, Y offsets X  Y

Specifies the plot's X and Y offset. Enter a decimal number, measured in inches from the center. The allowed range is -30.000 to 30.000. For example, when X is -3.600, it means the origin is 3.6 inches to the left of the plot's center.

Some plotters have their origin in the center rather than the lower left corner. If your schematic appears in the upper-right quadrant of the paper, set the X and Y offsets to negative values to move the origin to the lower left corner. Note X and Y are not affected by scaling.

Some plotter drivers (for example, HP.DRV) produce a divide error when you specify a D or E-size and do not specify an X,Y offset.

The plotter driver converts inches into plotter units and for large size plots the resulting number exceeds the 16-bit integer limit. Hence, large paper plotters compensate by having the origin in the center of the paper. You must adjust the origin back to the lower left corner with the X and Y offsets. Typically, the offsets are  $-\frac{1}{2}$  the paper dimension.

- △ **NOTE:** *The X and Y custom offsets are measurements after scaling is applied. For example, if you have a C-size worksheet you want to plot on B-size paper, you must use the **Use scale factor** option and specify 0.638 as the **Scale factor**. However, the X and Y values are B-size measurements.*

Select one of the following if **Send output to Plotter or Create a PLOT file** is selected:

- Plotter uses single sheet paper
- Plotter uses roll feed paper

**Tells Plot Schematic** that the plotter you are using has a roll feed. **Plot Schematic** inserts the commands necessary to roll the paper after each sheet. *Note: Not all plotters have roll-feed capability.*

Select one of the following if **Send output to Printer or Create a PRINT file** is selected to specify whether wide (13-inch) paper or narrow (8-inch) paper is used to plot to a printer:

- Printer has narrow paper
- Printer has wide paper



## *Print Schematic*

---

### Execution

**Print Schematic** prints schematic sheets. Use **Print Schematic** to print interim (working) copies of your design during the design process. Use **Plot Schematic** to plot the schematic when design work is complete.

**Print Schematic** prints one copy of each sheet that is referenced in a complex hierarchy, even if that sheet is referenced more than once.

There are two basic types of output devices that can be used with **Schematic Design Tools**: plotters and printers. These devices are categorized by the type of input they require.

If a device accepts *vector* commands, it is considered to be a plotter. A vector is a series of points with a specific function defined. For example, a line has a beginning point and an ending point. A circle has a center and a radius. The device needs to know what the vector information is but does not need every point along the vector.

If a device accepts *raster* commands, it is a printer. A raster is an array of dots. When you draw a line to a raster device, you must specify each and every dot.



**Running Print Schematic**

Select **Print Schematic** from the **Schematic Design Tools** screen. Select **Execute** from the menu that displays.

While **Print Schematic** Runs, messages display in the monitor box at the bottom of the screen. When the report is complete, the **Schematic Design Tools** screen appears.

**Sample output**

Figure 26-1 shows a sample printout created by **Print Schematic**.

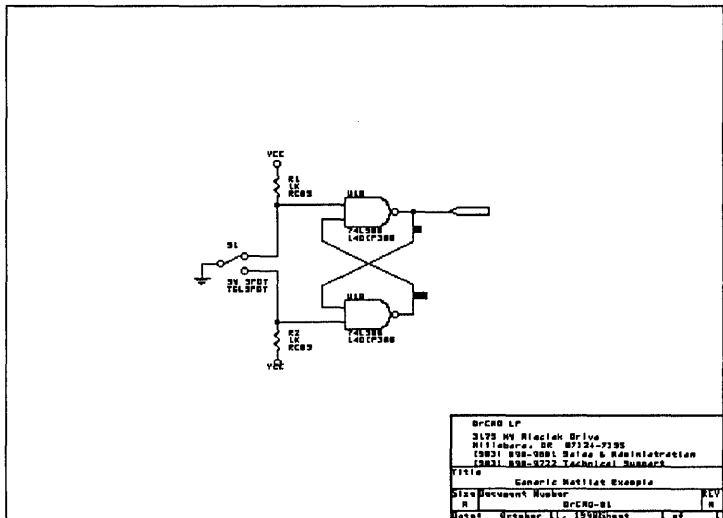

Figure 26-1. Output created by **Print Schematic**.

---

## Local Configuration

With the Schematic Design Tools screen displayed, select **Print Schematic**. Select **Local Configuration** from the menu that displays.

Select **Configure PRINTALL**. A configuration screen appears (figure 26-2).

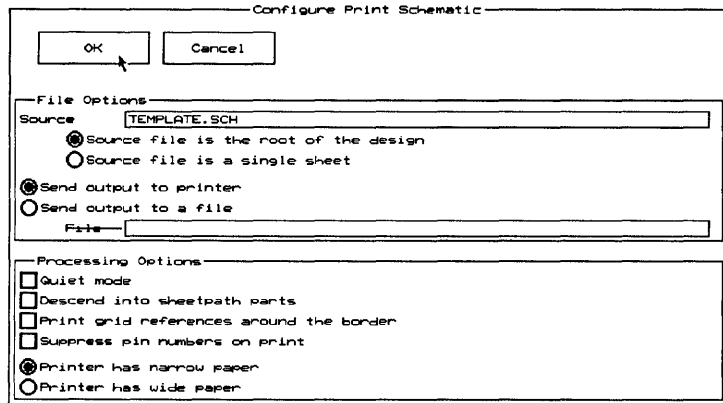

Figure 26-2. Print Schematic's local configuration screen.

**File Options**     **File Options** defines the source file and type and the destination of the print.

*Source*     The **Source** can be the root sheet name of the design, or the filename of a single sheet. It may have any valid pathname.

△ ***NOTE:** If you want ESP to configure the filename of the source for you, enter a question mark instead of the filename, followed by the file extension. For example, if you enter ?.SCH, ESP changes the ? to the name of the **Startup Design** configured in the **Design Options** section of the **Configure ESP** screen when you leave the local configuration screen.*

After entering the source filename, select one of the following options:

- Source file is the root of the design  
Specifies that the source file is the root sheet name of a hierarchical or flat design. If the root sheet contains sheet symbols, then the design is hierarchical. If it contains a |Link, it is a flat design.
- Source file is a single sheet  
Specifies that the source file is a single worksheet and you want to process the single sheet only.

Select one of the following options:

- Send output to printer
- Send output to a file

If you select **Send output to a file**, enter the path and filename of the output file in the **File** entry box.

**Processing Options**    You may select any combination of the following options:

- Quiet mode  
Turns quiet mode on.
- Descend into sheetpath parts  
Tells **Print Schematic** to descend into parts defined as sheetpath parts. Without this option selected, **Print Schematic** treats the sheetpath itself as a part and does not print the referenced sheets.
- Print grid references around the border  
Tells **Print Schematic** to include grid references in the plotted output.
- Suppress pin numbers on print  
Tells **Print Schematic** to print the schematic without pin numbers.

Select either of the following options:

- Printer has narrow paper
- Printer has wide paper

Specifies whether wide (13-inch) paper or narrow (8-inch) paper is used to plot to a printer.





## *Create Bill of Materials*

---

### Execution

The **Create Bill of Materials** reporter creates a summary list of all parts used in a design. **Create Bill of Materials** scans a design or only a single sheet.

Optionally, special information specific to your application may be added in a text file called an "include file." If this special information is included, **Create Bill of Materials** lists the parts found in the order in which they appear in the include file. Any parts not in the include file are placed at the end of the report.

### Running Create Bill of Materials

With the **Schematic Design Tools** screen displayed, select **Create Bill of Materials**. Select **Execute** from the menu that displays.

While **Create Bill of Materials** runs, messages display in the monitor box at the bottom of the screen. When the report is complete, the **Schematic Design Tools** screen appears.

**Sample output**    **Figure 27-1 shows a sample parts list created by Create Bill of Materials.**

| Generic Netlist Example |                  | Revised: October 11, 1990 |         |
|-------------------------|------------------|---------------------------|---------|
| OrCAD-01                |                  | Revision: A               |         |
| Bill Of Materials       | October 15, 1990 | 8:38:46                   | Page 1  |
| Part                    | Used             | Reference                 |         |
| 1                       | 2                | R2,R1                     | 1K      |
| 2                       | 1                | S1                        | SW SPDT |
| 3                       | 1                | U1                        | 74LS00  |

*Figure 27-1. Bill of Materials created by Create Bill of Materials.*

**Key fields** **Create Bill of Materials** has one key field. It is shown in the **Key Fields** section of the **Configure Schematic Design Tools** screen as follows:

|                          |                      |
|--------------------------|----------------------|
| Create Bill of Materials |                      |
| Part Value Combine       | <input type="text"/> |
| Include File Combine     | <input type="text"/> |

**Create Bill of Materials** uses the **Part Value Combine** key field to combine the part value and part fields together to become the value used in the summary list. For parts to have the same value in the **Create Bill of Materials** report, they must have the same values in the key field. If you do not specify a key field, the **Create Bill of Materials** value is the part's value.

The **Include File Combine** is used to build a lookup string to match in the Include File. As with the **Part Value Combine**, if this key field is not specified, the **Part Value** is assumed to be the match string.

For more information about key fields, see *Chapter 1: Configure Schematic Tools*.



## Local Configuration

With the Schematic Design Tools screen displayed, select **Create Bill of Materials**. Select **Local Configuration** from the menu that displays.

Select **Configure PARTLIST**. A configuration screen appears (figure 27-2).

Configure Create Bill of Materials

OK Cancel

File Options

Source: TEMPLATE.SCH

Source file is the root of the design  
 Source file is a single sheet

Destination: TEMPLATE.BOM

Merge an include file with report

Include:

Processing Options

Quiet mode  
 Descend into sheetpath parts  
 Place each part entry on a separate line  
 Verbose report  
 Insert a header for each page  
 Do not insert a header for each page  
Report is  single-spaced  double-spaced  
 Report unused match strings in include file  
 Ignore warnings

Figure 27-2. Local configuration screen for *Create Bill of Materials*.

### File Options

**File Options** defines the source file and its type. It also defines the destination file and whether to merge an include file with the partlist.

### Source

The **Source** can be the root sheet name of the design, or the filename of a single sheet. It may have any valid pathname.



**NOTE:** If you want ESP to configure the filename of the source for you, enter a question mark instead of the filename, followed by the file extension. For example, if you enter `? .SCH`, ESP changes the `?` to the name of the **Startup Design** configured in the **Design Options** section of the **Configure ESP** screen when you leave the local configuration screen.

After entering the source filename, select one of the following:

- Source file is the root of the design  
Specifies that the source file is the root sheet name of a hierarchical or flat design. If the root sheet contains sheet symbols, then the design is hierarchical. If it contains a |Link, it is a flat design.
- Source file is a single sheet  
Specifies that the source file is a single worksheet and you want to process the single sheet only.

*Destination*     The **Destination** is any valid system pathname, and is where the output of the report is to be placed. If a destination is not specified, the output of **Create Bill of Materials** displays in the monitor box at the bottom of the screen.

*Include*      Merge an include file with report

The **Include** is the path and filename of a text file containing information to be merged in the Bill of Materials. The format of this file is discussed below.

After you select this option, the **Include** entry box changes from dim to highlighted. Enter the name of the include file in the **Include** entry box.

*Include file format*

The include file is a text file in which you place additional part information. This part information is included in the **Create Bill of Materials** summary list. A sample include file is shown in figure 27-3.

The first line of the file is a header line. The line begins with a pair of single quotes with no characters or spaces between them. The rest of the line contains the header information you want to include.

The remainder of the file contains separate lines for each part needing additional information. Each line must begin with the part name as it appears in your worksheet. The name must be enclosed within single quotes (such as '74LS00'). Following the part name (on the same line), place the information that you want included for that part (for example, "TTL Quad Two Input NAND Gate 10004040000").

For both types of lines, header and part, the line will be aligned with the first non-space character of the information portion of the line. When **Create Bill of Materials** has finished scanning the sheets, it then scans the include file to include the rest of the line after any part name that matches.

| ' '       | DESCRIPTION                  | Part Order Code |
|-----------|------------------------------|-----------------|
| '1K'      | Resistor 1/4 Watt 5%         | 10000111003     |
| '4.7K'    | Resistor 1/4 Watt 5%         | 10000114703     |
| '22K'     | Resistor 1/4 Watt 5%         | 10000112204     |
| '1uf'     | Capacitor Ceramic Disk       | 10000211006     |
| '.1uf'    | Capacitor Ceramic Disk       | 10000211007     |
| '.01uf'   | Capacitor Ceramic Disk       | 10000211008     |
| '.001uf'  | Capacitor Ceramic Disk       | 10000211009     |
| '7400'    | TTL Quad Two Input NAND Gate | 10001040000     |
| '74LS00'  | TTL Quad Two Input NAND Gate | 10002040000     |
| '74S00'   | TTL Quad Two Input NAND Gate | 10003040000     |
| '74ALS00' | TTL Quad Two Input NAND Gate | 10004040000     |
| '74AS00'  | TTL Quad Two Input NAND Gate | 10005040000     |
| '7402'    | TTL Quad Two Input NAND Gate | 10001040002     |
| '74LS02'  | TTL Quad Two Input NAND Gate | 10002040002     |
| '74S02'   | TTL Quad Two Input NAND Gate | 10003040002     |
| '74ALS02' | TTL Quad Two Input NAND Gate | 10004040002     |
| '74AS02'  | TTL Quad Two Input NAND Gate | 10005040002     |

Figure 27-3. Include file format.

**Processing Options**

You may select any combination of the following options:

- Quiet mode  
Turns quiet mode on.
- Descend into sheetpath parts  
Tells **Create Bill of Materials** to descend into any parts defined as sheetpath parts. Without this option selected, **Create Bill of Materials** treats the sheetpath itself as a part to be listed and does not list the parts within a sheetpath.
- Place each part entry on a separate line  
Tells **Create Bill of Materials** to put each part entry on a separate line in the summary.
- Verbose report  
Tells **Create Bill of Materials** to produce a more detailed report. This report includes the title block information.

Select either of the following options:

- Insert a header for each page
- Do not insert a header for each page

These options specify whether or not to insert a header on each page. The header includes information such as the title of the design, the date, the document number, the revision code, the report name, the page number (if you select **Insert a header for each page**), and the time the report is created.

Select either of the following options:

- Report is
- single-spaced
  - double-spaced

These options specify whether the report is single- or double-spaced.

If desired, select either of these options:

- Report un-used match strings in an include file

Tells **Create Bill of Materials** to keep track of which strings in an include file don't have a corresponding match string in the design. This report can be used to find match strings in an include file that were accidentally entered duplicated.

- Ignore warnings

Causes **Create Bill of Materials** to continue running when it encounters warnings, instead of halting in the middle of execution.



## *Show Design Structure*

---

### Execution

**Show Design Structure** scans the schematics in a design to display the sheet names and their associated worksheet filenames.

### Running Show Design Structure

With the **Schematic Design Tools** screen displayed, select **Show Design Structure**. Select **Execute** from the menu that displays.

While **Show Design Structure** runs, messages display in the monitor box at the bottom of the screen. When the report is complete, the **Schematic Design Tools** screen appears.

### Sample output

Figure 28-1 shows a sample report created by **Show Design Structure**.

```
<<<root>>>
[EX6.SCH]   October 11, 1990
  halfadd_A
  [ex6b.sch]   October 11, 1990
  halfadd_B
  [ex6b.sch]   October 11, 1990
```

*Figure 28-1. Report created by Show Design Structure.*

## Local Configuration

With the Schematic Design Tools screen displayed, select **Show Design Structure**. Select **Local Configuration** from the menu that displays.

Select **Configure TREELIST**. A configuration screen appears (figure 28-2).

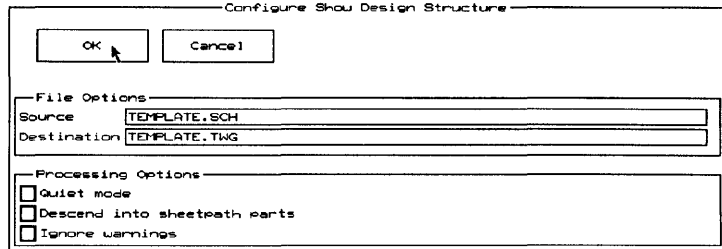

Figure 28-2. Show Design Structure's local configuration screen.

- File Options**    **File Options** defines the source file and its destination file.
- Source*    The **Source** is the name of the root sheet of the design.
- △    *NOTE: To have ESP configure the source filename for you, enter a question mark instead of the filename, followed by the file extension. For example, if you enter **? .SCH**, ESP changes the ? to the name of the **Startup Design** (configured in the **Design Options** section of the **Configure ESP** screen) when you leave the local configuration screen.*
- Destination*    A pathname where the output of **Show Design Structure** is to be placed. If a path is not specified, the output displays in the monitor box at the bottom of the screen.
- Processing Options**    You may select any combination of the following options:
- Quiet mode  
Turns quiet mode on.
  - Descend into sheetpath parts  
Tells **Show Design Structure** to descend into any sheetpath parts. Without this option selected, **Show Design Structure** treats the sheetpath itself as a part and does not descend into the sheetpath.
  - Ignore warnings  
Causes **Show Design Structure** to continue running when it encounters warnings, instead of halting in the middle of execution.





# PART VI: TRANSFERS

---

**Schematic Design Tools** includes Transfer tools that manage the steps needed to move design information from one tool set to another. Transfers update the database then change from **Schematic Design Tools** to other OrCAD tool set screens.

Part VI describes Transfer tools and provides instructions for their use.

*Chapter 29:* *To PLD* describes the transfer to the **Programmable Logic Design Tools** screen.

*Chapter 30:* *To Digital Simulation* describes the transfer to the **Digital Simulation Tools** screen.

*Chapter 31:* *To Layout* describes the transfer to the **PC Layout Tools** screen.

*Chapter 32:* *To Main* describes the transfer to the main ESP design environment screen.





## To PLD

---

### About To PLD

The To PLD transfer consists of three processes that update the database so that the design may be viewed by the **Programmable Logic Design Tools**. These processes are:

- ❖ **FLDSTUFF (Update Field Contents)** loads information you define into the fields of parts on a specified schematic.

FLDSTUFF constructs a string from the key field designators for a specified field. Then, if that string equals a match field in a designated update file, it replaces the specified field with the update value.

For more information about this process, see *Chapter 13: Update Field Contents*.

- ❖ **ANNOTATE (Annotate Schematic)** scans a design and automatically updates the reference designators of all parts in the worksheet.

ANNOTATE updates reference designators in the order they were placed in the worksheet. When the worksheet is annotated, all parts may be assigned a new reference designator, including any manually edited parts. To selectively change reference designators and leave others unmodified, use **Draft**.

For more information about this process, see *Chapter 6: Annotate Schematic*.

- ❖ **EXTRACT** (the Extract PLD processor on the **Program-mable Logic Design Tools** screen) extracts PLD source code from a schematic for use with **Programmable Logic Design Tools**. The program reads a .SCH file and produces one or more .PLD files, adding pin information and other coding in the process.

For more information about this process, see *Chapter 8: Using the Extract PLD processor in the Programmable Logic Design Tools User's Guide*.

---

## Execution

**To PLD** reads the schematic database and updates the PLD source files for all devices found in the design. The design may be a complex or simple hierarchy, or a flat design.

- △ **NOTE:** *If the source code for the PLD logic is a schematic, it should be created and edited in the **Programmable Logic Design Tools** area with the **Edit Schematic Logic** button. While technically the schematic for the internals of the PLD is part of the design, it is isolated by the fact that it represents the internal logic of the device. The schematics for the board, on the other hand, represent the external view of the logic for the design.*

## Running To PLD

With the **Schematic Design Tools** screen displayed, select **To PLD**. Select **Execute** from the menu that displays.

When the transfer process is complete, the **Programmable Logic Design Tools** screen displays (figure 29-1).

The **Edit Schematic Logic** and **Compile Schematic Logic** buttons are preconfigured at OrCAD with the correct libraries for logic development and the correct settings for the PLD compiler.

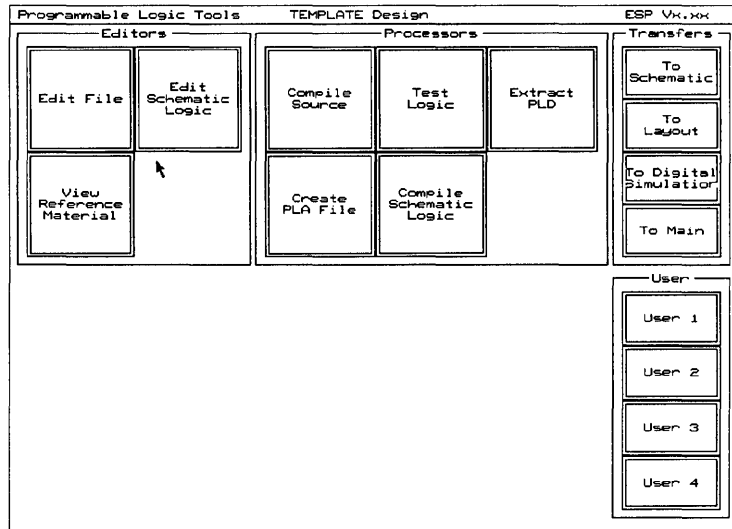

Figure 29-1. Programmable Logic Design Tools screen.

## Local Configuration of To PLD

Since FLDSTUFF, ANNOTATE, and EXTRACT are each configured individually, **To PLD** has three configuration screens. To configure **To PLD**, select **To PLD**. Select **Local Configuration** from the menu that displays.

The menu shown at right displays. Use this menu to choose which **To PLD** process to configure or to turn a process on or off. When you run **To PLD**, only the processes that are turned on run. In most cases, you will have EXTRACT turned on and the other processes turned off.

```
Configure FLDSTUFF
Configure ANNOTATE
Configure EXTRACT
FLDSTUFF off
ANNOTATE off
EXTRACT on
```

To turn a process on or off, choose the desired process from the menu. For example, to turn FLDSTUFF on, select **FLDSTUFF off** from the menu. **Schematic Design Tools** displays:

```
Select the new status of the executable item
```

A menu with the options **on** and **off** displays. Select **on** to turn the process on.

## Local Configuration of FLDSTUFF

With the Schematic Design Tools screen displayed, select **To PLD**. Select **Local Configuration** from the menu that displays, and then select **Configure FLDSTUFF**. A configuration screen displays (figure 29-2).

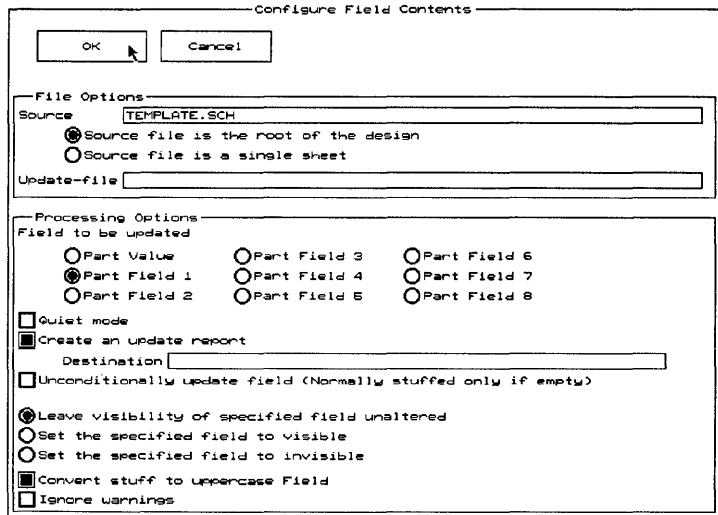

Figure 29-2. FLDSTUFF's local configuration screen.

### File Options

**File Options** defines the source file and its type. It also defines the update file.

#### Source

The **Source** is the root sheet and filename of the design or the filename of a single sheet. It may have any valid pathname. After entering the source filename, select one of the following:

- Source file is the root of the design

Specifies that the source file is the root sheet filename of a hierarchical or flat design.

- Source file is a single sheet

Specifies that the source file is a single worksheet and you want to process the single sheet only.

#### Update-file

The **Update-file** is a text file that you create. The file format is described in *Chapter 13: Update Field Contents*.

**Processing Options** Select one of the following options to define which field is to be updated:

- Part Value                       Part Field 5  
 Part Field 1                     Part Field 6  
 Part Field 2                     Part Field 7  
 Part Field 3                     Part Field 8  
 Part Field 4

The field parameter selected above also identifies a key field designator. There are nine key field designators, one for the part's value, and one for each of the eight part fields. They are found on the **Configure Schematic Design Tools** screen as shown in figure 29-3.

| Update Field Contents |                      |
|-----------------------|----------------------|
| Combine for Value     | <input type="text"/> |
| Combine for Field 1   | <input type="text"/> |
| Combine for Field 2   | <input type="text"/> |
| Combine for Field 3   | <input type="text"/> |
| Combine for Field 4   | <input type="text"/> |
| Combine for Field 5   | <input type="text"/> |
| Combine for Field 6   | <input type="text"/> |
| Combine for Field 7   | <input type="text"/> |
| Combine for Field 8   | <input type="text"/> |

Figure 29-3. Key field designators for FLDSTUFF.

FLDSTUFF constructs a string from the key field designator set up for the field parameter selected. For example, if you select "Part Field 3" and the **Update Field Contents Combine for Field 3** is V 2, then **Update Field Contents** constructs a string consisting of the part's value, a space, and the contents of 2nd Part Field.

FLDSTUFF then tries to match that string with the match fields listed in the update file. Each match field has a corresponding update field. If a match occurs, **Update Field Contents** replaces the contents of the field parameter (selected above) with the corresponding update field.

For additional information about key fields, see the *Schematic Design Tools User's Guide*.



The key fields shown are shared between this process and the **Update Field Contents** processor. For more information on the key fields and other operating characteristics, see *Chapter 13: Update Field Contents*.

Select any combination of the following options:

- Quiet mode  
Turns quiet mode on.
- Create an update report  
Creates a report listing all the parts on each sheet and whether a field was updated for each part. If this option is selected, the **Destination** entry box is used to specify where the report is written.
- Unconditionally update field (Normally stuffed only if empty)  
Unconditionally changes the specified field. By default a field is only updated if it is empty. That is, fields with values already in them are not updated.

Select one of the following options to indicate whether you want the updated field to be visible, invisible, or to stay in its current state:

- Leave visibility of specified field unaltered
- Set specified field to visible
- Set specified field to invisible

You may select either or both of these options:

- Convert stuff to uppercase Field  
Converts the match strings in the update file to uppercase as they are inserted into the fields on the schematic.
- Ignore warnings  
Causes FLDSTUFF to continue running when it encounters warnings, instead of halting in the middle of execution.

## Local Configuration of ANNOTATE

With the **Schematic Design Tools** screen displayed, select **To PLD**. Select **Local Configuration** from the menu that displays, and then select **Configure ANNOTATE**. A configuration screen appears (figure 29-4).

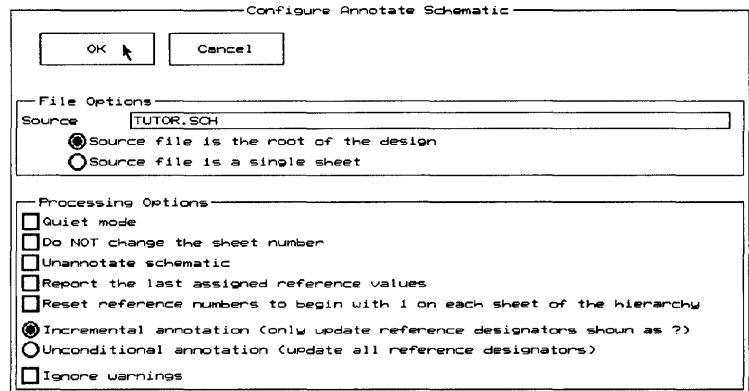

Figure 29-4. ANNOTATE's local configuration screen.

**File Options** **File Options** defines the source file and its type.

*Source* The **Source** is the root sheet filename of the design or the filename of a single sheet. It may have any valid pathname. After entering the source filename, select one of the following:

- Source file is the root of the design  
Specifies that the source file is the root sheet filename of a hierarchical or flat design. If the root sheet contains sheet symbols, then the design is hierarchical. If it contains a |Link, it is a flat design.
- Source file is a single sheet  
Specifies that the source file is a single worksheet and you want to process the single sheet only.

**Processing Options** You may select any combination of the following options:

- Quiet mode  
Turns quiet mode on.
- Do NOT change the sheet number  
Causes the sheet number set in the title block to remain unchanged. If this option is not selected, ANNOTATE renumbers all of the schematics in the design.
- Unannotate schematic  
Resets all of the reference designators in the design. When parts were first placed, the reference designator had a numeric component of "?". This option resets all numbers to "?".
- Report the last assigned reference values  
Tells ANNOTATE to report the last reference designator assigned to a design, after it is done annotating. The report is placed in a file with the same name as the source ending with the extension .END.
- Reset reference numbers to begin with 1 on each sheet of the hierarchy  
Restarts all reference designators used at 1 for each sheet of the design instead of only on the first sheet. This option is used when annotating a complex hierarchy. If you are using OrCAD's **Digital Simulation Tools** and your design is a complex hierarchy, this option is recommended.

Select one of the following:

- Incremental annotation (only update reference designators shown as ?)

Updates only the reference designators that have a "?". When new parts are placed on a sheet, the reference is not assigned a numeric value, but rather is given the unassigned designation of "?". If you do not wish to renumber all reference designators, including all previously set references, this option should be used.

- Unconditional annotation (update all reference designators)

Updates all reference designators in the order in which they are placed in the worksheet. All references are updated, even those that may have been assigned previously.

If desired, select this option:

- Ignore warnings

Causes ANNOTATE to continue running when it encounters warnings, instead of halting in the middle of execution.

## Local Configuration of EXTRACT

With the **Schematic Design Tools** screen displayed, select **To PLD**. Select **Local Configuration** from the menu that displays, and then select **Configure EXTRACT**. A configuration screen appears (figure 29-5).

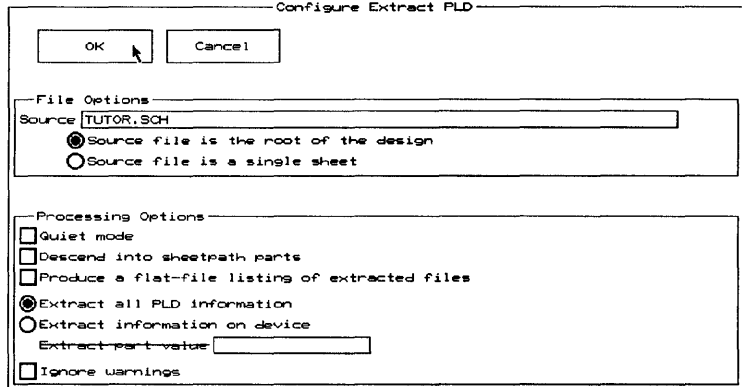

Figure 29-5. EXTRACT's local configuration screen.

### File Options

**File Options** defines name and type of the schematic from which to extract the PLD information.

#### Source

The source file is the root sheet filename of the design or the filename of a single sheet. It may have any valid pathname. After entering the source filename, select one of the following:

- Source file is the root of the design

Specifies that the source file is the root sheet name of a hierarchical or flat design. If the root sheet contains sheet symbols, then the design is hierarchical. If it contains a |Link, it is a flat design.

- Source file is a single sheet

Specifies that the source file is a single worksheet and you want to process the single sheet only.

## Processing Options

You may select either or both of the following options:

- Quiet mode  
Turns quiet mode on.
- Descend into sheet path parts  
Tells EXTRACT to descend into parts defined as sheetpath parts. That is, it treats a sheetpath part as a sheet. This option, while designed for complex hierarchies, may be used in simple hierarchies. It is not recommended to be used except for FPGA, ASIC, or other designs that require a complex hierarchy.
- Produce a flat-file listing of extracted files  
Tells EXTRACT to produce a text file listing all the PLD files in the design.

Select one of the following:

- Extract all PLD information  
Causes EXTRACT to extract all PLD source code from the schematic.
- Extract information on device  
Causes EXTRACT to extract the PLD source code for one specific device. Selecting this option makes the **Extract part value** entry box active. Specify the device to extract by entering its part value (the value that appears on the schematic for the particular device) in the entry box.

You may select this option:

- Ignore warnings  
Causes EXTRACT to continue running when it encounters warnings, instead of halting in the middle of execution.

**About EXTRACT** The names and number of output files EXTRACT creates depend on specially-formatted text (also called *source code*) that you place in your worksheet. This source code specifies information about a part in the **Programmable Logic Design Tools** language.

*Key fields* EXTRACT uses two key fields. They are shown on the **Configure Schematic Design Tools** screen as:

```
Extract PLD
  PLD Part Combine 
  PLD Type Combine 
```

When EXTRACT creates a .PLD file, it uses these key fields to fill in the Part: and Type: data fields. The **PLD Part Combine** data is enclosed in quotation marks and placed after the word "Part:". The **PLD Type Combine** data is enclosed in quotation marks and placed after the word "Type:". Figures 29-6 and 29-7 show an example.

More information about key fields for EXTRACT is found in *Chapter 1: Configure Schematic Tools*.

*Unified documentation* The source code for a PLD is compiled separately from the schematic. To keep all documentation about a design together, though, it is a good idea to place the code on the schematic. It is also easier to write the source code for a PLD as part of the schematic, because EXTRACT will create pin definitions and title information for you.

In a schematic, PLD source code is placed on the same sheet as the schematic symbol for the programmable device. The source code can be anywhere on the sheet.

*Make a custom symbol* Unlike non-programmable devices that have the same behavior every time they are used in a design, the behavior of programmable devices varies as the internal logical configuration changes. So, to represent a PLD in a design, you first need to create an appropriate symbol for it. The schematic library MEMORY.LIB contains generalized symbols for programmable devices, with values like 16R6 and pin names like I1, I2, and O1.

To customize a part to fit your application, use **Edit Library** to modify the pin names and device names to be the values for this specific application. When you create a custom part, it is always best to store it in your own custom library. That way, if you receive new libraries from OrCAD, you can replace your old libraries without fear of erasing your custom parts.

*Defining the PLD's  
internal logic*

Using OrCAD's **Programmable Logic Design Tools**, you can define logic in several different ways. You can use Boolean equations, indexed equations, numerical maps, state machine procedures, truth tables, streams, or schematics. See the *Programmable Logic Design Tools Reference Guide* for more information.

The logic definition for the PLD consists of a series of text objects placed on the schematic. The text may be placed line-by-line with **Draft's PLACE Text** command or may be created using **Edit File** and placed on the schematic using the **BLOCK ASCII Import** command.

PLD logic definitions must begin with a key statement:

|PLD *part*

Use **Draft's PLACE Text** command to add the statement to the schematic.

This is done by moving the pointer to an open area on your schematic. Select **PLACE**, then **Text**. Type the pipe or vertical bar symbol ( | ) followed by **PLD** and the name of the custom part:

|PLD *name*

If more than one PLD is defined on this schematic, create a |PLD key statement for each one. **EXTRACT** creates a .PLD file for each part specified in the schematic. Each .PLD file contains the source code associated with its corresponding part.



For example, suppose you have included the source code for two different PLDs (A and B) in your schematic. When you run EXTRACT, two files are created: A.PLD and B.PLD. If either file already exists, EXTRACT renames the original file with a .BAK extension before creating the new .PLD file. For example, if A.PLD already exists, it is renamed A.BAK before the new A.PLD is created.

You can add comments, too. Just enter each line individually and place it in the schematic so that the first character of the line is in the same column as the pipe symbol of the device name line (see figure 29-7). Comment lines (those lines that do not start with a pipe character) are ignored by the **Programmable Logic Design Tools** compiler.

*Select a device*

Selecting a device is a decision based primarily on two factors: design complexity and cost. You base your decision on the number of inputs and outputs needed, how complex the logic is that the device needs to handle, and how much the device costs. Just exactly *when*, in the design process, you have to choose a device, is a matter for you, the designer, to determine. For example, you may want to define the logic completely, test it to be sure it performs as you expect, and then pick a device that accommodates the logic. On the other hand, you may have a device in mind before you begin designing the logic—one that for cost or availability reasons is your definite choice.

*Record part type and value on the schematic*

After you have selected a device, record your choice on the schematic in the device symbol's part fields. Typically, the **1st Part Field** is used to specify the PLD type (22V10, for example) and the **2nd Part Field** is used to specify the manufacturer's exact part number—but you can use any pair of the eight part fields to hold this information. EXTRACT uses this information to create a PLD header file.

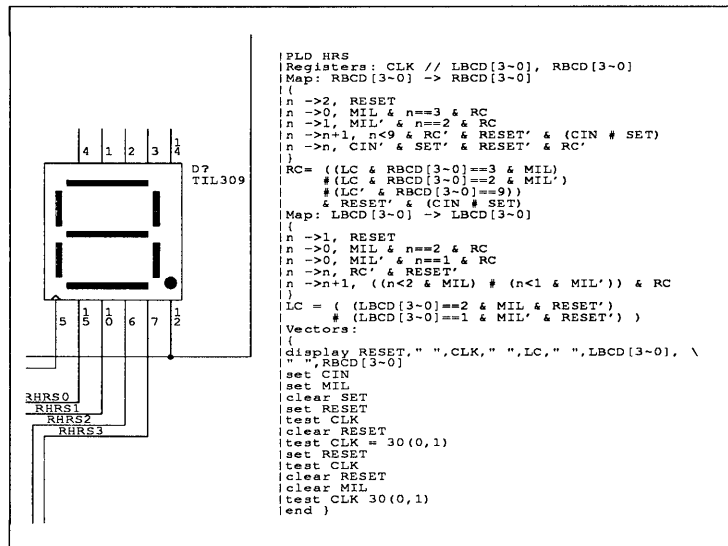

Figure 29-6. Programmable logic device.

When you run EXTRACT on the schematic containing the part, it creates a file called HRS.PLD. The contents of HRS.PLD are shown in figure 29-7. In the HRS.PLD output, the PLD Type Combine key field (1st Part Field) is shown in *bold italics*, and the PLD Part Combine key field (2nd Part Field) is shown in **bold**.

```

| "HRS"  1:CLK,
|        2:-,
|        3:-,
|        4:-,
|        5:-,
|        6:-,
|        7:-,
|        8:-,
|        9:MIL,
|       10:SET,
|       11:CIN,
|       13:RESET,
|       23:LC,
|       22:LBCD3,
|       21:LBCD2,
|       20:LBCD1,
|       19:LBCD0,
|       18:RC,
|       17:RBCD3,
|       16:RBCD2,
|       15:RBCD1,
|       14:RBCD0
|
|Value:   "HRS"
|Type:    "22V10"
|Part:    "PALC22V10-35"
|Library: "EXAMPLE.LIB"
|
|Title:   "Example schematic"
|Title:   " November 5, 1990"
|
|Registers: CLK // LBCD[3~0], RBCD[3~0]
|Map: RBCD[3~0] -> RBCD[3~0]
|{
|n ->2, RESET
|n ->0, MIL & n==3 & RC
|n ->1, MIL' & n==2 & RC
|n ->n+1, n<9 & RC' & RESET' & (CIN # SET)
|n ->n, CIN' & SET' & RESET' & RC'
|}
|RC= ((LC & RBCD[3~0]==3 & MIL)
|      #(LC & RBCD[3~0]==2 & MIL')
|      #(LC' & RBCD[3~0]==9))
|      & RESET' & (CIN # SET)
|Map: LBCD[3~0] -> LBCD[3~0]
|{
|n ->1, RESET

```

Figure 29-7. Sample EXTRACT output (continued on next page).

```
|n ->0, MIL & n==2 & RC
|n ->0, MIL' & n==1 & RC
|n ->n, RC' & RESET'
|n ->n+1, ((n<2 & MIL) # (n<1 & MIL')) & RC
|}
|LC = ( (LBCD[3~0]==2 & MIL & RESET')
|      # (LBCD[3~0]==1 & MIL' & RESET') )
|Vectors:
|{
|display RESET," ",CLK," ",LC," ",LBCD[3~0], \
|" ",RBCD[3~0]
|set CIN
|set MIL
|clear SET
|set RESET
|test CLK
|clear RESET
|test CLK = 30(0,1)
|set RESET
|test CLK
|clear RESET
|clear MIL
|test CLK 30(0,1)
|end }
```

Figure 29-7. Sample EXTRACT output (continued from previous page).





## *To Digital Simulation*

### **About To Digital Simulation**

The To Digital Simulation transfer consists of four processes that update the connectivity database and simulation directives for the design. These processes are:

- ❖ **ANNOTATE (Annotate Schematic)** scans a design and automatically updates the reference designators of all parts in the worksheet.

ANNOTATE updates reference designators in the order they were placed in the worksheet. When annotating the worksheet, you may assign all parts a new reference designator, including any manually edited parts. To selectively change reference designators and leave others unmodified, use **Draft**.

For more information about this process, see *Chapter 6: Annotate Schematic*.

- ❖ **INET (Create Netlist)** creates or updates the incremental connectivity database for the design. INET is an incremental processor. It updates the database only for those worksheets that have changed.
- ❖ **IBUILD (Build Simulation Specification File)** extracts the trace, stimulus, and test vector information from the connectivity database, creating text trace (.ATR) and stimulus (.AST) files.
- ❖ **ASCTOVST (Compile Simulation Specification File)** reads the text file IBUILD creates, converts it to binary format, and copies the results to a breakpoint, stimulus, or trace file. ASCTOVST displays twice on the configuration screen, so you can convert both the stimulus and trace files when transferring to **Digital Simulation Tools**.

## Execution

**To Digital Simulation** updates the schematic database, the connectivity database, and the simulation directives. The design may be a complex or simple hierarchy, or a flat design.

### Running To Digital Simulation

With the **Schematic Design Tools** screen displayed, select **To Digital Simulation**. Select **Execute** from the menu that displays.

During the transfer process, a monitor box displays at the bottom of the screen where messages report the progress of transfer tasks.

When the transfer process is complete, the **Digital Simulation Tools** screen displays (figure 30-1).

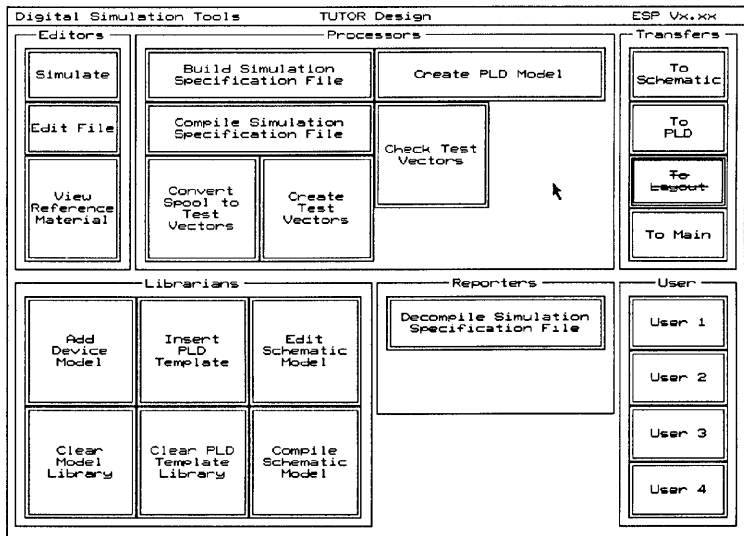

Figure 30-1. Digital Simulation Tools screen.

## Local Configuration of To Digital Simulation

Since you can configure ANNOTATE, INET, IBUILD and each ASCTOVST individually, **To Digital Simulation** has five configuration screens. To configure **To Digital Simulation**, select **To Digital Simulation**. Select **Local Configuration** from the menu that displays.

The menu shown at right displays. Use this menu to choose which **To Digital Simulation** process to configure or to turn a process on or off. When you select **To Digital Simulation**, only the processes that are turned on will run.

For most cases, you will have INET turned on and the other processes turned off. If you are making extensive changes to trace, stimulus, or vector objects in the schematic, turn the IBUILD and ASCTOVST processes on.

To turn a process on or off, choose the desired process from the menu. For example, to turn ANNOTATE on, select **ANNOTATE off** from the menu. **Schematic Design Tools** displays:

|                    |
|--------------------|
| Configure ANNOTATE |
| Configure INET     |
| Configure IBUILD   |
| Configure ASCTOVST |
| Configure ASCTOVST |
| ANNOTATE off       |
| INET on            |
| IBUILD off         |
| ASCTOVST off       |
| ASCTOVST off       |

Select the new status of the executable item

A menu with the options **on** and **off** displays. Select **on** to turn the process on.



## Local Configuration of ANNOTATE

With the Schematic Design Tools screen displayed, select **To Digital Simulation**. Select **Local Configuration** from the menu that displays, and then select **Configure ANNOTATE**. A configuration screen appears (figure 30-2).

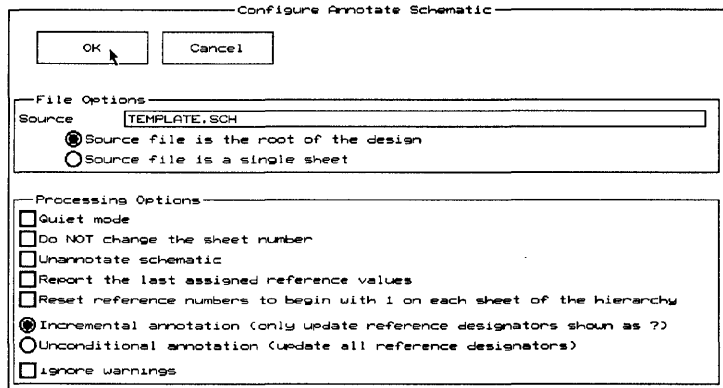

Figure 30-2. ANNOTATE's local configuration screen.

**File Options** File Options defines the source file and its type.

*Source* The Source is the root of the design of the filename of a single sheet. It may have any valid pathname.

After entering the source filename, select one of the following:

- Source file is the root of the design  
Specifies that the source file is the root sheet filename of a hierarchical or flat design. If the root sheet contains sheet symbols, then the design is hierarchical. If it contains a |Link, it is a flat design.
- Source file is a single sheet  
Specifies that the source file is a single worksheet and you want to process the single sheet only.

**Processing Options**

You may select any combination of the following options:

- Quiet mode  
Turns quiet mode on.
- Do NOT change the sheet number  
Causes the sheet number set in the title block to remain unchanged. If this option is not selected, ANNOTATE renumbers all of the schematics in the design.
- Unannotate schematic  
Resets all of the reference designators in the design. When parts were first placed, the reference designator had a numeric component of "?". This option resets all numbers to "?".
- Report the last assigned reference values  
Tells ANNOTATE to report the last reference designator assigned to a design, after it is done annotating. The report is placed in a file with the same name as the source ending with the extension .END.
- Reset reference numbers to begin with 1 on each sheet of the hierarchy  
Restarts all reference designators used at 1 for each sheet of the design instead of only on the first sheet. This option is used when annotating a complex hierarchy. If you are using OrCAD's **Digital Simulation Tools** and your design is a complex hierarchy, this option is recommended.

Select one of the following:

- Incremental annotation (only update reference designators shown as ?)

Updates only the reference designators that have a "?". When new parts are placed on a sheet, the reference is not assigned a numeric value, but rather is given the unassigned designation of "?". If you do not wish to renumber all reference designators, including all previously set references, this option should be used.

- Unconditional annotation (update all reference designators)

Updates all reference designators in the order in which they are placed in the worksheet. All references are updated, even those that may have been assigned previously.

You may select this option:

- Ignore warnings

Causes ANNOTATE to continue running when it encounters warnings, instead of halting in the middle of execution.

## Local Configuration of INET

With the Schematic Design Tools screen displayed, select **To Digital Simulation**. Select **Local Configuration** from the menu that displays, and then select **Configure INET**. A configuration screen displays (figure 30-3).

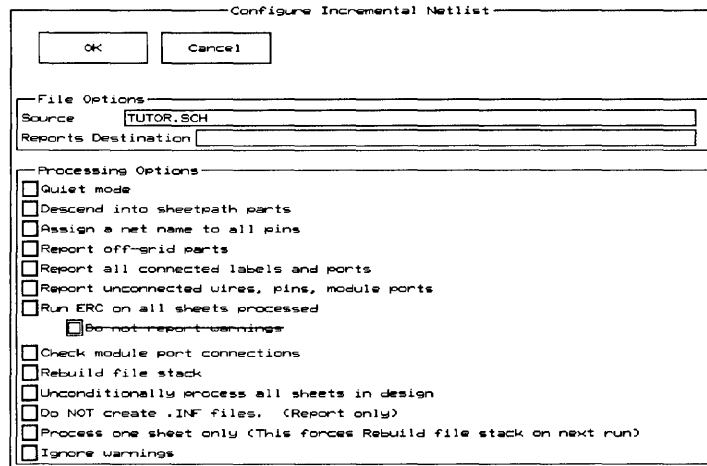

Figure 30-3. INET's local configuration screen.

**File Options** **File Options** defines the source file from which the incremental database files are created. It also defines the name of a file to contain data created by INET.

*Source* The **Source** is the root of the design or the filename of a single sheet. It may have any valid pathname. One .INF file is created for each sheet referenced by the root sheet.

*Reports Destination* The **Reports Destination** is the name of a file where the report is to be placed. This specification is optional. If a **Reports Destination** is not specified, the report is sent to the screen and the file #ESP\_OUT.TXT.

**Processing Options**

You may elect any combination of the following options:

- Quiet mode  
Turns quiet mode on.
- Descend into sheet path parts  
Tells INET to descend into parts defined as sheetpath parts. That is, it treats a sheetpath part as a sheet. This option, while designed for complex hierarchies, may be used in simple hierarchies. It is not recommended to be used except for FPGA, ASIC, or other designs that require a complex hierarchy.
- Assign a net name to all pins  
Tells INET to assign a net name to all pins, including unconnected ones.
- Report off-grid parts  
Tells INET to check the worksheet for parts, sheets, labels, module ports, and power objects that are off-grid.
- Report all connected labels and parts  
Tells INET to report all connected labels and module ports.
- Report unconnected wires, pins, module ports  
Tells INET to report all unconnected wires, pins, and module ports.
- Run ERC on all sheets processed  
Runs an electrical rules check on all sheets that INET processes. This is the same process provided by **Check Electrical Rules**.

- Do not report warnings

This option is available if you select the **Run ERC on all sheets processed** option. It tells INET to not test some of the conditions for which it normally issues warnings. The conditions are:

- ❖ Two power objects connected
- ❖ Single node nets
- ❖ Input signals without a driving source

These conditions are always checked—unless you select the **Do not report warnings** option—and cannot be changed with the **Check Electrical Rules Matrix**.

Use this option with caution. You may end up with a netlist containing conditions that are not acceptable.

- Check module port connections

Tells INET to check all module ports for correctness after tests and processing are completed.

- Rebuild file stack

Tells INET to rebuild the file stack that is used to determine the sheets that are in the incremental connectivity database. This file stack speeds the processing of the database when incremental updates occur. It may be viewed, but should not be modified. The file stack is given a .INX extension.

- Unconditionally process all sheets in design

Tells INET to ignore the incremental aspect of normal connectivity database processing. All sheets in the design are recompiled, even if the current database is up to date.

- Do NOT create .INF files (report only)

When processing the design, you may wish to leave the incremental connectivity database unchanged and only review the reports. This option causes all checks to be run and reports to be created, but does not update the incremental connectivity database.

- Process one sheet only (This forces Rebuild file stack on the next run)

Tells INET to produce an incremental connectivity database for a single sheet in a design. This option is useful for troubleshooting netlist problems. The next time INET runs, it will also rebuild the file stack used to determine the sheets that are in an incremental connectivity database.

- Ignore warnings

Causes INET to continue running when it encounters warnings, instead of halting in the middle of execution.

## Local Configuration of IBUILD

With the Schematic Design Tools screen displayed, select **To Digital Simulation**. Select **Local Configuration** from the menu that displays, and then select **Configure IBUILD**. A configuration screen displays (figure 30-4).

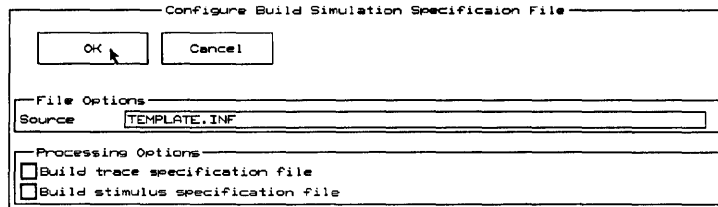

Figure 30-4. IBUILD's local configuration screen.

**File Options** **File Options** defines the source file from which the simulation directives are to be obtained. This source file is the incremented connectivity database.

*Source* The **Source** is the connectivity database. It has an extension of .INF and a base name that is the same as the project. It may have any valid pathname.

**Processing Options** Select any combination of the following:

- Build trace specification file  
Causes the trace objects in the schematic database to be updated as a new trace specification file for the simulation.
- Build stimulus specification file  
Causes the stimulus and vector (a vector is a form of a stimulus specification) objects in the schematic database to be updated as a new stimulus specification file for the simulator.



## Local Configuration of ASCTOVST

With the **Schematic Design Tools** screen displayed, select **To Digital Simulation**. Select **Local Configuration** from the menu that displays, and then select the one of the two instances of ASCTOVST. A configuration screen displays.

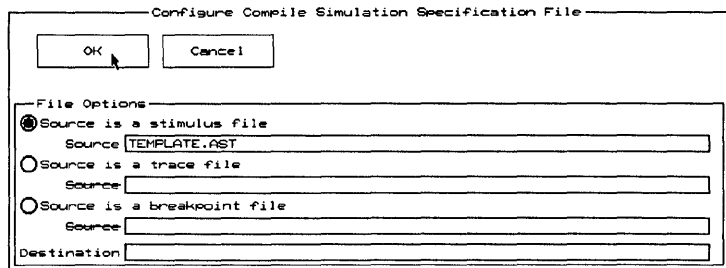

Figure 30-5. ASCTOVST's local configuration screen.

ASCTOVST displays twice so you can convert both the stimulus and trace files when transferring to **Digital Simulation Tools**. Usually, you configure the first instance to select **Source is a stimulus file** and the second instance to select **Source is a trace file**.

**File Options**      **File Options** specifies the source and destination filenames.

*Source*      Select one of the following options:

- Source is a stimulus file

The source is a stimulus file. Enter the destination path and filename. The default is your design directory name followed by an .AST extension. Select this default file option for the first instance.

- Source is a trace file

The source is a trace file. Enter the destination path and filename. The default is your design directory name followed by an .ATR extension. Select this file option for the second instance.

- Source is a breakpoint file

The source is a breakpoint file. Enter the destination path and filename. The default is your design directory name followed by an .ABR extension.

*Destination*    The directory path and filename for the output file.





## To Layout

### About To Layout

The **To Layout** transfer consists of four processes that are used to update the connectivity database and the layout directives given in the schematics. These processes are:

- ❖ **FLDSTUFF** loads user-defined information into part fields on a specified schematic.

**FLDSTUFF** constructs a string from the key field designators for a specified field. Then, if that string equals a match field in a designated update file, it replaces the specified field with the update value.

For more information about this process, see *Chapter 13: Update Field Contents*.

- ❖ **ANNOTATE** scans a design and updates the reference designators of all parts in the worksheet.

**ANNOTATE** updates reference designators in the order they were placed in the worksheet. When the worksheet is annotated, all parts may be assigned a new reference designator, including any manually edited parts. To selectively change reference designators and leave others unmodified, use **Draft**.

For more information about this process, see *Chapter 6: Annotate Schematic*.

- ❖ **INET** updates the connectivity database for the design. **INET** updates the database only for those worksheets that have been changed.
- ❖ **ILINK** links the incremental database into a flattened database. This flattened database contains information on the connectivity, parts, fields, pin typing information, and the layout directives.

---

## Execution

**To Layout** updates the schematic database, the connectivity database, and the layout directives used in **PC Board Layout Tools**. The design may be a simple hierarchy or a flat design. If the design is a complex hierarchy, the **Complex to Simple** processor in **Design Management Tools** must be used to simplify the design hierarchy before you select **To Layout**.

### Running To Layout

With the **Schematic Design Tools** screen displayed, select **To Layout**. Select **Execute** from the menu that displays.

When the transfer process is complete, the **PC Board Layout Tools** screen displays.

---

## Local Configuration of To Layout

Since **FLDSTUFF**, **ANNOTATE**, **INET**, and **ILINK** are each configured individually, **To Layout** has four configuration screens. To configure **To Layout**, select **To Layout**. Select **Local Configuration** from the menu that displays.

The menu shown at right displays. Use this menu to choose which **To Layout** process to configure and to turn a process on or off. When you select **To Layout**, only the processes that are turned on run. In most cases, you will have **INET** and **ILINK** turned on and the other processes turned off.

|           |          |
|-----------|----------|
| Configure | FLDSTUFF |
| Configure | ANNOTATE |
| Configure | INET     |
| Configure | ILINK    |
| FLDSTUFF  | off      |
| ANNOTATE  | off      |
| INET      | on       |
| ILINK     | on       |

To turn a process on or off, choose the desired process from the menu. For example, to turn **FLDSTUFF** on, select **FLDSTUFF off** from the menu. **Schematic Design Tools** displays:

|  |
|--|
| Select the new status of the executable item |
|--|

A menu with the options **on** and **off** displays. Select **on** to turn the process on.

## Local Configuration of FLDSTUFF

With the **Schematic Design Tools** screen displayed, select **To Layout**. Select **Local Configuration** from the menu that displays, and then select **Configure FLDSTUFF**. A configuration screen displays (figure 31-1).

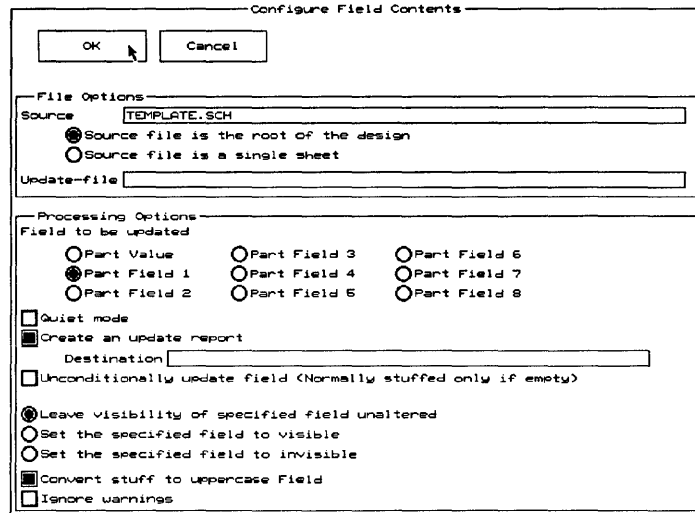

Figure 31-1. FLDSTUFF's local configuration screen.

### File Options

**File Options** defines the source file and its type. It also defines the update file.

#### Source

The **Source** is the filename of the design's root sheet or the filename of a single sheet. It may have any valid pathname. After entering the source filename, select one of the following:

- Source file is the root of the design

Specifies that the source file is the root sheet filename of a hierarchical or flat design.

- Source file is a single sheet

Specifies that the source file is a single worksheet and you want to process the single sheet only.

#### Update-file

The **Update-file** is a text file that you create. The file format is described in *Chapter 13: Update Field Contents*.

**Processing Options**

Select one of the following options to define which field is to be updated:

- Part Value
- Part Field 1
- Part Field 2
- Part Field 3
- Part Field 4
- Part Field 5
- Part Field 6
- Part Field 7
- Part Field 8

The field parameter selected above also identifies a key field designator. There are nine key field designators, one for the part's value, and one for each of the eight part fields. They are found on the **Configure Schematic Design Tools** screen as shown in figure 31-2.

|                       |                      |
|-----------------------|----------------------|
| Update Field Contents |                      |
| Combine for Value     | <input type="text"/> |
| Combine for Field 1   | <input type="text"/> |
| Combine for Field 2   | <input type="text"/> |
| Combine for Field 3   | <input type="text"/> |
| Combine for Field 4   | <input type="text"/> |
| Combine for Field 5   | <input type="text"/> |
| Combine for Field 6   | <input type="text"/> |
| Combine for Field 7   | <input type="text"/> |
| Combine for Field 8   | <input type="text"/> |

Figure 31-2. Key field designators for FLDSTUFF.

FLDSTUFF constructs a string from the key field designator set up for the field parameter selected. For example, if you select "Part Field 3" and the **Update Field Contents Combine for Field 3** is V 2, then **Update Field Contents** constructs a string consisting of the part's value, a space, and Part Field 2.

FLDSTUFF then tries to match that string with the match fields listed in the update file. Each match field has a corresponding update field. If a match occurs, **Update Field Contents** replaces the contents of the field parameter (selected above) with the corresponding update field.

For additional information on key fields, see the *Schematic Design Tools User's Guide*.

The key fields shown are shared between this process and the **Update Field Contents** processor. For more information on the key fields and other operating characteristics, see *Chapter 13: Update Field Contents*.

Select any combination of the following options:

- Quiet mode  
Turns quiet mode on.
- Create an update report  
Creates a report listing all the parts on each sheet and whether a field is updated for each part. If this option is selected, the **Destination** entry box is used to specify where the report is written.
- Unconditionally update field (Normally stuffed only if empty)  
Unconditionally changes the specified field. By default a field is only updated if it is empty. That is, fields with values already in them are not updated.



Select one of the following options to indicate whether you want the updated field to be visible, invisible, or to stay in its current state:

- Leave visibility of specified field unaltered
- Set specified field to visible
- Set specified field to invisible

You may select either or both of these options:

- Convert match string to uppercase
- Ignore warnings

Causes FLDSTUFF to continue running when it encounters warnings, instead of halting in the middle of execution.

## Local Configuration of ANNOTATE

With the **Schematic Design Tools** screen displayed, select **To Layout**. Select **Local Configuration** from the menu that displays, and then select **Configure ANNOTATE**. A configuration screen appears (figure 31-3).

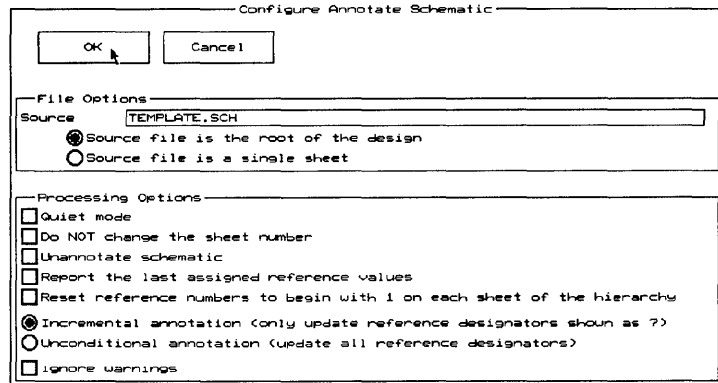

Figure 31-3. ANNOTATE's local configuration screen.

**File Options** File Options defines the source file and its type.

*Source* The **Source** is the root sheet filename of the design or the filename of a single sheet. It may have any valid pathname. After entering the source filename, select one of the following:

- Source file is the root of the design  
Specifies that the source file is the root sheet filename of a hierarchical or flat design. If the root sheet contains sheet symbols, then the design is hierarchical. If it contains a |Link, it is a flat design.
- Source file is a single sheet  
Specifies that the source file is a single worksheet and you want to process the single sheet only.

**Processing Options** You may select any combination of the following options:

- Quiet mode  
Turns quiet mode on.
- Do NOT change the sheet number  
Causes the sheet number set in the title block to remain unchanged. If this option is not selected, ANNOTATE renumbers all of the schematics in the design.
- Unannotate schematic  
Resets all of the reference designators in the design. When parts were first placed, the reference designator had a numeric component of "?". This option resets all number to "?".
- Report the last assigned reference values  
Tells ANNOTATE to report the last reference designator assigned to a design, after it is done annotating. The report is placed in a file with the same name as the source ending with the extension .END.
- Reset reference numbers to begin with 1 on each sheet of the hierarchy  
Restarts all reference designators used at 1 for each sheet of the design instead of only on the first sheet. This option is used when annotating a complex hierarchy. If you are using OrCAD's **Digital Simulation Tools** and your design is a complex hierarchy, this option is recommended.

Select one of the following options:

- Incremental annotation (only update reference designators shown as ?)

Updates only the reference designators that have a "?". When new parts are placed on a sheet, the reference is not assigned a numeric value, but rather is given the unassigned designation of "?". If you do *not* wish to renumber all reference designators, including all previously set references, use this option.

- Unconditional annotation (update all reference designators)

Updates all reference designators in the order in which they are placed in the worksheet. All references are updated, even those that may have been assigned previously.

You may select this option:

- Ignore warnings

Causes ANNOTATE to continue running when it encounters warnings, instead of halting in the middle of execution.

## Local Configuration of INET

With the Schematic Design Tools screen displayed, select **To Layout**. Select **Local Configuration** from the menu that displays, and then select **Configure INET**. A configuration screen displays (figure 31-4).

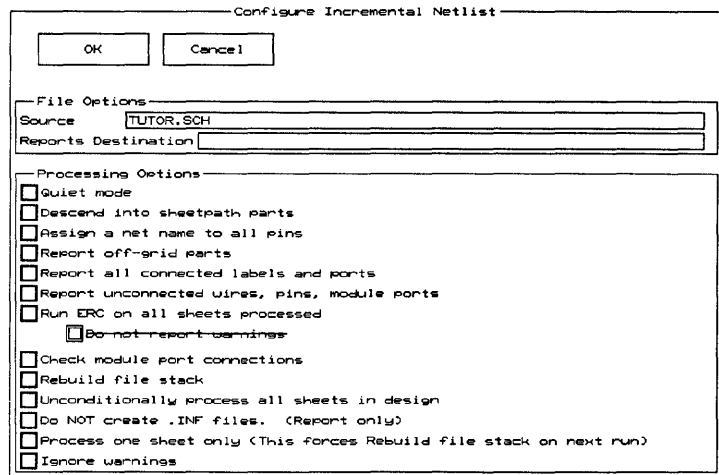

Figure 31-4. INET's local configuration screen.

**File Options** **File Options** defines both the source file from which the incremental connectivity database files are created and the name of a file to contain data created by INET.

*Source* The **Source** is the root of the design or the filename of a single sheet. It may have any valid pathname. One .INF file is created for each sheet referenced by the source.

*Reports Destination* The **Reports Destination** is the name of a file where the report is to be placed. This specification is optional. If a **Reports Destination** is not specified, the report is sent to the screen and the file #ESP\_OUT.TXT.

**Processing Options** You may select any combination of the following options:

- Quiet mode  
Turns quiet mode on.
- Descend into sheet path parts  
Tells INET to descend into parts defined as sheetpath parts. That is, it treats a sheetpath part as a sheet. This option, while designed for complex hierarchies, may be used in simple hierarchies. It is not recommended to be used except for FPGA, ASIC, or other designs that require a complex hierarchy.
- Assign a net name to all pins  
Tells INET to assign a net name to all pins, including unconnected ones.
- Report off-grid parts  
Tells INET to check the worksheet for parts, sheets, labels, module ports, and power objects that are off-grid.
- Report all connected labels and parts  
Tells INET to report all connected labels and module ports.
- Report all unconnected wires, pins, module ports  
Tells INET to report all unconnected wires, pins, and module ports.

- Run ERC on all sheets processed

Runs an electrical rules check on all sheets that INET processes. This is the same process provided by **Check Electrical Rules**.

- Do not report warnings

This option is available if you select the **Run ERC on all sheets processed** option. It tells INET to not test some of the conditions for which it normally issues warnings. The conditions are:

- ❖ Two power objects connected
- ❖ Single node nets
- ❖ Input signals without a driving source

These conditions are always checked—unless you select the **Do not report warnings** option—and cannot be changed with the **Check Electrical Rules Matrix**.

Use this option with caution. You may end up with a netlist containing conditions that are not acceptable.

- Check all module port connections

Tells INET to check all module ports for correctness after tests and processing are completed.

- Rebuild file stack

Tells INET to rebuild the file stack that is used to determine the sheets that are in the incremental connectivity database. This file stack speeds the processing of the database when incremental updates occur. It may be viewed, but should not be modified. The file stack is given a .INX extension.

- Unconditionally process all sheets in design

Tells INET to ignore the incremental aspect of normal connectivity database processing. All sheets in the design are recompiled, even if the current database is up to date.

- Do NOT create .INF files (report only)  
When processing the design, you may wish to leave the incremental connectivity database unchanged and only review the reports. This option causes all checks to be run and reports to be created, but does not update the incremental connectivity database.
- Process one sheet only (This forces Rebuild file stack on the next run)  
Tells INET to produce an incremental connectivity database for a single sheet in a design. This option is useful for troubleshooting netlist problems. The next time INET runs, it will also rebuild the file stack used to determine the sheets that are in an incremental connectivity database.
- Ignore warnings  
Causes INET to continue running when it encounters warnings, instead of halting in the middle of execution.



## Local Configuration of ILINK

With the Schematic Design Tools screen displayed, select **To Layout**. Select **Local Configuration** from the menu that displays. Select **Configure ILINK**. A configuration screen displays (figure 31-5).

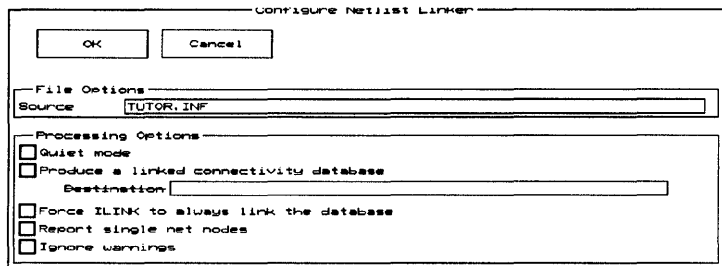

Figure 31-5. ILINK's local configuration screen.

**File Options** File Options defines the source file.

*Source* The **Source** is the incremental connectivity database root file. There *must* be an extension on the filename. The source file is the output from INET (discussed previously) and should have the recommended extension of .INF. It may have any valid pathname.

**Processing Options** You may select any combination of the following options:

- Quiet mode  
Turns quiet mode on.

- Produce a linked connectivity database  
Tells ILINK to produce a linked connectivity database (.LNF). This text file is read by **PC Board Layout Tools**. If a destination file is not supplied, the output is placed in a file with the same name as the source, except with a .LNF extension.  
  
A **Destination** may be supplied to override the default output file. This file may have any valid pathname.  
  
If this option is not selected, ILINK produces the intermediate netlist structure files (.INS, .RES, and .PIP). These binary files are used by the formatter, IFORM.
- Force ILINK to always link the database  
Tells ILINK to force a link of the database to occur, even if the database is up to date.
- Report single net nodes  
Reports all nodes that have only a single pin. This report is used to identify nodes that still need to be connected in the design.
- Ignore warnings  
Causes ILINK to continue running when it encounters warnings, instead of halting in the middle of execution.





## To Main

### About To Main

The **To Main** tool transfers from the **Schematic Design Tools** screen to the design environment's main screen. This tool does not process or create any files and has nothing for you to configure.

### Running To Main

With the **Schematic Design Tools** screen displayed, select **To Main**. Select **Execute** from the menu that displays. The design environment's main screen (figure 32-1) displays.

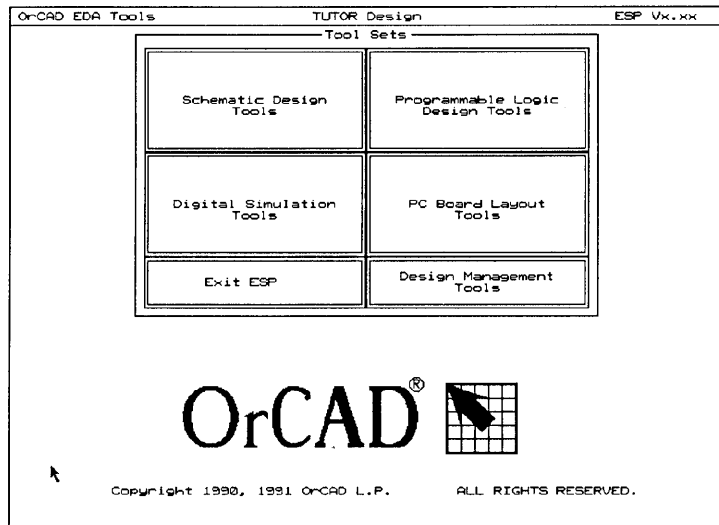

Figure 32-1. ESP 's main screen.





## *Command line controls*

This appendix cross references command line commands and their switches with their corresponding ESP tool and local configuration buttons. This appendix is organized in alphabetical order by command.

- △ *NOTE: Schematic Design Tools Release IV does not support the /F switch. Many version 3 utilities used the /F switch to indicate that the source file was a text file containing a list of files to be processed in a flat file structure. Release IV uses the |LINK command to list the files. For more information, see The |LINK command in Chapter 9: Creating a netlist.*

## ANNOTATE source [switches]

Corresponding ESP tool name: Annotate Schematic

| Switch | Description   | Local Configuration Button  |
|--------|---|---|
| /C     | Display the SDT configuration screen.   | None  |
| /H     | Reset reference numbers to begin with 1 for each sheet of the hierarchy.  | <input type="checkbox"/> Reset reference numbers to begin with 1 for each sheet of the hierarchy  |
| /L     | Create a report listing the last reference designators assigned by ANNOTATE. If a destination file is not specified, the report is placed in a text file with the same filename as the root worksheet and a file extension of .END. | <input type="checkbox"/> Report the last assigned reference values  |
| /O     | Treat this file as a single sheet.  | <input type="radio"/> Source file is a single sheet   |
| /Q     | Run in "quiet" mode without echoing tracking information on the screen.   | <input type="checkbox"/> Quiet mode   |
| /R     | Unannotate the schematic. All reference numbers are set to "?" and all reference letters (for multiple parts-per-package) are set to "A."   | <input type="checkbox"/> Unannotate Schematic   |
| /S     | Do not change the sheet number in the title block. If this switch is not set then the sheet numbers are changed to reflect the current sheet in the design.   | <input type="checkbox"/> Do NOT change the sheet number   |
| /U     | Change references unconditionally. <b>Annotate</b> updates reference designators in the order in which they were placed on the worksheet. If you add a part and run <b>Annotate /U</b> , all the reference designators are updated. | <input type="radio"/> Incremental annotation (only update reference designators shown as ?)<br>and<br><input type="radio"/> Unconditional annotation (update all reference designators) |
| /Z     | Cause warning messages to be ignored.   | <input type="checkbox"/> Ignore warnings  |

## BACKANNO source was/is [switches]

Corresponding ESP tool name: **Back Annotate**

| <i>Switch</i> | <i>Description</i>  | <i>Local Configuration Button</i>                   |
|---------------|---|---|
| /C            | Display the SDT configuration screen.                                   | None  |
| /O            | Treat this file as a single sheet.                                      | <input type="radio"/> Source file is a single sheet |
| /Q            | Run in "quiet" mode without echoing tracking information on the screen. | <input type="checkbox"/> Quiet mode                 |
| /Z            | Cause warning messages to be ignored                                    | <input type="checkbox"/> Ignore warnings            |

## CLEANUP source [destination] [switches]

Corresponding ESP tool name: **Cleanup Schematic**

| <i>Switch</i> | <i>Description</i>  | <i>Local Configuration Button</i>   |
|---------------|---|---|
| /C            | Display the SDT configuration screen.   | None  |
| /E            | Removes error markers placed on the schematic by <b>Check Electrical Rules</b> (INET /W). | <input type="checkbox"/> Remove error object from schematic sheet(s)                  |
| /G            | Report items found to be off grid.  | <input type="checkbox"/> Report off-grid items  |
| /O            | Treat this file as a single sheet.  | <input type="radio"/> Source file   |
| /Q            | Run in "quiet" mode without echoing tracking information on the screen.                   | <input type="checkbox"/> Quiet mode   |
| /R            | Repeat <b>CLEANUP</b> if it was too large to complete in one pass.                        | <input type="checkbox"/> Repeat CLEANUP if sheet is too large to complete in one pass |
| /Z            | Cause warnings to be ignored.   | <input type="checkbox"/> Ignore warnings  |



## COMPOSER source destination [switches]

Corresponding ESP tool name: **Compile Library**

| <i>Switch</i> | <i>Description</i>  | <i>Local Configuration Button</i>                |
|---------------|---|--|
| /N            | Do not sort library as it is compiled. Instead save devices in the order in which they appear in the source file. | <input type="checkbox"/> Do not sort the library |
| /Q            | Run in "quiet" mode without echoing tracking information on the screen.   | <input type="checkbox"/> Quiet mode              |

## CROSSREF

Corresponding ESP tool name: **Cross Reference Parts**

CROSSREF no longer exists as a separate program. It is now a part of PARTLIST. See PARTLIST in this chapter for details.

## DECOMP library source [/Q]

Corresponding ESP tool name: **Decompile Library**

| <i>Switch</i> | <i>Description</i>  | <i>Local Configuration Button</i>   |
|---------------|---|-------------------------------------|
| /Q            | Run in "quiet" mode without echoing tracking information on the screen. | <input type="checkbox"/> Quiet mode |

**DRAFT filename [switches]**Corresponding ESP tool name: **Draft**

| <i>Switch</i> | <i>Description</i>  | <i>Local Configuration Button</i>                                |
|---------------|---|--|
| /C            | Display SDT configuration screen.                                       | None   |
| /M            | Disable the mouse.  | <input type="checkbox"/> Disable mouse                           |
| /P            | Disable <b>Draft's</b> <Print Screen> key function.                     | <input type="checkbox"/> Disable <Print Screen> key function     |
| /Q            | Run in "quiet" mode without echoing tracking information on the screen. | <input type="checkbox"/> Quiet mode                              |
| /S            | Slow the mouse. Used for mice that are too sensitive.                   | <input type="checkbox"/> Decrease mouse sensitivity              |
| /Y            | Reverse the "Y" axis operation of the mouse.                            | <input type="checkbox"/> Reverse "Y" axis operation of the mouse |

**ERC source [destination] [switches]**Corresponding ESP tool name: **Check Electrical Rules**

ERC no longer exists as a separate program. It is now a part of INET. See *INET* in this chapter for details.

**EXTRACT source [switches]**Corresponding ESP tool name: **Extract PLD, in Programmable Logic Design Tools**

| <i>Switch</i> | <i>Description</i>                                       | <i>Local Configuration Button</i>  |
|---------------|--|--|
| /C            | Display the SDT configuration screen.                    | None   |
| /D            | Descend into sheetpath parts.                            | <input type="checkbox"/> Descend into sheetpath parts  |
| /O            | Treat this file as a single sheet.                       | <input type="radio"/> Source file is single sheet  |
| /P            | Extract PLD information ,                                | <input type="radio"/> Extract all PLD information  |
| /Q            | Run in the "quiet" mode,                                 | <input type="checkbox"/> Quiet mode  |
| /R            | Create a flat file listing of extracted files.           | <input type="checkbox"/> Produce a flat-file listing of extracted files                        |
| /S<br><arg>   | Extract information about the device specified by <arg>. | <input type="radio"/> Extract information on device<br>Extract Part Value <input type="text"/> |
| /Z            | Cause warnings to be ignored.                            | <input type="checkbox"/> Ignore warnings   |

## FLDATTRB source field [switches]

Corresponding ESP tool name: **Select Field View**

| <i>Switch</i> | <i>Description</i>   | <i>Local Configuration Button</i>                                     |
|---------------|--|---|
| /C            | Display the configuration screen.  | None  |
| /I            | Set specified field(s) to invisible.                                       | <input type="radio"/> Set the specified field to invisible            |
| /O            | Treat this file as a single sheet.   | <input type="radio"/> Source file is a single sheet                   |
| /Q            | Run in "quiet" mode without echoing tracking information on the screen.    | <input type="checkbox"/> Quiet mode                                   |
| /U            | Unconditionally set visibility parameter, even if nothing is in the field. | <input type="checkbox"/> Unconditionally set the visibility parameter |
| /V            | Set specified field(s) to visible.   | <input type="radio"/> Set the specified field to visible              |
| /Z            | Cause warnings to be ignored.  | <input type="checkbox"/> Ignore warnings                              |

**FLDSTUFF source field update-file [report file] [switches]**

Corresponding ESP tool name: Update Field Contents

| <i>Switch</i> | <i>Description</i>  | <i>Local Configuration Button</i>  |
|---------------|---|--|
| /C            | Display the configuration screen.   | None   |
| /I            | Specify that this field will be invisible.  | <input type="radio"/> Set the specified field to invisible                             |
| /K            | Keep visibility the same for all fields.  | <input type="radio"/> Leave visibility of specified field unaltered                    |
| /N            | Do not convert match string to uppercase.   | <input type="checkbox"/> Convert match string to uppercase                             |
| /O            | Treat this file as a single sheet.  | <input type="radio"/> Source file is a single sheet                                    |
| /Q            | Run in "quiet" mode.  | <input type="checkbox"/> Quiet mode  |
| /R            | Create a report of all FLDSTUFF activity. Enter the name of the report file to use after entering the name of the stuff file. | <input type="checkbox"/> Create an update report                                       |
| /U            | Unconditionally change this field. Normally it is only changed if it is empty.  | <input type="checkbox"/> Unconditionally update field (Normally stuffed only if empty) |
| /V            | Specify that this field will be visible.  | <input type="radio"/> Set the specified field to visible                               |
| /Z            | Cause warnings to be ignored.   | <input type="checkbox"/> Ignore warnings   |

## HFORM source format destination [destination 2] [switches]

Corresponding ESP tool name: Create Hierarchical Netlist

HFORM is Create Hierarchical Netlist's incremental hierarchical netlist formatter. An extension of .INF is assumed for the source. The format file is the path and filename of the netlist format file. OrCAD hierarchical netlist format files have an extension of .CH. A destination must be specified. If the netlist format requires two output files, destination 2 must be present on the command line.

| Switch | Description   | Local Configuration Button  |
|--------|---|---|
| /2     | Make two output files. Valid for SPICE only.                      | None.   |
| /B     | Bypass the .INX check and force a link even if it is not required | <input type="checkbox"/> Force HFORM to always create a formatted netlist |
| /I     | Assign all unconnected pins a unique net. Valid for SPICE only.   | <input type="checkbox"/> Include unconnected pins                         |
| /L     | Does not add the sheet number to label descriptions.              | <input type="checkbox"/> Do not append sheet number to labels             |
| /N     | Use node names. Valid for SPICE only.                             | <input type="checkbox"/> Use node names                                   |
| /P     | Output pin numbers instead of pin names. Valid for EDIF only.     | <input type="checkbox"/> Output pin numbers (instead of pin names)        |
| /Q     | Run in "quiet" mode.  | <input type="checkbox"/> Quiet mode                                       |
| /Z     | Cause warnings to be ignored.                                     | <input type="checkbox"/> Ignore warnings                                  |

**IFORM source format [destination] [destination 2] [switches]**

Corresponding ESP tool name: Create Netlist

IFORM is Create Netlist's incremental netlist formatter. An extension of .INS is assumed for the source. The format file is the path and filename of the netlist format file. OrCAD flat netlist format files have an extension of .CF. A destination must be specified. If the netlist format requires two output files (for example, RascalRedac), destination 2 must be present on the command line.

| <i>Switch</i> | <i>Description</i>   | <i>Local Configuration Button</i>   |
|---------------|--|---|
| /2            | Make two output files. Valid for these netlist formats: Calay Mentor, PADSASC, RACALRED, SPICE, and Vectron.           | None.   |
| /A            | Abbreviate label descriptions Valid for Wirelist format only.  | <input type="checkbox"/> Abbreviate label descriptions                      |
| /B            | Bypass the .INX check and force a link even if it is not required.   | <input type="checkbox"/> Force IFORM to always create a formatted netlist   |
| /I            | Assign all unconnected pins a unique net. Valid for these netlist formats: SPICE AlteraAD, IntelADF, Case, Hilo, PCAD. | <input type="checkbox"/> Include unconnected pins                           |
| /K            | Create CON* symbols for module ports. Valid for FutureNet format only.   | <input type="checkbox"/> Create CON* symbols for module ports               |
| /L            | Does not append the sheet number to labels. Valid for all formats except: DUMP, EEDesign, PDUMP, and VSTModel.         | <input type="checkbox"/> Do not append sheet number to labels               |
| /M            | Assign SIG* attributes to module ports. Valid for FutureNet format only.   | <input type="checkbox"/> Assign SIG* attributes to module ports             |
| /N            | FutureNet format only: Create a netlist instead of a pinlist.  | <input type="checkbox"/> Create a netlist (instead of a pinlist)            |
| /N            | AlteraAD, IntelADF, and VSTModel format only: Suppress comments.   | <input type="checkbox"/> Suppress comments                                  |
| /N            | SPICE format only: Use node names.   | <input type="checkbox"/> Use node names                                     |
| /P            | EDIF and FutureNet formats: Output pin numbers instead of pin names.   | <input type="checkbox"/> Output pin numbers (instead of pin names)          |
| /P            | Wirelist format only: Skip any non-numerical pin numbers.  | <input type="checkbox"/> Do not output pin numbers for Grid Array parts     |
| /Q            | Run in "quiet" mode.   | <input type="checkbox"/> Quiet mode   |
| /V            | Assign FutureNet power attributes to power objects. Valid for FutureNet format only.                                   | <input type="checkbox"/> Assign FutureNet power attributes to power objects |
| /Z            | Cause warnings to be ignored.  | <input type="checkbox"/> Ignore warnings                                    |

## ILINK source [switches]

Corresponding ESP tool name: **Create Netlist**

ILINK is the incremental netlist linker. The source is the .INF file of the incremental netlist files to be linked. The linker creates two files with the name of the source and extensions of .INS (instance file) and .RES (joined resolved file). These files are used by IFORM to produce the final version of the netlist.

| <i>Switch</i> | <i>Description</i>   | <i>Local Configuration Button</i>                                |
|---------------|--|--|
| /B            | Bypass the .INX check and force a link even if it is not required.                     | <input type="checkbox"/> Force ILINK to always link the database |
| /C            | Display the SDT configuration screen.  | None   |
| /F            | Produce a .LNF file (linked incremental netlist format). The .LNF file is used by PCB. | <input type="checkbox"/> Produce a linked connectivity database  |
| /I            | Include unconnected pins.  | <input type="checkbox"/> Report single net nodes                 |
| /Q            | Run in "quiet" mode without echoing tracking information on the screen.                | <input type="checkbox"/> Quiet mode                              |
| /Z            | Cause warning messages to be ignored.  | <input type="checkbox"/> Ignore warnings                         |

**INET source [destination] [switches]**

Corresponding ESP tool name: **Create Netlist and Create Hierarchical Netlist.**

*NOTE: INET is the incremental netlister. It creates a file with the name of the source and an extension of .INF. If the source file is not newer than an existing .INF file with the same name, an incremental netlist is not created.*

| Switch | Description  | Local Configuration Button   |
|--------|--|--|
| /B     | Build the file stack from schematics rather than the .INX file.  | <input type="checkbox"/> Rebuild file stack  |
| /C     | Display the SDT configuration screen.  | None   |
| /D     | Descend into sheetpath parts.  | <input type="checkbox"/> Descend into sheetpath parts  |
| /G     | Check worksheet for parts, sheets, labels, module ports, and power objects placed off grid. Report is placed in a .GRD file.   | <input type="checkbox"/> Report off-grid parts   |
| /I     | Assign a net name to all pins, even unconnected ones.  | <input type="checkbox"/> Assign a net name to all pins                                       |
| /L     | Report all connected labels and module ports. The report is placed in a .LAB file.   | <input type="checkbox"/> Report all connected labels and ports                               |
| /N     | Do not rebuild the .INF file.  | <input type="checkbox"/> Do NOT create .INF files (Report only)                              |
| /O     | Process one sheet only.  | <input type="checkbox"/> Process one sheet only (This forces Rebuild file stack on next run) |
| /Q     | Run in "quiet" mode without echoing tracking information on the screen.  | <input type="checkbox"/> Quiet mode  |
| /T     | Rebuild the entire database, recreate all connecting database files.   | <input type="checkbox"/> Unconditionally process all sheets in design                        |
| /U     | Report all unconnected wires and pins. The report is placed in a .NC file. This switch also checks for pins, module ports, and power objects that might be overlapping and reports them.   | <input type="checkbox"/> Report unconnected wires, pins, module ports                        |
| /W     | Run an electrical rules check on all files that are netlisted. If a destination is supplied, then the output is placed in the indicated file, otherwise standard out is used. Module ports are checked for correctness after all incremental netlisting and electrical rules checking is complete. | <input type="checkbox"/> Run ERC on all sheets processed<br>Destination <input type="text"/> |
| /X     | Check module port connections.   | <input type="checkbox"/> Check module port connections                                       |
| /Z     | Cause warnings to be ignored.  | <input type="checkbox"/> Ignore warnings   |



## LIBARCH source [destination] [switches]

Corresponding ESP tool name: **Archive Parts in Schematic**

| Switch | Description   | Local Configuration Button                            |
|--------|---|---|
| /C     | Display the SDT configuration screen.   | None  |
| /D     | Descend into any parts defined as sheetpath parts.  | <input type="checkbox"/> Descend into sheetpath parts |
| /L     | Make an ASCII file consisting of the names of all parts used in a schematic. This file is called a "string file." The names are delimited with single quotes, and each exists on a separate line. | <input type="radio"/> Output is a string file         |
| /O     | Treat this file as a single sheet.  | <input type="radio"/> Source file is a single sheet   |
| /Q     | Run in "quiet" mode without echoing tracking information on the screen.   | <input type="checkbox"/> Quiet mode                   |
| /S     | Treat the source file as a "string file." LIBARCH constructs a library source file, ready for use by COMPOSER. IEEE parts are not supported.  | <input type="radio"/> Source file is a string file    |
| /Z     | Cause warnings to be ignored.   | <input type="checkbox"/> Ignore warnings              |

**LIBEDIT filename.LIB [switches]**Corresponding ESP tool name: **Edit Library**

| <i>Switch</i> | <i>Description</i>                                    | <i>Local Configuration Button</i>                            |
|---------------|---|--|
| /C            | Display the SDT configuration screen.                 | None   |
| /M            | Disable the mouse.                                    | <input type="checkbox"/> Disable mouse                       |
| /P            | Disable LIBEDIT's <Print Screen> key function.        | <input type="checkbox"/> Disable <Print Screen> key function |
| /S            | Slow the mouse. Used for mice that are too sensitive. | <input type="checkbox"/> Decrease mouse sensitivity          |
| /Y            | Reverse the "Y" axis operation of the mouse.          | <input type="checkbox"/> Reverse "Y" axis operation of mouse |

**LIBLIST filename.LIB [destination] [switches]**Corresponding ESP tool name: **List Libraries**

| <i>Switch</i> | <i>Description</i>  | <i>Local Configuration Button</i>  |
|---------------|---|--|
| /L            | Create a string file as the report from the library.                    | <input type="checkbox"/> Output is a string file                           |
| /Q            | Run in "quiet" mode without echoing tracking information on the screen. | <input type="checkbox"/> Quiet mode  |
| /S            | Print a report showing total number of devices in a library.            | <input type="checkbox"/> Report the total number of devices in the library |

## PARTLIST source [destination] [include] [switches]

**PARTLIST** performs the functions for either **Cross Reference Parts** (if the **/X** switch is present) or **Create Bill of Materials** (absence of the **/X** switch). Some of the switches described in the table below apply only when running a cross reference report, only when running a part list report, or when running either report. The columns at the right of the table (labeled **XRF** for **Cross Reference Part** and **BOM** for **Create Bill of Materials**) indicate when each switch applies.

| Switch | BOM | XRF | Description  | Local Configuration Button   |
|--------|-----|-----|--|--|
| /C     | ✓   | ✓   | Display the SDT configuration screen.  | None   |
| /D     | ✓   | ✓   | Descend into sheetpath parts.  | <input type="checkbox"/> Descend into sheetpath parts  |
| /E     | ✓   | ✓   | Report unmatched keys.   | None   |
| /I     | ✓   |     | Specify an include file to be added to the part list.  | <input type="checkbox"/> Merge an include file with partlist   |
| /L     | ✓   |     | Specifies that each part starts on a new line.   | <input type="checkbox"/> Place each part on a separate line  |
| /N     |     | ✓   | Sort output by name, then reference designator. If neither <b>/R</b> or <b>/N</b> is present, then both reports are done (one sorted by name and the other sorted by reference). | <input type="radio"/> Sort output by part value, then by reference designator                                      |
| /O     | ✓   | ✓   | Treat this file as a single sheet.   | <input type="radio"/> Source is a single sheet   |
| /P     |     | ✓   | Output the X,Y coordinates for all parts.  | <input type="checkbox"/> Report the X and Y grid coordinates for all parts   |
| /Q     | ✓   | ✓   | Run in "quiet" mode without echoing tracking information on the screen.  | <input type="checkbox"/> Quiet mode  |
| /R     |     | ✓   | Sort output by reference designator, then name. If neither <b>/R</b> or <b>/N</b> is present, then both reports are done (one sorted by name and the other sorted by reference). | <input type="radio"/> Sort output by reference designator  |
| /S     | ✓   | ✓   | Produce a single-spaced report rather than a double.   | <input type="radio"/> Produce a single spaced report<br>or<br><input type="radio"/> Produce a double spaced report |

|    |   |   |   |  |
|----|---|---|---|--|
| /T |   | ✓ | Report type mismatches for parts, such as mixing parts with single and multiple parts per package (U1 and U1A). | <input type="checkbox"/> Report type mismatch parts                    |
| /U |   | ✓ | List all unused parts in multiple-part packages.  | <input type="checkbox"/> Report unused parts in multiple-part packages |
| /V | ✓ |   | Output report in a verbose format.  | <input type="checkbox"/> Verbose report                                |
| /W |   | ✓ | Check for identical part references. There should be none.  | <input type="checkbox"/> Report identical part reference designators   |
| /X |   | ✓ | Print cross reference report.   | None   |
| /Y | ✓ | ✓ | Turns off the header at the beginning of each page of the report.   | <input type="checkbox"/> Do not insert a header for each page          |
| /Z | ✓ | ✓ | Cause warnings to be ignored.   | <input type="checkbox"/> Ignore warnings                               |

## PLOTALL source [destination] [switches]

Corresponding ESP tool name: Plot Schematic

| Switch | Description  | Local Configuration Button  |
|--------|--|---|
| /C     | Display the SDT configuration screen.  | None  |
| /D     | Descend into sheet path parts.   | <input type="checkbox"/> Descend into sheetpath parts   |
| /G     | Plot grid references around the border of output.                                | <input type="checkbox"/> Plot grid references around the worksheet border.  |
| /N     | Instruct PLOTALL to ignore "fill" commands.                                      | <input type="checkbox"/> Ignore "fill" commands   |
| /O     | Treat this file as a single sheet.   | <input type="radio"/> Source file is a single sheet   |
| /P     | Direct output to printer instead of plotter.                                     | <input type="radio"/> Send output to printer  |
| /Q     | Run in "quiet" mode without echoing tracking information on the screen.          | <input type="checkbox"/> Quiet mode   |
| /R     | Specify plotter using roll feed paper.   | <input type="radio"/> Plotter uses roll feed paper  |
| /S     | Specify a scale factor for plot output "###.###"                                 | <input type="radio"/> Manually set scale factor and/or X,Y offsets<br>and<br><input type="checkbox"/> Set Scale factor <input type="text"/>   |
| /U     | Use offsets for another paper size (for example, /UA means to use A-size paper). | <input type="radio"/> Use offsets for a specified sheet size<br><input type="radio"/> A <input type="radio"/> B <input type="radio"/> C <input type="radio"/> D <input type="radio"/> E |
| /W     | Specify wide paper in printer.   | <input type="radio"/> Printer has wide paper  |
| /X     | Specify an "X" offset for plot output "###.###".                                 | <input type="radio"/> Manually set scale factor and/or X,Y offsets<br>and<br><input type="checkbox"/> Set X, Y offsets X <input type="text"/>   |
| /Y     | Specify a "Y" offset for plot output "###.###".                                  | <input type="radio"/> Manually set scale factor and/or X,Y offsets<br>and<br><input type="checkbox"/> Set X, Y offsets Y <input type="text"/>   |

**PRINTALL source [destination] [switches]**

Corresponding ESP tool name: Print Schematic

| <i>Switch</i> | <i>Description</i>  | <i>Local Configuration Button</i>  |
|---------------|---|--|
| <i>/C</i>     | Display the SDT configuration screen.                                   | None   |
| <i>/D</i>     | Descend into sheetpath parts.   | <input type="checkbox"/> Descend into sheetpath parts                      |
| <i>/G</i>     | Print grid references around the border of the output.                  | <input type="checkbox"/> Print grid references around the worksheet border |
| <i>/N</i>     | Suppress pin numbers.   | <input type="checkbox"/> Suppress pin numbers on print                     |
| <i>/O</i>     | Treat this file as a single sheet.                                      | <input type="radio"/> Source is a single sheet                             |
| <i>/Q</i>     | Run in "quiet" mode without echoing tracking information on the screen. | <input type="checkbox"/> Quiet mode  |
| <i>/W</i>     | Specify wide paper in printer.  | <input type="radio"/> Printer has wide paper                               |

### **SIMPLE source destination [switches]**

Corresponding ESP tool name: **Complex to Simple in Design Management Tools**

| <i>Switch</i> | <i>Description</i>  | <i>Corresponding options<br/>(no local configuration)</i> |
|---------------|---|---|
| /C            | Display the SDT configuration screen.                                   | None  |
| /Q            | Run in "quiet" mode without echoing tracking information on the screen. | None  |
| /Z            | Cause warnings to be ignored.   | None  |

### **TREELIST source destination [switches]**

Corresponding ESP tool name: **Show Schematic Structure**

| <i>Switch</i> | <i>Description</i>  | <i>Local Configuration Button</i>                      |
|---------------|---|--|
| /C            | Display SDT configuration information.                                  | None   |
| /D            | Descend into sheetpath parts.   | <input type="checkbox"/> Descend into sheet path parts |
| /Q            | Run in "quiet" mode without echoing tracking information on the screen. | <input type="checkbox"/> Quiet mode                    |
| /Z            | Cause warnings to be ignored.   | <input type="checkbox"/> Ignore warnings               |



## *Netlist formats*

---

### Usage

This chapter discusses the various netlist formatters that OrCAD provides. These formatters may be selected via the local configuration of the **Create Netlist** and **Create Hierarchical Netlist** tools. See *Chapter 10: Create Netlist* and *Chapter 11: Create Hierarchical Netlist* for information on creating netlists in these formats.

To use these netlist formats (and get predictable results), you must follow certain rules when creating your schematics. *Chapter 3: Guidelines for creating designs* explains these rules clearly.

The following sections contain examples of each flat and hierarchical netlist format supplied with **Schematic Design Tools**. Each example explains the formatting options, if any, that are available for each netlist format.

Many of these formats impose restrictions on the length of various names (reference designator and label/module port names for instance). Some formats also restrict the set of legal characters that may be used. Where appropriate, the formats check the names for validity. When illegal names are encountered, the formats attempt to recover without losing information. Where this is possible, a warning is issued; where it is not, an error is issued.

Each formatter file includes a comment section at the top that explains the restrictions imposed by that particular netlist format. Refer to this header for the exact limitations imposed by your desired format.



These examples assume the **Create Netlist** key fields on the **Key Fields** area of the **Configure Schematic Design Tools** screen were configured this way:

|                      |                                |
|----------------------|--------------------------------|
| Create Netlist       |                                |
| Part Value Combine   | <input type="text" value="V"/> |
| Module Value Combine | <input type="text" value="1"/> |

In each of the example netlists that follow, the **Part Value Combine** key field (part value, represented by "V" in the example above) is shown in **bold** and the **Module Value Combine** key field (1st part field, represented by "1" in the example above) is shown in *bold italics*.

---

### Creating your own netlist format

The formatter files are written in a small, interpreted language whose syntax is similar to the programming language "C." *Appendix C* explains the syntax of the language, and all of the built-in functions and symbols.

---

### Flat netlists

To create a netlist in one of these flat formats, it is assumed that your schematic has already been simplified (if necessary), netlisted, and linked. These steps are fully explained in *Chapter 10: Create Netlist*.

Flat netlist formatter files are distinguished by a .CF file extension. They cannot be used by the **Create Hierarchical Netlist** processor (the two interpreter formats are similar, but process incompatible data structures).

### Example schematics

Five sample schematics are used to create the flat netlists in this section. The first schematic, figure B-1, is a general example suitable for digital-oriented designs. The schematic in figure B-2 is used by the two ADF netlists. Figure B-3 shows how to create a model for a part for OrCAD's **Digital Simulation Tools** using a schematic as the source. Figure B-4 is an analog design that demonstrates the SPICE netlist. Figure B-5 shows how to define the programming for a PLD for OrCAD's **Programmable Logic Design Tools** using a schematic as the source.

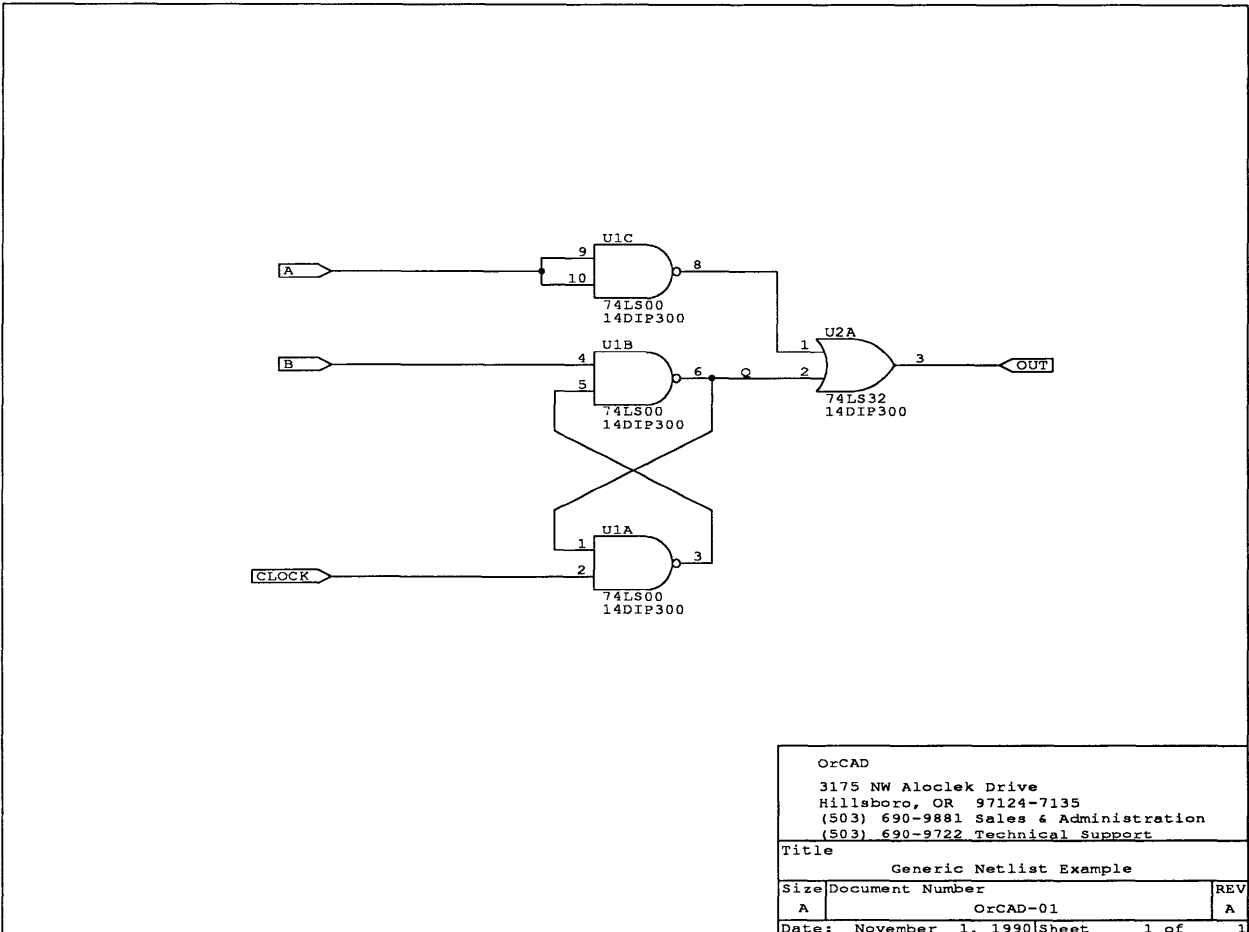

Figure B-1. Used by most of the flat netlist formats.

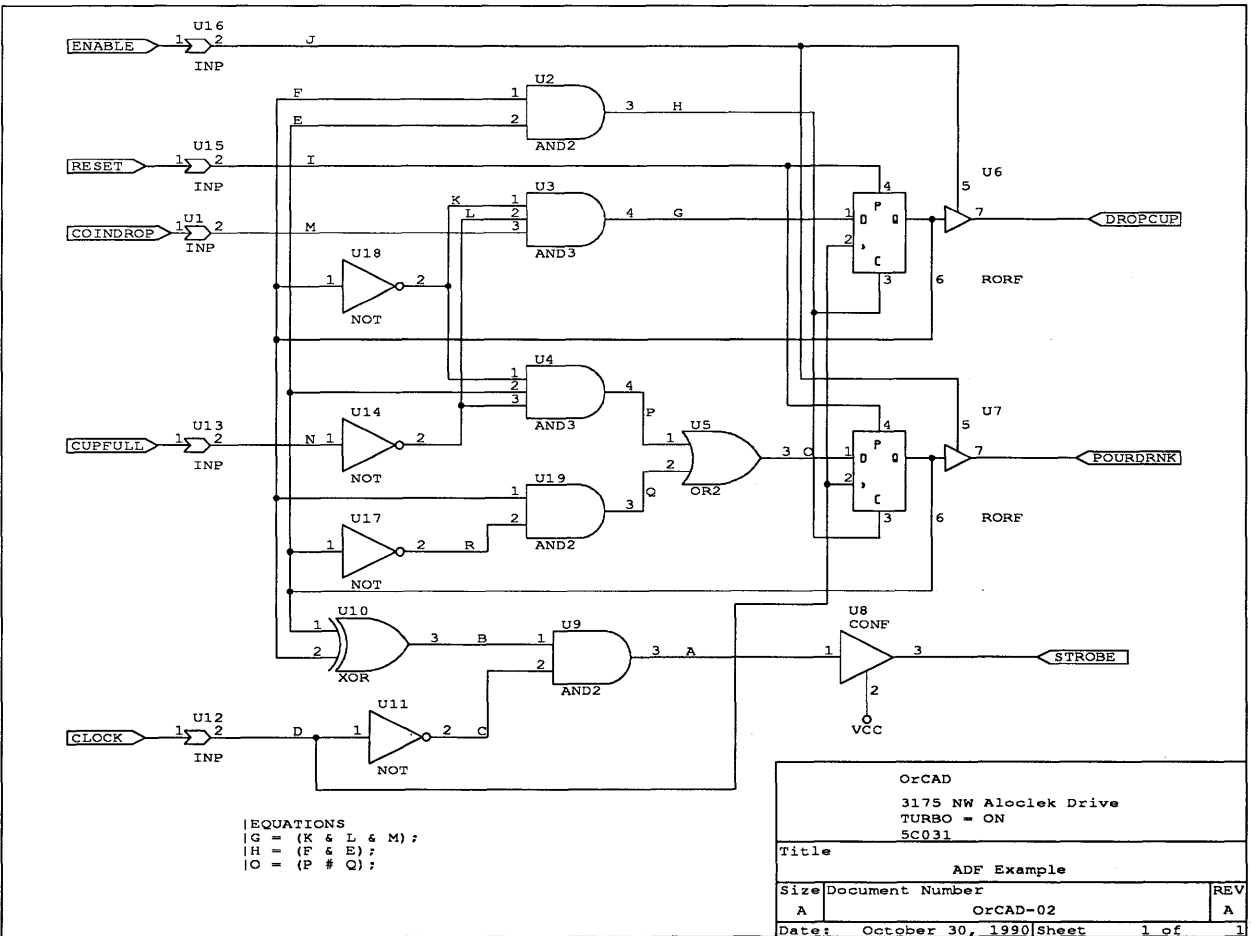

Figure B-2. Used by the AlteraADF and IntelADF formats.

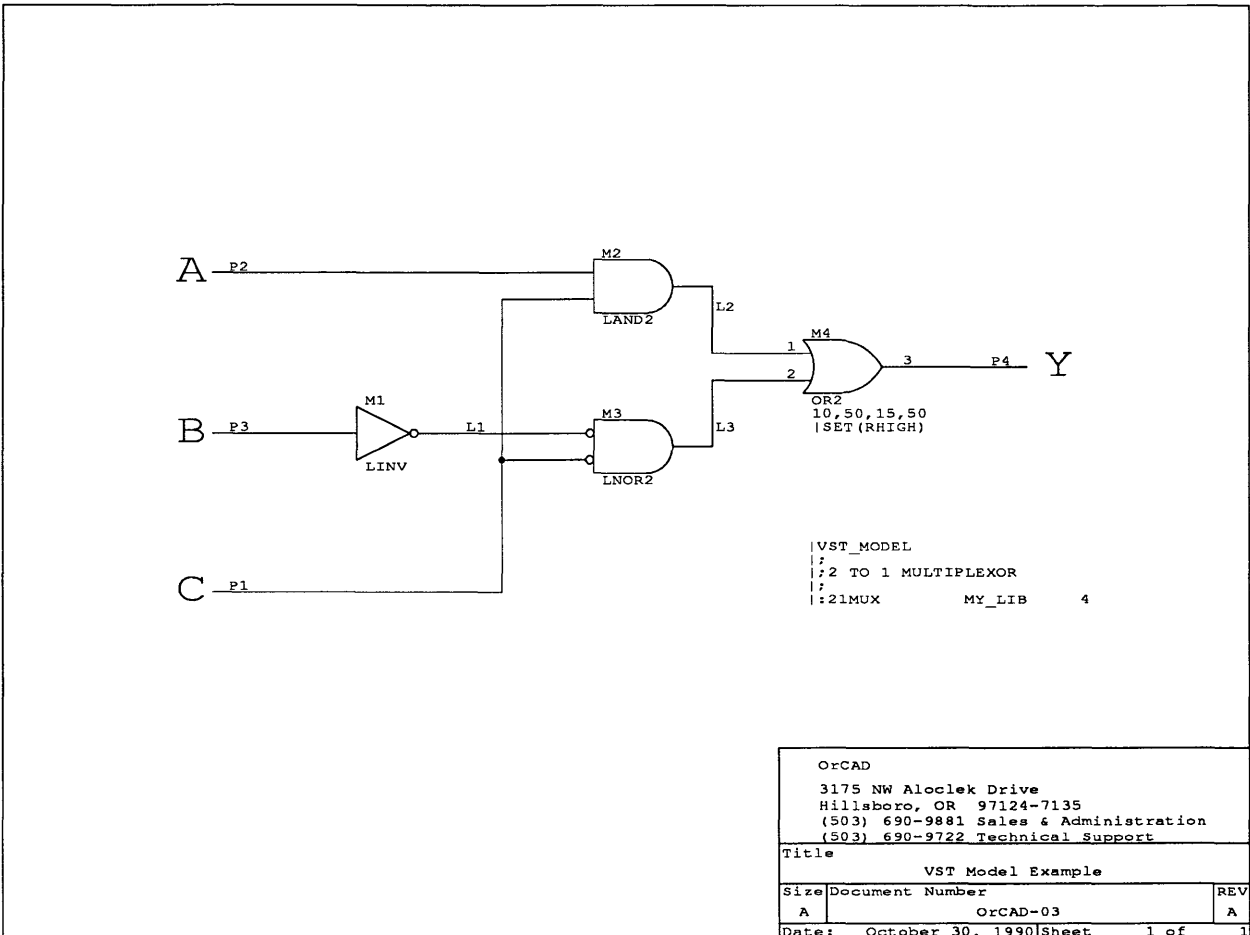
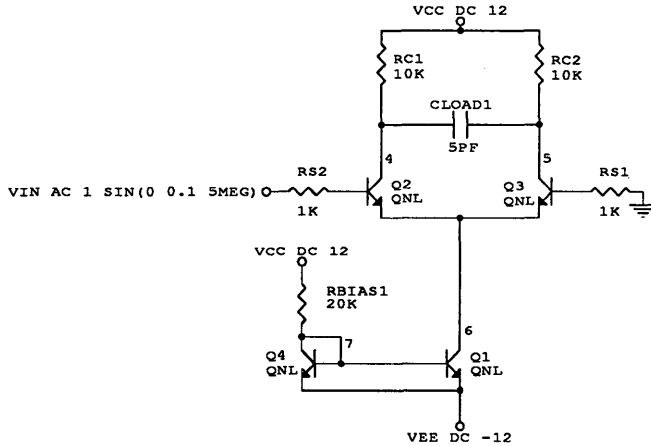

Figure B-3. Used by the OrCAD/VST Model format.



```

|SPICE
|.OPTIONS ACCT LIST NODE OPTS NOPAGE RELTOL=.001
|.WIDTH OUT=80
|.DC VIN -0.25 0.25 0.005
|.AC DEC 10 1 10GHZ
|.TRAN/OP SNS 50NS
|.MODEL QNL NPN (BF=80 RB=100 CJS=2PF
|+ TF=0.3NS TR=6NS VAF=50)
|.PRINT DC V(4) V(5)
|.PLOT DC IC(Q2)
|.PROBE
    
```

|   |                  |              |
|---|------------------|--------------|
| OrCAD<br>3175 NW Aloclek Drive<br>Hillsboro, OR 97124-7135<br>(503) 690-9881 Sales & Administration<br>(503) 690-9722 Technical Support |                  |              |
| Title<br>SPICE Example  |                  |              |
| Size  | Document Number  | REV          |
| A   | OrCAD-04         | A            |
| Date:   | October 30, 1990 | Sheet 1 of 1 |

Figure B-4. Used by the flat SPICE format.

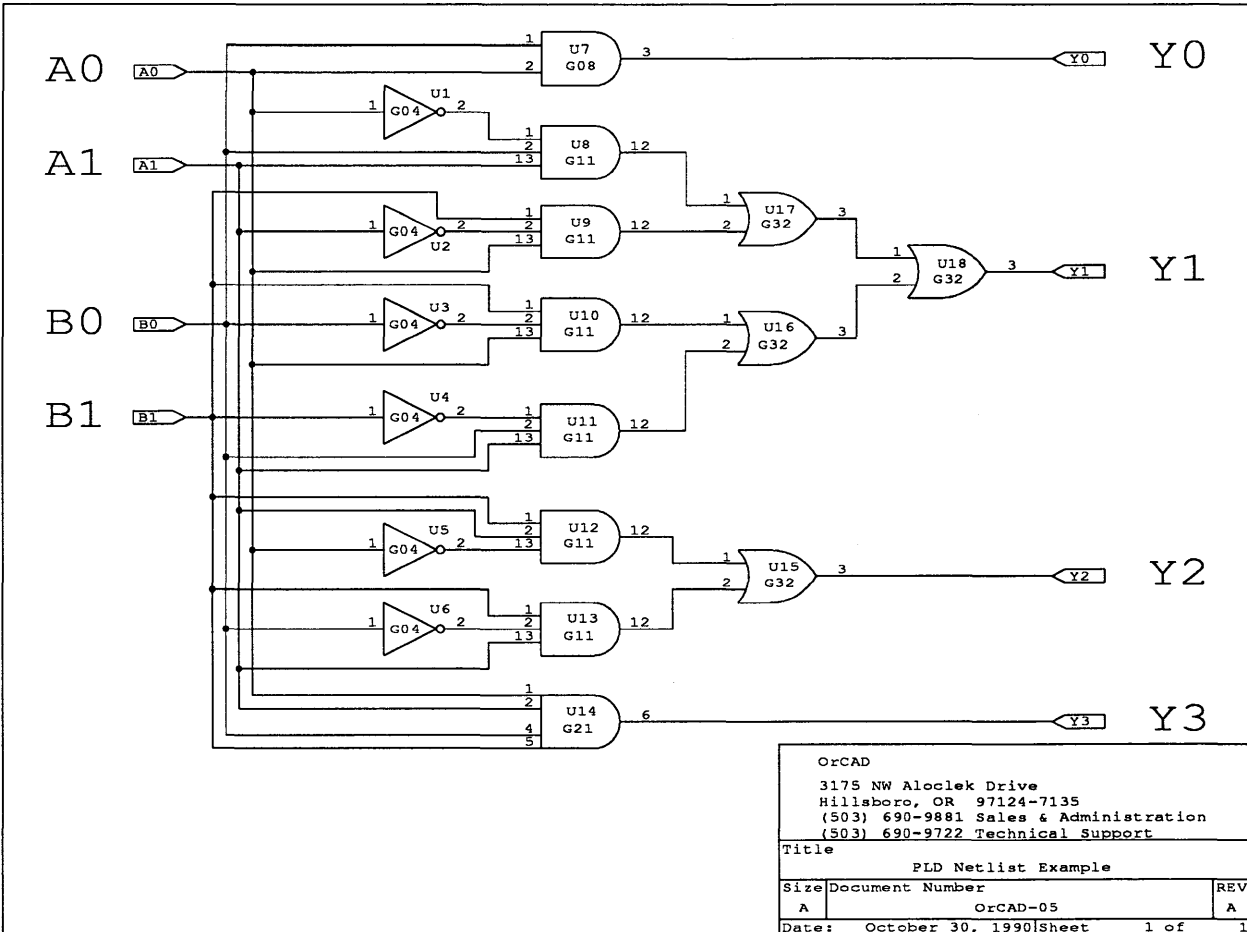

Figure B-5. Used by the OrCAD/PLD netlist format.

**Algorex  
(ALGOREX.CF)**

The only option available for the Algorex format is:

- Do not append sheet number to labels

If this option is not selected, the Algorex formatter appends a dash (-) and the sheet number to any labels.

▲ **CAUTION:** *If you select this option, labels with the same name on different sheets are merged into one net. This option is typically selected only when the design consists of a single schematic sheet.*

The netlist in figure B-6 was created from the schematic in figure B-1 with no options selected.

```

N00001
    U1 (14DIP300)-8,
    U2 (14DIP300)-1
Q-1
    U1 (14DIP300)-6,
    U2 (14DIP300)-2,
    U1 (14DIP300)-1
N00003
    U1 (14DIP300)-5,
    U1 (14DIP300)-3
VCC
    U2 (14DIP300)-14,
    U1 (14DIP300)-14
A
    U1 (14DIP300)-9,
    U1 (14DIP300)-10
GND
    U2 (14DIP300)-7,
    U1 (14DIP300)-7
B
    U1 (14DIP300)-4
OUT
    U2 (14DIP300)-3
CLOCK
    U1 (14DIP300)-2
    
```

Figure B-6. Example netlist in the Algorex format.

**Allegro  
(ALLEGRO.CF)**

The only option available for the Allegro format is:

- Do not append sheet number to labels

If this option is not selected, the Allegro formatter appends a slash (/) and the sheet number to any labels.

▲ **CAUTION:** *If you select this option, labels with the same name on different sheets are merged into one net. This option is typically selected only when the design consists of a single schematic sheet.*

The netlist in figure B-7 was created from the schematic in figure B-1 with no options selected.

```
$PACKAGES
14DIP300! 74LS00; U1
14DIP300! 74LS32; U2
$NETS
N00001; U1.8 U2.1
Q/1; U1.6 U2.2 U1.1
N00003; U1.5 U1.3
VCC; U2.14 U1.14
A; U1.9 U1.10
GND; U2.7 U1.7
B; U1.4
OUT; U2.3
CLOCK; U1.2
$END
```

Figure B-7. Example netlist in the Allegro format.



**AlteraADF  
(ALTERAAD.CF)**

Three formatting options are available for AlteraADF format.

- Suppress comments in the netlist file

If this option is selected, the formatter won't put comments in the resulting netlist file. Comments in the AlteraADF format are delimited by the percent (%) character.

- Include unconnected pins

If this option is selected, the AlteraADF formatter assigns all unconnected pins a unique net. If this option is not selected, the AlteraADF formatter assigns an unique net and reports an error.

- Do not append sheet number to labels

If this option is not selected, the AlteraADF formatter appends a period (.) and the sheet number to any labels.

▲ **CAUTION:** *If you select this option, labels with the same name on different sheets are merged into one net. This option is typically selected only when the design consists of a single schematic sheet.*

*Title block*

Title block information is placed in the first 10 lines of the netlist. Table B-1 shows an example netlist header and the title block information from which the header was extracted. Header information in **bold** is text entered in the schematic's title block.

| Line | Example Header               | Title Block Field |
|------|------------------------------|-------------------|
| 1    | <b>ADF Example</b>           | Title of sheet    |
| 1    | October 11, 1990             | Date              |
| 2    | <b>OrCAD-02</b>              | Document Number   |
| 2    | <b>A</b>                     | Revision Code     |
| 3    | <b>OrCAD</b>                 | Organization Name |
| 4    | <b>3175 NW Aloclek Drive</b> | 1st Address Line  |
| 6    | <b>Turbo = ON</b>            | 3rd Address Line  |
| 7    | <b>5C031</b>                 | 4th Address Line  |
| 9    | OPTIONS: <b>TURBO = ON</b>   |                   |
| 10   | PART: <b>5C031</b>           |                   |

Table B-1. Title block information in AlteraADF netlists.

*Pipe commands* You can place equations in your schematic to be included in the netlist. To place these equations in your worksheet, use the **Draft's PLACE Text** command. You can also use a text editor to put the equations in an ASCII file, then use **Draft's BLOCK ASCII Import** command to import the contents of the file and place it on the worksheet.

Each equation must start with the *pipe* character (`|`). (On many PC keyboards, the pipe character appears as a broken vertical bar). The first line must be:

```
|EQUATIONS
```

This tells the formatter that some AlteraADF equations need to be included in the netlist. The equations can contain any information you want to include in the netlist.

*Caveats* When you create an AlteraADF netlist, you must configure **Schematic Design Tools** to use the OrCAD-supplied ADF.LIB library. You can only use the parts provided in the ADF library to create the schematic.

Inputs and outputs are handled differently in **Schematic Design Tools** and the Altera software. **Schematic Design Tools** defines inputs and outputs with module ports and an input/output library object. Altera defines inputs and outputs with a library object which is then tagged with the appropriate pin number. In figure B-2, the CLOCK signal is an input and the STROBE signal is an output.

Additionally, library objects with unused pins default to pre-defined levels in the Altera software. Because **Schematic Design Tools** does not default unconnected pins to any particular level, you must tie all unused pins to the appropriate level.

The netlist in figure B-8 was created from the schematic in figure B-2 with no options selected.

```

ADF Example                               Revised:  October 30, 1990
OrCAD-02                                  Revision:  A
OrCAD
3175 NW Aloclek Drive

TURBO = ON
5C031

OPTIONS:TURBO = ON
PART:5C031

INPUTS:
  ENABLE
  RESET
  COINDROP
  CUPFULL
  CLOCK

OUTPUTS:
  DROPCUP
  POURDRNK
  STROBE

NETWORK:
H.1=AND(F.1,E.1) % SYM 1 %
A.1=AND(B.1,C.1) % SYM 2 %
Q.1=AND(F.1,R.1) % SYM 3 %
G.1=AND(K.1,L.1,M.1) % SYM 4 %
P.1=AND(K.1,E.1,L.1) % SYM 5 %
STROBE=CONF(A.1,VCC) % SYM 6 %
M.1=INP(COINDROP) % SYM 7 %
D.1=INP(CLOCK) % SYM 8 %
N.1=INP(CUPFULL) % SYM 9 %
I.1=INP(RESET) % SYM 10 %
J.1=INP(ENABLE) % SYM 11 %
C.1=NOT(D.1) % SYM 12 %
L.1=NOT(N.1) % SYM 13 %
R.1=NOT(E.1) % SYM 14 %
K.1=NOT(F.1) % SYM 15 %
O.1=OR(P.1,Q.1) % SYM 16 %
DROPCUP,F.1=RORF(G.1,D.1,H.1,I.1,J.1) % SYM 17 %
POURDRNK,E.1=RORF(O.1,D.1,H.1,I.1,J.1) % SYM 18 %
B.1=XOR(E.1,F.1) % SYM 19 %

EQUATIONS:
G = (K & L & M);
H = (F & E);
O = (P # Q);
ENDS

```

Figure B-8. Example netlist in the AlteraADF format.

**AppliconBRAVO  
(APPLBRAV.CF)**

The only option available for the AppliconBRAVO format is:

- Do not append sheet number to labels

If this option is not selected, the AppliconBRAVO formatter appends a dash (-) and the sheet number to any labels.

▲ **CAUTION:** *If you select this option, labels with the same name on different sheets are merged into one net. This option is typically selected only when the design consists of a single schematic sheet.*

The netlist in figure B-9 was created from the schematic in figure B-1 with no options selected.

```
*** Desig 14DIP300
U1
*** Desig 14DIP300
U2
*** NET N00001
U1 8
U2 1
*** NET Q-1
U1 6
U2 2
U1 1
*** NET N00003
U1 5
U1 3
*** NET VCC
U2 14
U1 14
*** NET A
U1 9
U1 10
*** NET GND
U2 7
U1 7
*** NET B
U1 4
*** NET OUT
U2 3
*** NET CLOCK
U1 2
```

Figure B-9. Example netlist in the AppliconBRAVO format.

**AppliconLEAP  
(APPLLEAP.CF)**

The only option available for the AppliconLEAP format is:

- Do not append sheet number to labels

If this option is not selected, the AppliconLEAP formatter appends a dash (-) and the sheet number to any labels.

- ▲ **CAUTION:** *If you select this option, labels with the same name on different sheets are merged into one net. This option is typically selected only when the design consists of a single schematic sheet.*

The netlist in figure B-10 was created from the schematic in figure B-1 with no options selected.

```
*** NET N00001
U1 8 14DIP300
U2 1 14DIP300
*** NET Q-1
U1 6 14DIP300
U2 2 14DIP300
U1 1 14DIP300
*** NET N00003
U1 5 14DIP300
U1 3 14DIP300
*** NET VCC
U2 14 14DIP300
U1 14 14DIP300
*** NET A
U1 9 14DIP300
U1 10 14DIP300
*** NET GND
U2 7 14DIP300
U1 7 14DIP300
*** NET B
U1 4 14DIP300
*** NET OUT
U2 3 14DIP300
*** NET CLOCK
U1 2 14DIP300
```

Figure B-10. Example netlist in the AppliconLEAP format.

**Cadnetix  
(CADNETIX.CF)**

The only option available for the Cadnetix format is:

- Do not append sheet number to labels

If this option is not selected, the Cadnetix formatter adds an underscore ( \_ ) and the sheet number to any labels.

▲ **CAUTION:** *If you select this option, labels with the same name on different sheets are merged into one net. This option is typically selected only when the design consists of a single schematic sheet.*

The netlist in figure B-11 was created from the schematic in figure B-1 with no options selected.

```

PARTS LIST
74LS00          14DIP300      U1
74LS32          14DIP300      U2
EOS
NET LIST
NODE      1          $
  U1      8  U2      1
NODENAME Q_1      $
  U1      6  U2      2  U1      1
NODE      3          $
  U1      5  U1      3
NODENAME VCC      $
  U2     14  U1     14
NODENAME A        $
  U1      9  U1     10
NODENAME GND      $
  U2      7  U1      7
NODENAME B        $
  U1      4
NODENAME OUT      $
  U2      3
NODENAME CLOCK   $
  U1      2
EOS
    
```

Figure B-11. Example netlist in the Cadnetix format.

**Calay (CALAY.CF)** Only one option is available for the Calay format:

- Do not append sheet number to labels

If this option is not selected, the Calay formatter appends a dash (-) and the sheet number to any labels.

▲ **CAUTION:** *If you select this option, labels with the same name on different sheets are merged into one net. This option is typically selected only when the design consists of a single schematic sheet.*

The Calay formatter creates two files. In addition to the netlist file, it also creates a component file. A second filename must be entered in the "Destination 2" entry box for the formatter.

The netlist in figure B-12 and its corresponding component file in figure B-13 were created from the schematic in figure B-1 with no options selected.

```

/N00001  U1 (8) U2 (1);
/Q-1     U1 (6) U2 (2) U1 (1);
/N00003  U1 (5) U1 (3);
/VCC     U2 (14) U1 (14);
/A       U1 (9) U1 (10);
/GND     U2 (7) U1 (7);
/B       U1 (4);
/OUT     U2 (3);
/CLOCK   U1 (2);

```

Figure B-12. Example netlist in the Calay format.

|               |    |                 |     |     |   |
|---------------|----|-----------------|-----|-----|---|
| <b>74LS00</b> | U1 | <b>14DIP300</b> | 000 | 000 | 0 |
| <b>74LS32</b> | U2 | <b>14DIP300</b> | 000 | 000 | 0 |

Figure B-13. Example component file in the Calay format.



**Case (CASE.CF)** Two options are available for the Case format. The first is:

- Do not append sheet number to labels

If this option is not selected, the Case formatter appends an underscore (\_) and the sheet number to any labels.

▲ **CAUTION:** *If you select this option, labels with the same name on different sheets are merged into one net. This option is typically selected only when the design consists of a single schematic sheet.*

The second option is:

- Include unconnected pins

If this option is selected, the Case formatter assigns all unconnected pins a unique net. If it is not selected, the Case formatter assigns an unique net and reports an error.

The netlist in figure B-14 was created from the schematic in figure B-1 with no options selected.

```
ASSERTIONS=OFF;VERSION=400;LOCATION=LOC;
[SIZE=1;TIMES=1;LOC=(U1);PLOC=U1;SHAPE=14DIP300]
1=Q_1;
2=CLOCK;
3=X00003;
4=B;
5=X00003;
6=Q_1;
7=GND;
8=X00001;
9=A;
10=A;
11=NC;
12=NC;
13=NC;
14=VCC;
;
[SIZE=1;TIMES=1;LOC=(U2);PLOC=U2;SHAPE=14DIP300]
1=X00001;
2=Q_1;
3=OUT;
4=NC;
5=NC;
6=NC;
7=GND;
8=NC;
9=NC;
10=NC;
11=NC;
12=NC;
13=NC;
14=VCC;
;
;
```

Figure B-14. Example netlist in the Case format.

**CBDS (CBDS.CF)** The only option available for the CBDS format is:

- Do not append sheet number to labels

If this option is not selected, the CBDS formatter appends a dash (-) and the sheet number to any labels.

▲ **CAUTION:** *If you select this option, labels with the same name on different sheets are merged into one net. This option is typically selected only when the design consists of a single schematic sheet.*

The netlist in figure B-15 was created from the schematic in figure B-1 with no options selected.

```
.SEARCH P,C
.DD U1 14DIP300
.DD U2 14DIP300
.S, N00001, U1, 8, U2, 1
.S, Q-1, U1, 6, U2, 2, U1, 1
.S, N00003, U1, 5, U1, 3
.S, VCC, U2, 14, U1, 14
.S, A, U1, 9, U1, 10
.S, GND, U2, 7, U1, 7
.S, B, U1, 4
.S, OUT, U2, 3
.S, CLOCK, U1, 2
```

Figure B-15. Example netlist in the CBDS format.

**ComputerVision  
(COMPVISN.CF)**

The only option available for the ComputerVision format is:

- Do not append sheet number to labels

If this option is not selected, the ComputerVision formatter appends a slash (/) and the sheet number to any labels.

▲ **CAUTION:** *If you select this option, labels with the same name on different sheets are merged into one net. This option is typically selected only when the design consists of a single schematic sheet.*

The netlist in figure B-16 was created from the schematic in figure B-1 with no options selected.

|             |       |       |      |
|-------------|-------|-------|------|
| 0001 N00001 | U1-8  | U2-1  |      |
| 0002 Q/1    | U1-6  | U2-2  | U1-1 |
| 0003 N00003 | U1-5  | U1-3  |      |
| 0004 VCC    | U2-14 | U1-14 |      |
| 0005 A      | U1-9  | U1-10 |      |
| 0006 GND    | U2-7  | U1-7  |      |
| 0007 B      | U1-4  |       |      |
| 0008 OUT    | U2-3  |       |      |
| 0009 CLOCK  | U1-2  |       |      |

Figure B-16. Example netlist in the ComputerVision format.

**EDIF (EDIF.CF)** This is one of two EDIF (Version 2 0 0) formatters supplied with **Schematic Design Tools**. This formatter can only be used to create flat EDIF netlists. The hierarchical EDIF formatter is discussed in the following section.

The first option available for the EDIF format is:

- Do not append sheet number to labels

If this option is not selected, the EDIF formatter appends an underscore (\_) and the sheet number to any labels.

▲ **CAUTION:** *If you select this option, labels with the same name on different sheets are merged into one net. This option is typically selected only when the design consists of a single schematic sheet.*

The EDIF formatter can also output pin numbers to the netlist instead of pin names.

- Output pin numbers (instead of pin names)

Not all parts have both pin names and pin numbers defined. If the option is selected, and a pin is encountered with no number, then the pin name is still used. If a netlist consisting entirely of pin numbers is required, you may need to modify the library part.

The netlist in figure B-17 was created from the schematic in figure B-1 with no options selected.

```
(edif &EX1
(edifVersion 2 0 0)
(edifLevel 0)
(keywordMap (keywordLevel 0))
(status
(written
(timeStamp 0 0 0 0 0 0)
(comment "Original data from OrCAD/SDT schematic"))
(comment "Original data from OrCAD/SDT schematic"))
(comment "Generic Netlist Example")
(comment " November 7, 1990")
(comment "OrCAD-01")
(comment "A")
(comment "OrCAD")
(comment "3175 NW Aloclek Drive")
```

Figure B-17. Example netlist in the EDIF format (continued).

```

(comment "Hillsboro, OR 97124-7135")
(comment "(503) 690-9881 Sales & Administration")
(comment "(503) 690-9722 Technical Support")
(external OrCAD_LIB
(edifLevel 0)
(technology
(numberDefinition
(scale 1 1 (unit distance))))
(cell &74LS00
(cellType generic)
(comment "From OrCAD library TTL.LIB")
(view NetlistView
(viewType netlist)
(interface
(port &IO_A (direction INPUT))
(port &IO_B (direction INPUT))
(port &IO_C (direction INPUT))
(port &IO_D (direction INPUT))
(port &I1_A (direction INPUT))
(port &I1_B (direction INPUT))
(port &I1_C (direction INPUT))
(port &I1_D (direction INPUT))
(port &O_A (direction OUTPUT))
(port &O_B (direction OUTPUT))
(port &O_C (direction OUTPUT))
(port &O_D (direction OUTPUT))
(port &VCC (direction INPUT))
(port &GND (direction INPUT))))))
(cell &74LS32
(cellType generic)
(comment "From OrCAD library TTL.LIB")
(view NetlistView
(viewType netlist)
(interface
(port &IO_A (direction INPUT))
(port &IO_B (direction INPUT))
(port &IO_C (direction INPUT))
(port &IO_D (direction INPUT))
(port &I1_A (direction INPUT))
(port &I1_B (direction INPUT))
(port &I1_C (direction INPUT))
(port &I1_D (direction INPUT))
(port &O_A (direction OUTPUT))
(port &O_B (direction OUTPUT))
(port &O_C (direction OUTPUT))
(port &O_D (direction OUTPUT))
(port &VCC (direction INPUT))
(port &GND (direction INPUT))))))
(library MAIN_LIB
(edifLevel 0)
(technology
(numberDefinition
(scale 1 1 (unit distance))))
(cell &EX1
(cellType generic)
(view NetlistView
(viewType netlist)
(interface
(port &A (direction INPUT))

```

Figure B-17. Example netlist in the EDIF format (continued).

```

(port &B (direction INPUT))
(port &OUT (direction OUTPUT))
(port &CLOCK (direction INPUT))
(contents
(instance &U1
(viewRef NetlistView
(cellRef &74LS00
(libraryRef OrCAD_LIB)))
(property PartValue (string "74LS00"))
(property ModuleValue (string "14DIP300")))
(instance &U2
(viewRef NetlistView
(cellRef &74LS32
(libraryRef OrCAD_LIB)))
(property PartValue (string "74LS32"))
(property ModuleValue (string "14DIP300")))
(net N00001
(joined
(portRef &O_C (instanceRef &U1))
(portRef &IO_A (instanceRef &U2))))
(net &Q_1
(joined
(portRef &O_B (instanceRef &U1))
(portRef &IO_A (instanceRef &U1))
(portRef &I1_A (instanceRef &U2))))
(net N00003
(joined
(portRef &I1_B (instanceRef &U1))
(portRef &O_A (instanceRef &U1))))
(net &VCC
(joined
(portRef &VCC (instanceRef &U2))
(portRef &VCC (instanceRef &U1))))
(net &A
(joined
(portRef &A)
(portRef &IO_C (instanceRef &U1))
(portRef &I1_C (instanceRef &U1))))
(net &GND
(joined
(portRef &GND (instanceRef &U2))
(portRef &GND (instanceRef &U1))))
(net &B
(joined
(portRef &B)
(portRef &IO_B (instanceRef &U1))))
(net &OUT
(joined
(portRef &OUT)
(portRef &O_A (instanceRef &U2))))
(net &CLOCK
(joined
(portRef &CLOCK)
(portRef &I1_A (instanceRef &U1))))))
(design &EX1
(cellRef &EX1
(libraryRef MAIN_LIB)))

```

Figure B-17. Example netlist in the EDIF format.

**EEDesigner  
(EEDESIGN.CF)**

The EEDesigner format has no customization options. The netlist in figure B-18 was created from the schematic in figure B-1.

```
(PATH,OrCAD ()
(COMPONENTS
U1 ,14DIP300
U2 ,14DIP300
)
(NODES
(UN001
U1 , 8
U2 , 1
)
(UN002
U1 , 6
U2 , 2
U1 , 1
)
(UN003
U1 , 5
U1 , 3
)
(UN004
U2 , 14
U1 , 14
)
(UN005
U1 , 9
U1 , 10
)
(UN006
U2 , 7
U1 , 7
)
(UN007
U1 , 4
)
(UN008
U2 , 3
)
(UN009
U1 , 2
)
)
),OrCAD
```

Figure B-18. Example netlist in the EEDesigner format.



**FutureNet  
(FUTURE.CF)**

The FutureNet system has two connectivity output formats: a netlist, and a pinlist. The netlist format lists each net in the schematic and the part pins that belong in that net. The pinlist format is a list of each pin on a part, and the net in which that pin belongs.

The FutureNet format can create both netlists and pinlists. By selecting the option:

- Create a netlist (instead of a pinlist)

a netlist is created instead of a pinlist. The two formats contain the same information, hence, neither has any inherent advantages over the other. You need to decide which format is best suited to your needs.

Another option available for the FutureNet format is:

- Do not append sheet number to label names

If this option is not selected, the FutureNet formatter adds an underscore ( \_ ) and the sheet number to any labels.

- ▲ **CAUTION:** *If you select this option, labels with the same name on different sheets are merged into one net. This option is typically selected only when the design consists of a single schematic sheet.*

The FutureNet formatter can also output pin numbers to the netlist or pinlist instead of pin names.

- Output pin numbers (instead of pin names)

Not all parts have both pin numbers and pin names defined. If the option is selected, and a pin without a number is found, then the pin name is used. If a netlist consisting entirely of pin numbers is desired, you may need to modify the OrCAD-supplied libraries, which is explained in the SPICE netlist section.

The FutureNet format also has several options for setting the attributes of parts in the netlist or pinlist. Normally, all module ports (input, output, and bidirectional) are assigned the attribute of 5 (signal name). The option:

- Create SIG\* attributes to module ports

substitutes the more precise attributes 10, 11, and 12 (input signal, output signal, and bidirectional signal, respectively) for the generic signal attribute 5.

Additionally, module ports can also have CON\* symbols created for them using the option:

- Create CON\* symbols for module ports

This option creates FutureNet SYMBol objects for the module ports. The new SYMBol objects (input, output, and bidirectional) are assigned the attributes 24, 25, and 26, respectively; and have the names CONI, CONO, and CONB, respectively, assigned in their data fields.

This option assigns FutureNet power attributes to **Schematic Design Tools** power objects:

- Assign FutureNet power attributes to power objects

When this option is selected, the pins on the following **Schematic Design Tools** power objects (which are matched by name) are assigned FutureNet power attributes.

| <b>OrCAD Pin Value</b> | <b>FutureNet Attribute</b> |
|------------------------|----------------------------|
| GND                    | 100                        |
| +5V                    | 101                        |
| +12V                   | 105                        |
| -12V                   | 106                        |
| VEE                    | 107                        |

The example pinlist in figure B-19 was created from the schematic in figure B-1 with no options selected.

```

PINLIST, 2
(DRAWING, ORCAD.PIN, 1-1
(SYM, 1
DATA, 2, U1
DATA, 3, 74LS00
DATA, 4, 14DIP300
PIN, ,Q_1, 1-1, 5, 23, IO_A
PIN, ,CLOCK, 1-1, 5, 23, I1_A
PIN, ,**000003, 1-1, 5, 21, O_A
PIN, ,B, 1-1, 5, 23, IO_B
PIN, ,**000003, 1-1, 5, 23, I1_B
PIN, ,Q_1, 1-1, 5, 21, O_B
PIN, ,GND, 1-1, 5, 23, GND
PIN, ,**000001, 1-1, 5, 21, O_C
PIN, ,A, 1-1, 5, 23, IO_C
PIN, ,A, 1-1, 5, 23, I1_C
PIN, ,UN000001, 1-1, 5, 21, O_D
PIN, ,UN000002, 1-1, 5, 23, IO_D
PIN, ,UN000003, 1-1, 5, 23, I1_D
PIN, ,VCC, 1-1, 5, 23, VCC
)
(SYM, 2
DATA, 2, U2
DATA, 3, 74LS32
DATA, 4, 14DIP300
PIN, ,**000001, 1-1, 5, 23, IO_A
PIN, ,Q_1, 1-1, 5, 23, I1_A
PIN, ,OUT, 1-1, 5, 21, O_A
PIN, ,UN000004, 1-1, 5, 23, IO_B
PIN, ,UN000005, 1-1, 5, 23, I1_B
PIN, ,UN000006, 1-1, 5, 21, O_B
PIN, ,GND, 1-1, 5, 23, GND
PIN, ,UN000007, 1-1, 5, 21, O_C
PIN, ,UN000008, 1-1, 5, 23, IO_C
PIN, ,UN000009, 1-1, 5, 23, I1_C
PIN, ,UN000010, 1-1, 5, 21, O_D
PIN, ,UN000011, 1-1, 5, 23, IO_D
PIN, ,UN000012, 1-1, 5, 23, I1_D
PIN, ,VCC, 1-1, 5, 23, VCC
)
SIG, Q_1, 1-1, 5, Q_1
SIG, VCC, 1-1, 5, VCC
SIG, A, 1-1, 5, A
SIG, GND, 1-1, 5, GND
SIG, B, 1-1, 5, B
SIG, OUT, 1-1, 5, OUT
SIG, CLOCK, 1-1, 5, CLOCK
)

```

Figure B-19. Example pinlist in the FutureNet netlist format.

The netlist in figure B-20 was created from the schematic in figure B-1 with the **Create a netlist (instead of a pinlist)** option selected.

```
NETLIST, 2
(DRAWING, ORCAD.NET, 1-1
DATA, 50, Generic Netlist Example
DATA, 51, OrCAD-01
DATA, 52, A
DATA, 54, October 30, 1990
)
(SYM, 1-1, 1
DATA, 2, U1
DATA, 3, 74LS00
DATA, 4, 14DIP300
DATA, 23, IO_A
DATA, 23, I1_A
DATA, 21, O_A
DATA, 23, IO_B
DATA, 23, I1_B
DATA, 21, O_B
DATA, 23, GND
DATA, 21, O_C
DATA, 23, IO_C
DATA, 23, I1_C
DATA, 21, O_D
DATA, 23, IO_D
DATA, 23, I1_D
DATA, 23, VCC
)
(SYM, 1-1, 2
DATA, 2, U2
DATA, 3, 74LS32
DATA, 4, 14DIP300
DATA, 23, IO_A
DATA, 23, I1_A
DATA, 21, O_A
DATA, 23, IO_B
DATA, 23, I1_B
DATA, 21, O_B
DATA, 23, GND
DATA, 21, O_C
DATA, 23, IO_C
DATA, 23, I1_C
DATA, 21, O_D
DATA, 23, IO_D
DATA, 23, I1_D
DATA, 23, VCC
)
)
```

Figure B-20. Example netlist in the FutureNet netlist format (continued).

```
(SIG,,***000001,1-1,5,***000001
PIN,1-1,1,U1,21,O_C
PIN,1-1,2,U2,23,IO_A
)
(SIG,,Q_1,1-1,5,Q_1
PIN,1-1,1,U1,21,O_B
PIN,1-1,2,U2,23,I1_A
|PIN,1-1,1,U1,23,IO_A
)
(SIG,,***000003,1-1,5,***000003
PIN,1-1,1,U1,23,I1_B
PIN,1-1,1,U1,21,O_A
)
(SIG,,VCC,1-1,5,VCC
PIN,1-1,2,U2,23,VCC
PIN,1-1,1,U1,23,VCC
)
(SIG,,A,1-1,5,A
PIN,1-1,1,U1,23,IO_C
PIN,1-1,1,U1,23,I1_C
)
(SIG,,GND,1-1,5,GND
PIN,1-1,2,U2,23,GND
PIN,1-1,1,U1,23,GND
)
(SIG,,B,1-1,5,B
PIN,1-1,1,U1,23,IO_B
)
(SIG,,OUT,1-1,5,OUT
PIN,1-1,2,U2,21,O_A
)
(SIG,,CLOCK,1-1,5,CLOCK
PIN,1-1,1,U1,23,I1_A
)
```

Figure B-20. Example netlist in the FutureNet netlist format.

**HiLo (HILO.CF)** The first option available for the HiLo format is:

- Do not append sheet number to labels

If this option is not selected, the HiLo formatter appends a dollar sign (\$) and the sheet number to any labels.

▲ **CAUTION:** *If you select this option, labels with the same name on different sheets are merged into one net. This option is typically selected only when the design consists of a single schematic sheet.*

The second option available for the HiLo format is:

- Include unconnected pins

If this option is selected, the HiLo formatter assigns all unconnected pins a unique net. If this option is not selected, the HiLo formatter assigns an unique net and reports an error.

The netlist in figure B-21 was created from the schematic in figure B-1 with no options selected.

```

** Generic Netlist Example           Revised:  October 30, 1990
** OrcAD-01                          Revision:  A
** OrcAD
** 3175 NW Aloclek Drive
** Hillsboro, OR 97124-7135
** (503) 690-9881 Sales & Administration
** (503) 690-9722 Technical Support
CCT ORCAD (
** Please put your circuit interface definition here
    );
14DIP300
U1 (
    QS1,
    CLOCK,
    N00003,
    B,
    N00003,
    QS1,
    GND,
    N00001,
    A,
    A,
    ,
    ,
    ,
    VCC
    );

14DIP300
U2 (
    N00001,
    QS1,
    OUT,
    ,
    ,
    ,
    GND,
    ,
    ,
    ,
    ,
    ,
    VCC
    );

```

Figure B-21. Example netlist in the HiLo format.



**IntelADF  
(INTELADF.CF)**

Three formatting options are available for the IntelADF format.

- Suppress comments

If this option is selected, the formatter won't put comments in the resulting netlist file. Comments in the IntelADF format are delimited by the percent (%) character.

- Do not append sheet number to labels

If this option is not selected, the IntelADF formatter appends a period (.) and the sheet number to any labels.

▲ **CAUTION:** *If you select this option, labels with the same name on different sheets are merged into one net. This option is typically selected only when the design consists of a single schematic sheet.*

- Include unconnected pins

If this option is selected, the IntelADF formatter assigns all unconnected pins a unique net. If this option is not selected, the IntelADF formatter assigns an unique net and reports an error.

*Title block*

Title block information is placed in the first 10 lines of the netlist. Table B-2 shows an example netlist header and the title block information from which the header was extracted. Header information in **bold** is text you enter in the schematic's title block.

| Line | Example Header               | Title Block Field |
|------|------------------------------|-------------------|
| 1    | <b>ADF Example</b>           | Title of sheet    |
| 1    | October 11, 1990             | Date              |
| 2    | <b>OrCAD-02</b>              | Document Number   |
| 2    | <b>A</b>                     | Revision Code     |
| 3    | <b>OrCAD</b>                 | Organization Name |
| 4    | <b>3175 NW Aloclek Drive</b> | 1st Address Line  |
| 6    | <b>Turbo = ON</b>            | 3rd Address Line  |
| 7    | <b>5C031</b>                 | 4th Address Line  |
| 9    | OPTIONS: <b>TURBO = ON</b>   |                   |
| 10   | PART: <b>5C031</b>           |                   |

Table B-2. Title block information in IntelADF netlists.

*Pipe commands* You can place equations in your schematic to be included in the netlist. To place these equations in your worksheet, use the **Draft's PLACE Text** command. You can also use a text editor to put the equations in an ASCII file, then use **Draft's BLOCK ASCII Import** command to import the contents of the file and place it on the worksheet.

Each equation must start with the *pipe* character (`|`). (On many PC keyboards, the pipe character appears as a broken vertical bar). The first line must be:

```
|EQUATIONS
```

This tells the formatter that some IntelADF equations need to be included in the netlist. The equations can contain any information you want to include in the netlist.

*Caveats* When you create an IntelADF netlist, you must configure **Schematic Design Tools** to use the OrCAD-supplied ADF.LIB library. You can only use the parts provided in the ADF library to create the schematic.

Inputs and outputs are handled differently in OrCAD's **Schematic Design Tools** and the Intel software. **Schematic Design Tools** defines inputs and outputs with module ports and an input/output library object. Intel defines inputs and outputs with a library object which is then tagged with the appropriate pin number. In figure B-2, the CLOCK signal is an input and the STROBE signal is an output.

Additionally, library objects with unused pins default to pre-defined levels in the Intel software. Because **Schematic Design Tools** does not default unconnected pins to any particular level, you must tie all unused pins to the appropriate level.

The netlist in figure B-22 was created from the schematic in figure B-2 with no options selected.

```

ADF Example                               Revised:  October 30, 1990
OrCAD-02                                 Revision:  A
OrCAD
3175 NW Aloclek Drive

TURBO = ON
5C031

OPTIONS:TURBO = ON
PART:5C031

INPUTS:
  ENABLE
  RESET
  COINDROP
  CUPFULL
  CLOCK

OUTPUTS:
  DROPCUP
  POURDRNK
  STROBE

NETWORK:
H.1=AND (F.1,E.1) % SYM 1 %
A.1=AND (B.1,C.1) % SYM 2 %
Q.1=AND (F.1,R.1) % SYM 3 %
G.1=AND (K.1,L.1,M.1) % SYM 4 %
P.1=AND (K.1,E.1,L.1) % SYM 5 %
STROBE=CONF (A.1,VCC) % SYM 6 %
M.1=INP (COINDROP) % SYM 7 %
D.1=INP (CLOCK) % SYM 8 %
N.1=INP (CUPFULL) % SYM 9 %
I.1=INP (RESET) % SYM 10 %
J.1=INP (ENABLE) % SYM 11 %
C.1=NOT (D.1) % SYM 12 %
L.1=NOT (N.1) % SYM 13 %
R.1=NOT (E.1) % SYM 14 %
K.1=NOT (F.1) % SYM 15 %
O.1=OR (P.1,Q.1) % SYM 16 %
DROPCUP,F.1=RORF (G.1,D.1,H.1,I.1,J.1) % SYM 17 %
POURDRNK,E.1=RORF (O.1,D.1,H.1,I.1,J.1) % SYM 18 %
B.1=XOR (E.1,F.1) % SYM 19 %

EQUATIONS:
G = (K & L & M);
H = (F & E);
O = (P # Q);
ENDS

```

Figure B-22. Example netlist in the IntelADF format.

**Intergraph  
(INTERGRA.CF)**

The only option available for the Intergraph format is:

- Do not append sheet number to labels

If this option is not selected, the Intergraph formatter appends a slash (/) and the sheet number to any labels.

▲ **CAUTION:** *If you select this option, labels with the same name on different sheets are merged into one net. This option is typically selected only when the design consists of a single schematic sheet.*

The netlist in figure B-23 was created from the schematic in figure B-1 with no options selected.

```

%PART
14DIP300      U1
14DIP300      U2
%NET
N00001          U1-8 U2-1
Q/1             U1-6 U2-2 U1-1
N00003          U1-5 U1-3
VCC             U2-14 U1-14
A               U1-9 U1-10
GND             U2-7 U1-7
B               U1-4
OUT             U2-3
CLOCK           U1-2
$
    
```

Figure B-23. Example netlist in the Intergraph format.

**Mentor (MENTOR.CF)** The only option available for the Mentor Board Station V6 format is:

- Do not append sheet number to labels

If this option is not selected, the Mentor formatter appends an underscore ( `_` ) and the sheet number to any labels.

▲ **CAUTION:** *If you select this option, labels with the same name on different sheets are merged into one net. This option is typically selected only when the design consists of a single schematic sheet.*

The Mentor formatter creates two files: a netlist file and a component file. A second filename must be entered in the "Destination 2" entry box for the formatter.

The netlist in figure B-24 and the corresponding component file in figure B-25 were created from the schematic in figure B-1 with no options selected.

```
NET 'N00001' U1-8 U2-1
NET 'Q_1' U1-6 U2-2 U1-1
NET 'N00003' U1-5 U1-3
NET 'VCC' U2-14 U1-14
NET 'A' U1-9 U1-10
NET 'GND' U2-7 U1-7
NET 'B' U1-4
NET 'OUT' U2-3
NET 'CLOCK' U1-2
```

Figure B-24. Example netlist in the Mentor format.

```
# OrCAD Formatted Netlist for MENTOR Board Station V6
# Reference      .... Value Field      Module Field
U1                PART 74LS00          14DIP300
U2                PART 74LS32          14DIP300
```

Figure B-25. Example component file in the Mentor format.

**MultiWire  
(MULTIWIR.CF)**

The only option available for the MultiWire format is:

- Do not append sheet number to labels

If this option is not selected, the MultiWire formatter appends a dash (-) and the sheet number to any labels.

▲ **CAUTION:** *If you select this option, labels with the same name on different sheets are merged into one net. This option is typically selected only when the design consists of a single schematic sheet.*

The netlist in figure B-26 was created from the schematic in figure B-1 with no options selected.

|        |    |    |
|--------|----|----|
| N00001 | U1 | 8  |
| N00001 | U2 | 1  |
| Q-1    | U1 | 6  |
| Q-1    | U2 | 2  |
| Q-1    | U1 | 1  |
| N00003 | U1 | 5  |
| N00003 | U1 | 3  |
| VCC    | U2 | 14 |
| VCC    | U1 | 14 |
| A      | U1 | 9  |
| A      | U1 | 10 |
| GND    | U2 | 7  |
| GND    | U1 | 7  |
| B      | U1 | 4  |
| OUT    | U2 | 3  |
| CLOCK  | U1 | 2  |
| -1     |    |    |

Figure B-26. Example netlist in the MultiWire format.

**OrCAD/PCB II  
(PCBII.CF)**

This netlist formatter provides backward compatibility to OrCAD/PCB II. **PC Board Layout Tools**, Release IV, uses the connectivity database directly, so no formatting is required. For more information on transferring to **PC Board Layout Tools**, see *Chapter 31: To Layout*, and the *PC Board Layout Tools User's Guide*.

The only option available for the OrCAD/PCB II format is:

- Do not append sheet number to labels

If this option is not selected, the OrCAD/PCB II formatter appends an underscore ( `_` ) and the sheet number to any labels.

▲ **CAUTION:** *If you select this option, labels with the same name on different sheets are merged into one net. This option is typically selected only when the design consists of a single schematic sheet.*

The netlist in figure B-27 was created from the schematic in figure B-1 with no options selected.

```
( { OrCAD/PCB II Netlist Format
Generic Netlist Example           Revised:  October 30, 1990
OrCAD-01                           Revision:  A
OrCAD
3175 NW Aloclek Drive
Hillsboro, OR 97124-7135
(503) 690-9881 Sales & Administration
(503) 690-9722 Technical Support }

( 6CB84CBA 14DIP300 U1 74LS00
( 1 Q_1 )
( 2 CLOCK )
( 3 N00003 )
( 4 B )
( 5 N00003 )
( 6 Q_1 )
( 7 GND )
( 8 N00001 )
( 9 A )
( 10 A )
( 11 21 )
```

Figure B-27. Example netlist in the OrCAD/PCB II format (continued).



```
( 12 ?2 )
( 13 ?3 )
( 14 VCC )
)
( 6E46169D 14DIP300 U2 74LS32
( 1 N00001 )
( 2 Q_1 )
( 3 OUT )
( 4 ?4 )
( 5 ?5 )
( 6 ?6 )
( 7 GND )
( 8 ?7 )
( 9 ?8 )
( 10 ?9 )
( 11 ?10 )
( 12 ?11 )
( 13 ?12 )
( 14 VCC )
)
)
```

Figure B-27. Example netlist in the OrCAD/PCB II format.

**OrCAD  
Programmable Logic  
Design Tools  
(PLDNET.CF)**

This netlist format is used only when defining **Programmable Logic Design Tools** logic graphically. See the *Programmable Logic Design Tools User's Guide* and the *Programmable Logic Design Tools Reference Guide* for details.

One option is available for the PLD Netlist format:

- Do not append sheet number to labels

If this option is not selected, the PLD Netlist formatter adds an underscore (\_) and the sheet number to any labels.

▲ **CAUTION:** *If you select this option, labels with the same name on different sheets are merged into one net. This option is typically selected only when the design consists of a single schematic sheet.*

*Caveats*

When you create a PLD netlist, you must configure **Schematic Design Tools** to use the OrCAD-supplied PLDGATES.LIB part library. You can only use the parts provided in PLDGATES.LIB to create the schematic.

The netlist in figure B-28 was created from the schematic in figure B-5.

```

|| PLD Netlist Example                Revised:  October 30, 1990
|| OrCAD-05                          Revision:  A
|| OrCAD
|| 3175 NW Aloclek Drive
|| Hillsboro, OR 97124-7135
|| (503) 690-9881 Sales & Administration
|| (503) 690-9722 Technical Support
||
|| Netlist:  BO,AO,A1,B1
||           ->
||           YO,Y1,Y2,Y3
||
|| {
|| G04 (AO,N00001) | U1
|| G04 (A1,N00004) | U2
|| G04 (BO,N00007) | U3
|| G04 (B1,N00010) | U4
|| G04 (AO,N00012) | U5
|| G04 (BO,N00014) | U6
|| G08 (BO,AO,YO) | U7
|| G11 (N00001,BO,-,-,-,-,-,-,-,-,N00002,A1) | U8
|| G11 (B1,N00004,-,-,-,-,-,-,-,-,N00005,AO) | U9
|| G11 (B1,N00007,-,-,-,-,-,-,-,-,N00008,AO) | U10
|| G11 (N00010,BO,-,-,-,-,-,-,-,-,N00009,A1) | U11
|| G11 (B1,A1,-,-,-,-,-,-,-,-,N00011,N00012) | U12
|| G11 (B1,N00014,-,-,-,-,-,-,-,-,N00013,A1) | U13
|| G21 (AO,A1,-,BO,B1,Y3) | U14
|| G32 (N00011,N00013,Y2) | U15
|| G32 (N00008,N00009,N00006) | U16
|| G32 (N00002,N00005,N00003) | U17
|| G32 (N00003,N00006,Y1) | U18
|| }

```

Figure B-28. Example netlist in the PLD Netlist format.

**OrCAD Digital  
Simulation Tools  
Model  
(VSTMODEL.CF)**

This netlist format is used only when compiling **Digital Simulation Tools** simulation models. See the *Digital Simulation Tools User's Guide* for details.

One option is available for the VSTModel netlist.

- Suppress comments in the netlist file

If this option is selected, the formatter won't put comments in the resulting netlist file. Comments in the VSTModel format begin with a semicolon(;).

*Pipe commands*

Lines of text may be placed in your schematic, to be included in the VSTModel netlist. Use **Draft's PLACE Text** command to place the text in your schematic, or use an editor to put the text in a text file, then use **Draft's BLOCK ASCII Import** command to import the contents of the file and place it on the worksheet.

Each line of text must start with the *pipe* character (|). (On many PC keyboards, the pipe character displays as a broken vertical bar.) The first line must be:

```
|VST_MODEL
```

This tells the formatter to extract the information in the following lines of text when generating a VSTModel netlist. The remaining lines can contain a header, comments, and directives compatible with OrCAD's **Digital Simulation Tools Add Device Model** device modeling language. For details on the **Add Device Model Language**, see the *Digital Simulation Tools User's Guide*.

*Caveats*

When you create a VSTModel netlist, you must have **Schematic Design Tools** configured to use the OrCAD-supplied VSTGATES.LIB, VSTRAM.LIB, VSTROM.LIB, and VSTOTHER.LIB part libraries. You can only use the parts provided in these libraries to create the schematic.

The netlist in figure B-29 was created from the schematic in figure B-3 with no options selected.

```
;  
;2 TO 1 MULTIPLEXOR  
;  
:21MUX MY_LIB 4  
LINV (P3;L1);M1  
LAND (P2,P1;L2);M2  
LNOR (L1,P1;L3);M3  
SET (RHIGH)  
OR (L2,L3;P4;10,50,15,50);M4  
%
```

Figure B-29. Example netlist in the VSTModel format.

**PADS ASCII  
(PADSASC.CF)**

The only option available for the PADS ASCII format is:

- Do not append sheet number to labels

If this option is not selected, the PADS ASCII formatter appends a dash (-) and the sheet number to any labels.

▲ **CAUTION:** *If you select this option, labels with the same name on different sheets are merged into one net. This option is typically selected only when the design consists of a single schematic sheet.*

In addition to the connection list file, the PADS ASCII formatter also creates a part list file. A second filename must be entered in the Destination 2 entry box for the formatter.

The netlist in figure B-30 and the corresponding component file in figure B-31 were created from the schematic in figure B-1 with no options selected.

```
*PADS-PCB
*Net
*Sig N1
U1.8 U2.1
*Sig Q-1
U1.6 U2.2 U1.1
*Sig N00003
U1.5 U1.3
*Sig VCC
U2.14 U1.14
*Sig A
U1.9 U1.10
*Sig GND
U2.7 U1.7
*Sig B
U1.4
*Sig OUT
U2.3
*Sig CLOCK
U1.2
*End
```

Figure B-30. Example connection list in the PADS ASCII format.

```
*PADS-PCB
*Part*
U1      14DIP300
U2      14DIP300
*End
```

*Figure B-31. Example part list in the PADS ASCII format.*

**PCAD (PCAD.CF)**

The first option available for the PCAD format is:

- Do not append sheet number to labels

If this option is not selected, the PCAD formatter appends an underscore (\_) and the sheet number to any labels.

- ▲ **CAUTION:** *If you select this option, labels with the same name on different sheets are merged into one net. This option is typically selected only when the design consists of a single schematic sheet.*

The second option available for the PCAD format is:

- Include unconnected pins

If this option is selected, the PCAD formatter assigns all unconnected pins a unique net. If this option is not selected, the PCAD formatter assigns an unique net and reports an error.

The netlist in figure B-32 was created from the schematic in figure B-1 with no options selected.



```

{COMPONENT ORCAD.PCB
{ENVIRONMENT
  {PDIFrev 1.30}
  {Program "PC-CARDS Version 0.02"}
  {DBtype "PC-Board"}
  {DBrev 1.0}
  {DBunit "MIL"}
  {DBgrid 1}
  {lyrstr "PADCOM" 7 "FLCOMP" 7 "PADSLD" 8
    "FLSOLD" 8 "PADINT" 9
    "FLINT" 9 "GNDCOM" 10 "FLGCON" 10
    "GNDCLR" 12 "FLGCLR" 12
    "PWRCCLR" 13 "FLPCLR" 13 "SLDMSK" 14
    "FLSMSK" 14 "DRILL" 15
    "FLDRLL" 15 "PIN" 4 "BRDOUT" 4 "FLTARG" 4
    "SLKSCR" 6
    "DEVICE" 5 "ATTR" 6 "REFDES" 6 "COMP" 1
    "SOLDER" 2 "INT1" 3
  }
}
{USER
  {PCAD
    {Vw 750 350 8}
    {Lv 24 1 0 0 0 0 0 0 0 0 0 0 0 0 0 0 1 1 0 1 1 0 0 2 2 0}
    {Gs 50 50}
  }
}
{DISPLAY
  [Ly "COMP"]
  [Ls "SOLID"] [Wd 15]
  [Ts 125] [Tj "CC"] [Tr 1] [Tm "N"]
}
{SYMBOL
  {PIN_DEF
  }
}

```

Figure B-32. Example netlist in the PCAD format (continued).

```

{PIC
}
{ATR
{IN
  {Org -32767 -32767}
  {Ty 255}
}
}
{DETAIL
}
{NET_DEF
}
{PAD_STACK
}
{SUBCOMP
{I 14DIP300.PRT U1
{CN
  1 Q_1
  2 CLOCK
  3 NET00003
  4 B
  5 NET00003
  6 Q_1
  7 GND
  8 NET00001
  9 A
  10 A
  11 ?
  12 ?
  13 ?
  14 VCC
}
}
{I 14DIP300.PRT U2
{CN
  1 NET00001
  2 Q_1
  3 OUT
  4 ?
  5 ?
  6 ?
  7 GND
  8 ?
  9 ?
  10 ?
  11 ?
  12 ?
  13 ?
  14 VCC
}
}
}
}
}
}
}

```

Figure B-32. Example netlist in the PCAD format.

**PCADnlt  
(PCADNLT.CF)**

The only option available for the PCADnlt format is:

- Do not append sheet number to labels

If this option is not selected, the PCADnlt formatter adds an underscore ( `_` ) and the sheet number to any labels.

▲ **CAUTION:** *If you select this option, labels with the same name on different sheets are merged into one net. This option is typically selected only when the design consists of a single schematic sheet.*

The netlist in figure B-33 was created from the schematic in figure B-1 with no options selected.

```

% Generic Netlist Example                Revised:  October 30, 1990
% OrCAD-01                               Revision:  A
% OrCAD
% 3175 NW Aloclek Drive
% Hillsboro, OR 97124-7135
% (503) 690-9881 Sales & Administration
% (503) 690-9722 Technical Support
BOARD = ORCAD.PCB;

PARTS
14DIP300      = U1,  % 74LS00
                U2;  % 74LS32

NETS

N00001      = U1/8 U2/1 ;
Q_1         = U1/6 U2/2 U1/1 ;
N00003      = U1/5 U1/3 ;
VCC         = U2/14 U1/14 ;
A           = U1/9 U1/10 ;
GND         = U2/7 U1/7 ;
B           = U1/4 ;
OUT         = U2/3 ;
CLOCK       = U1/2 ;
    
```

Figure B-33. Example netlist in the PCADnlt format.

**RacalRedac  
(RACALRED.CF)**

The only option available for the RacalRedac format is:

- Do not append sheet number to labels

If this option is not selected, the RacalRedac formatter adds an underscore ( \_ ) and the sheet number to any labels.

▲ **CAUTION:** *If you select this option, labels with the same name on different sheets are merged into one net. This option is typically selected only when the design consists of a single schematic sheet.*

The RacalRedac formatter creates two files. In addition to the netlist file, it also creates a component file. A second filename must be entered in the **Destination 2** entry box for the formatter.

The netlist in figure B-34 and the corresponding component file in figure B-35 were created from the schematic in figure B-1 with no options selected.

```
.PCB
.REM Generic Netlist Example           Revised:  October 30, 1990
.REM OrCAD-01                         Revision:  A
.REM OrCAD
.REM 3175 NW Aloclek Drive
.REM Hillsboro, OR 97124-7135
.REM (503) 690-9881 Sales & Administration
.REM (503) 690-9722 Technical Support
.CON
.COD 2

.REM N00001
U1 8 U2 1
.REM Q_1 (local to sheet 1)
U1 6 U2 2 U1 1
.REM N00003
U1 5 U1 3
.REM VCC
U2 14 U1 14
.REM A
U1 9 U1 10
.REM GND
U2 7 U1 7
.REM B
U1 4
.REM OUT
```

Figure B-34. Example netlist in the RacalRedac format.

```
U2 3
.REM CLOCK
U1 2
.EOD
.PCB
.REM Generic Netlist Example           Revised:  October 30, 1990
.REM OrCAD-01                         Revision:  A
.REM OrCAD
.REM 3175 NW Aloclek Drive
.REM Hillsboro, OR 97124-7135
.REM (503) 690-9881 Sales & Administration
.REM (503) 690-9722 Technical Support
.REF

.REM 74LS00
U1 14DIP300
.REM 74LS32
U2 14DIP300
.EOD
```

Figure B-35. Example component list in the RacalRedac format.

**Scicards  
(SCICARDS.CF)**

The only option available for the Scicards format is:

- Do not append sheet number to labels

If this option is not selected, the Scicards formatter appends a dash (-) and the sheet number to any labels.



**CAUTION:** If you select this option, labels with the same name on different sheets are merged into one net. This option is typically selected only when the design consists of a single schematic sheet.

The netlist in figure B-36 was created from the schematic in figure B-1 with no options selected.

```

PARTS LIST
74LS00          14DIP300      U1
74LS32          14DIP300      U2
EOS
NET LIST
NODE      1                $
  U1      8  U2            1
NODENAME Q-1                $
  U1      6  U2            2  U1      1
NODE      3                $
  U1      5  U1            3
NODENAME VCC                $
  U2     14  U1           14
NODENAME A                  $
  U1      9  U1           10
NODENAME GND                $
  U2      7  U1            7
NODENAME B                  $
  U1      4
NODENAME OUT                $
  U2      3
NODENAME CLOCK              $
  U1      2
EOS
    
```

Figure B-36. Example netlist in the Scicards format.

**SPICE (SPICE.CF)** This is one of two SPICE formatters supplied with OrCAD's **Schematic Design Tools**. This formatter can only be used to create flat SPICE netlists. The hierarchical SPICE formatter is discussed in the next section.

The first option available for the SPICE format is:

- Do not append sheet number to labels

If this option is not selected, the SPICE formatter appends an underscore (\_) and the sheet number to any labels.

▲ **CAUTION:** *If you select this option, labels with the same name on different sheets are merged into one net. This option is typically selected only when the design consists of a single schematic sheet.*

The second available option is:

- Include unconnected pins

If this option is selected, the SPICE formatter assigns all unconnected pins a unique net. If this option is not selected, the SPICE formatter assigns an unique net and reports an error.

The third available option is:

- Use node names

If this option is selected, the SPICE formatter uses the node names you have placed on the schematic (via labels and module ports) where available. Not all versions of SPICE support alphanumeric node names, check your SPICE manual. If your version of SPICE does not allow alphanumeric node names, you can still give them numeric names (such as '17'). These numeric names will not interfere with the ones generated by the SPICE formatter, since formatter generated node numbers begin at 10000 (except GND, which is always 0).

*Pipe commands* You can place lines of text in your schematic, to be included in the SPICE netlist. Use **Draft**'s **PLACE Text** command to place the text in your schematic, or use an editor to put the text in an ASCII file, then use **Draft**'s **BLOCK ASCII Import** command to import the contents of the file and place it on the worksheet.

Each line of text must start with the *pipe* character (`|`). (On many PC keyboards, the pipe character appears as a broken vertical bar.) The first line must be:

```
|SPICE
```

This tells the formatter to extract the information in the following lines of text when generating a SPICE netlist. The remaining lines can contain any information you want to include in the netlist. The lines following `|SPICE` are placed at the top of the netlist.

*Caveats* **Schematic Design Tools** can create netlists larger than most PC-based SPICE programs accept. Consult your SPICE manual for the limits. If your PC meets SPICE's memory requirements, you can generate the largest netlist allowed.

The part value is used to pass modeling information to the netlist. For instance, resistor RS1 in figure B-4 has a value of 1K Ohms.

Use the special PSPICE.LIB or SPICE.LIB libraries supplied by OrCAD when generating a SPICE netlist. These libraries already have pin numbers on the parts and are compatible with most versions of SPICE. The PSPICE.LIB contains many specific part types, such as a 2N2222 NPN transistor, that are not provided in the generic SPICE.LIB.

To modify or create your own SPICE library, you must support the proper model pin numbers. To implement this, use the **Decompile Library** or **Edit Library** librarians and convert the desired OrCAD-supplied libraries into a library source file. Make the appropriate changes to the source file and recompile the modified library back to an object file using the **Edit Library** button.



All library part pin names should be changed to reflect the model node index. To find out the proper node ordering, see your SPICE manual.

As an example of what to change, the OrCAD-supplied NPN transistor has the pin names defined as base, emitter, and collector in the DEVICE.LIB library. For SPICE to understand the nodal information, the pin names must be changed from base, emitter, and collector to 2, 3, and 1 (as defined in the SPICE manual). Therefore, the library source file for an NPN transistor that is compatible with the SPICE pin numbering convention is as follows:

```
'NPN'
REFERENCE 'Q'
{X Size =} 2 {Y Size =} 2 {Parts per Package =} 0
L1 SHORT IN '2'
B2 SHORT IN '3'
T2 SHORT IN '1'
{ 0}.....##.....#
{ 1}      ##      #
      .
      .
      .
```

Figure B-37. Library source file for the NPN transistor.

The SPICE formatter creates two files. In addition to the netlist file, it also creates a map file. The node numbers created by the formatter are placed in the .MAP file so you may cross reference the SPICE node numbers with the node names that you have specified in your schematic. The filename for this map file must be entered in the **Destination 2** entry box for the formatter.

The netlist in figure B-38 and the corresponding map file in figure B-39 were created from the schematic in figure B-4 with no options selected.

```

* SPICE Example                      Revised:  October 30, 1990
* OrCAD-04                          Revision:  A
* OrCAD
* 3175 NW Alcolek Drive
* Hillsboro, OR 97124-7135
* (503) 690-9881 Sales & Administration
* (503) 690-9722 Technical Support
.OPTIONS ACCT LIST NODE OPTS NOPAGE RELTOL=.001
.WIDTH OUT=80
.DC VIN -0.25 0.25 0.005
.AC DEC 10 1 10GHZ
.TRAN/OP 5NS 500NS
.MODEL QNL NPN (BF=80 RB=100 CJS=2PF
+   TF=0.3NS TR=6NS VAF=50)
.PRINT DC V(4) V(5)
.PLOT DC IC(Q2)
.PROBE
VCC 10007 0 DC 12
VIN 10008 0 AC 1 SIN(0 0.1 5MEG)
VEE 10010 0 DC -12
RC1 10007 10001 10K
RC2 10007 10002 10K
RS1 10004 0 1K
RS2 10008 10003 1K
RBIAS1 10007 10006 20K
CLOAD1 10001 10002 5PF
Q1 10005 10006 10010 QNL
Q2 10001 10003 10005 QNL
Q3 10002 10004 10005 QNL
Q4 10006 10006 10010 QNL
.END

```

Figure B-38. Example netlist in the SPICE format.

```

10001 4
10002 5
10005 6
10006 7
10007 VCC DC 12
10008 VIN AC 1 SIN(0 0.1 5MEG)
      0 GND
10010 VEE DC -12

```

Figure B-39. Example map file in the SPICE format.

**Tango (TANGO.CF)** The only option available for the Tango format is:

- Do not append sheet number to labels

If this option is not selected, the Tango formatter appends a dash (-) and the sheet number to any labels.

▲ **CAUTION:** *If you select this option, labels with the same name on different sheets are merged into one net. This option is typically selected only when the design consists of a single schematic sheet.*

The netlist in figure B-40 was created from the schematic in figure B-1 with no options selected.

```
Generic Netlist Example          Revised:  October 30, 1990
OrCAD-01                         Revision:  A
OrCAD
3175 NW Aloclek Drive
Hillsboro, OR  97124-7135
(503) 690-9881 Sales & Administration
(503) 690-9722 Technical Support

[
U1
14DIP300
74LS00

]

[
U2
14DIP300
74LS32

]

(
N00001
U1,8
U2,1
)

(
Q-1
U1,6
U2,2
U1,1
```

Figure B-40. Example netlist in the Tango format (continued).

```
)  
(  
N00003  
U1,5  
U1,3  
)  
(  
VCC  
U2,14  
U1,14  
)  
(  
A  
U1,9  
U1,10  
)  
(  
GND  
U2,7  
U1,7  
)  
(  
B  
U1,4  
)  
(  
OUT  
U2,3  
)  
(  
CLOCK  
U1,2  
)  
)
```

Figure B-40. Example netlist in the Tango format.

**Telesis  
(TELESIS.CF)**

The only option available for the Telesis format is:

- Do not append sheet number to labels

If this option is not selected, the Telesis formatter appends a slash (/) and the sheet number to any labels.

▲ **CAUTION:** *If you select this option, labels with the same name on different sheets are merged into one net. This option is typically selected only when the design consists of a single schematic sheet.*

The netlist in figure B-41 was created from the schematic in figure B-1 with no options selected.

```
SPACKAGES
14DIP300! 74LS00; U1
14DIP300! 74LS32; U2
$NETS
N00001; U1.8 U2.1
Q/1; U1.6 U2.2 U1.1
N00003; U1.5 U1.3
VCC; U2.14 U1.14
A; U1.9 U1.10
GND; U2.7 U1.7
B; U1.4
OUT; U2.3
CLOCK; U1.2
$END
```

Figure B-41. Example netlist in the Telesis format.

**Vectron  
(VECTRON.CF)**

The only option available for the Vectron format is:

- Do not append sheet number to labels

If this option is not selected, the Vectron formatter appends a period (.) and the sheet number to any labels.

▲ **CAUTION:** *If you select this option, labels with the same name on different sheets are merged into one net. This option is typically selected only when the design consists of a single schematic sheet.*

The Vectron formatter creates two files. In addition to the netlist file, it also creates a part list file. A second filename must be entered in the "Destination 2" entry box for the formatter.

The netlist in figure B-42 and the corresponding part file in figure B-43 were created from the schematic in figure B-1 with no options selected.

```
*N00001      U1 8 U2 1
*Q.1         U1 6 U2 2 U1 1
*N00003      U1 5 U1 3
*VCC         U2 14 U1 14
*A           U1 9 U1 10
*GND         U2 7 U1 7
*B           U1 4
*OUT         U2 3
*CLOCK       U1 2
```

Figure B-42. Example netlist in the Vectron format.

```
U1      14DIP300
U2      14DIP300
```

Figure B-43. Example part list file in the Vectron format.

**WireList** Three options are available for the WireList format is:

- Do not append sheet number to labels

If this option is not selected, the WireList formatter appends an underscore ( \_ ) and the sheet number to any labels.

▲ **CAUTION:** *If you select this option, labels with the same name on different sheets are merged into one net. This option is typically selected only when the design consists of a single schematic sheet.*

- Do not output pin numbers for Grid Array parts

When this option is not selected, the WireList format does not output pin numbers for grid array parts.

- Abbreviate label descriptions

If this option is selected, the WireList format shortens label descriptions.

The netlist in figure B-44 was created from the schematic in figure B-1 with no options selected.



```

Wire List

Generic Netlist Example                Revised:  October 30, 1990
OrCAD-01                               Revision:  A
OrCAD
3175 NW Aloclek Drive
Hillsboro, OR 97124-7135
(503) 690-9881 Sales & Administration
(503) 690-9722 Technical Support

<<< Component List >>>
74LS00                                U1      14DIP300
74LS32                                U2      14DIP300

<<< Wire List >>>

  NODE  REFERENCE  PIN #  PIN NAME      PIN TYPE  PART VALUE
[00001] N00001
        U1         8      O_C           Output    74LS00
        U2         1      IO_A          Input     74LS32
[00002] Q_1 (local to sheet 1)
        U1         6      O_B           Output    74LS00
        U2         2      I1_A          Input     74LS32
        U1         1      IO_A          Input     74LS00
[00003] N00003
        U1         5      I1_B          Input     74LS00
        U1         3      O_A           Output    74LS00
[00004] VCC
        U2         14     VCC           Power     74LS32
        U1         14     VCC           Power     74LS00

```

Figure B-44. Example netlist in the WireList format (continued).

|         |       |    |      |        |               |
|---------|-------|----|------|--------|---------------|
| [00005] | A     |    |      |        |               |
|         | U1    | 9  | I0_C | Input  | <b>74LS00</b> |
|         | U1    | 10 | I1_C | Input  | <b>74LS00</b> |
| [00006] | GND   |    |      |        |               |
|         | U2    | 7  | GND  | Power  | <b>74LS32</b> |
|         | U1    | 7  | GND  | Power  | <b>74LS00</b> |
| [00007] | B     |    |      |        |               |
|         | U1    | 4  | I0_B | Input  | <b>74LS00</b> |
| [00008] | OUT   |    |      |        |               |
|         | U2    | 3  | O_A  | Output | <b>74LS32</b> |
| [00009] | CLOCK |    |      |        |               |
|         | U1    | 2  | I1_A | Input  | <b>74LS00</b> |

Figure B-44. Example netlist in the WireList format.

## **Hierarchical netlists**

In order to create a netlist in one of the hierarchical formats, your schematic must have been processed by INET (linking is not necessary). The necessary steps are explained in *Chapter 11: Create Hierarchical Netlist*.

Hierarchical netlist formatter files are distinguished by a .CH file extension. They cannot be used within the **Create Netlist** processor (the two interpreter formats are similar; but process incompatible data structures).

Each of the formatters can create formatted netlists that contain either simple or complex hierarchies.

### **Example Schematics**

The two schematics shown in figures B-45 and B-46 are used by the hierarchical EDIF and SPICE netlists.

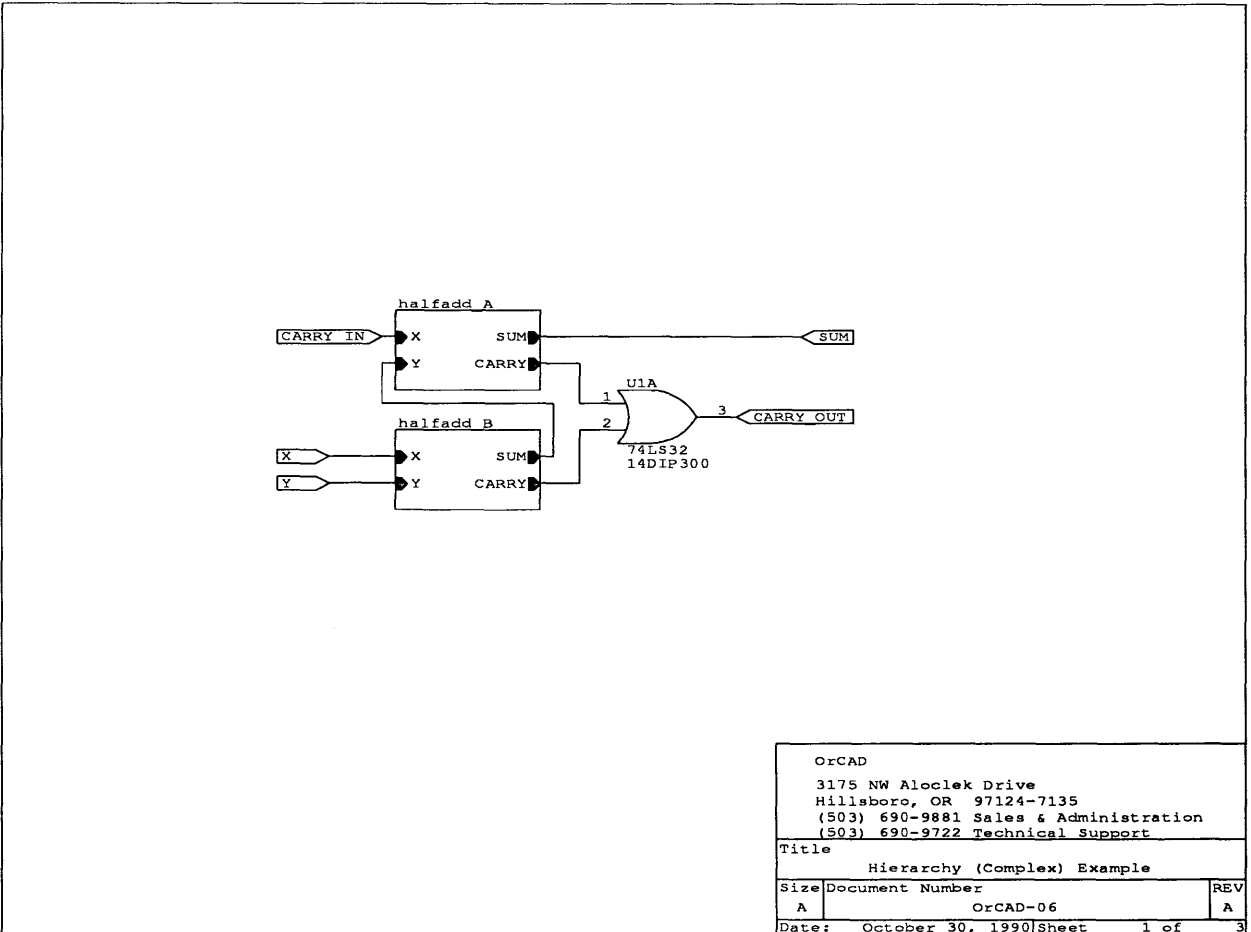
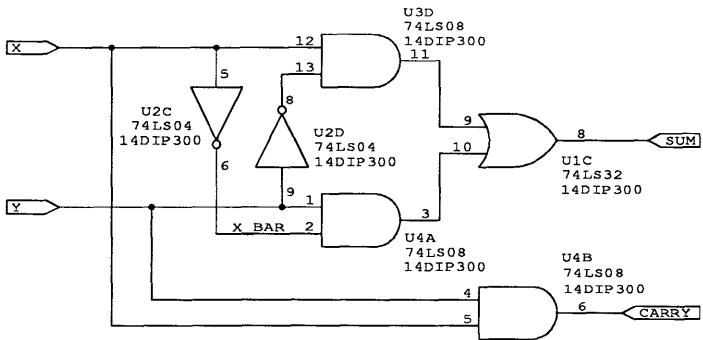

Figure B-45. Root sheet used by the hierarchical EDIF format.



|  |                  |              |
|--|------------------|--------------|
| OrCAD  |                  |              |
| 3175 NW Aloclek Drive<br>Hillsboro, OR 97124-7135<br>(503) 690-9881 Sales & Administration<br>(503) 690-9722 Technical Support |                  |              |
| Title  |                  |              |
| Half Adder   |                  |              |
| Size   | Document Number  | REV          |
| A  | OrCAD-06b        | A            |
| Date:  | October 30, 1990 | Sheet 3 of 3 |

Figure B-46. Leaf sheet used by the hierarchical EDIF format.

Figure B-47. Root sheet used by the hierarchical SPICE format (continued).

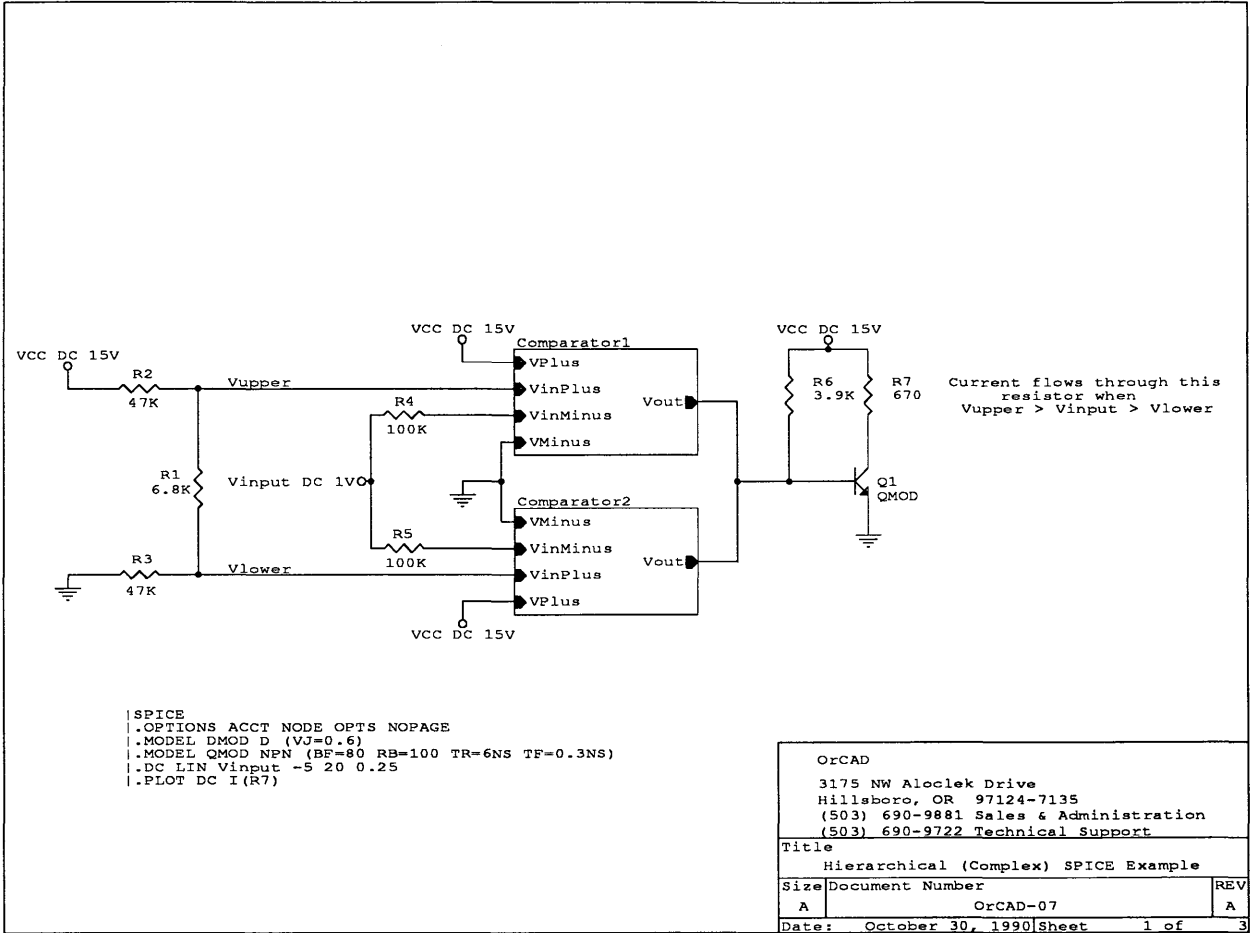

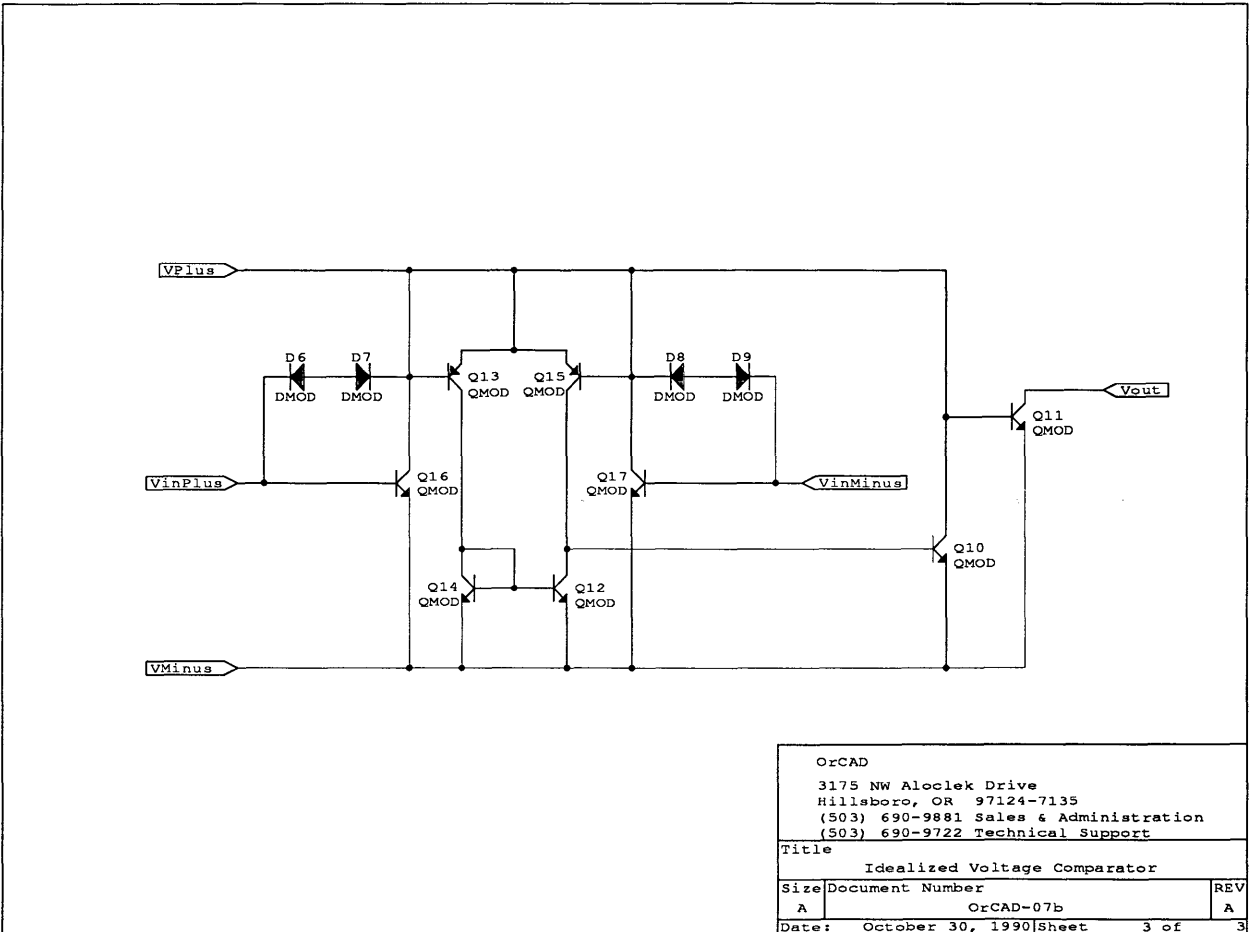

Figure B-48. Leaf sheet used by the hierarchical SPICE format.

**EDIF (EDIF.CH)** This is one of two EDIF (Version 2 0 0) formatters supplied with OrCAD's **Schematic Design Tools**. This formatter can only be used to create hierarchical EDIF netlists. The flat EDIF formatter was discussed in the previous section. All of the options that apply to the flat EDIF format apply to the hierarchical version as well. The first option available for the EDIF format is:

- Do not append sheet number to labels

If this option is not selected, the EDIF formatter appends an underscore (\_) and the sheet number to any labels.

▲ **CAUTION:** *If you select this option, labels with the same name on different sheets are merged into one net. This option is typically selected only when the design consists of a single schematic sheet.*

The EDIF formatter can also output pin numbers to the netlist instead of pin names.

- Output pin numbers (instead of pin names)

Not all parts have both pin names and pin numbers defined. If this option is selected, and a pin without a number is found, the pin name is used. If a netlist consisting entirely of pin numbers is required, you may need to modify the library part.

The hierarchical EDIF formatter manages the hierarchy by turning sheets in the schematic into CELLS in the main LIBRARY. These cells can then be referred to by INSTANCE where needed. Because EDIF requires a define-before-use philosophy, the hierarchy appears to be inverted in the netlist (the root sheet is the last CELL in the main LIBRARY).

The netlist in figure B-49 was created from the schematic in figure B-44 with no options selected.



```

(edif &EX6
(edifVersion 2 0 0)
(edifLevel 0)
(keywordMap (keywordLevel 0))
(status
(written
(timeStamp 0 0 0 0 0 0)
(program "HFORM.EXE")
(comment "Original data from OrCAD/SDT schematic"))
(comment "Hierarchy (Complex) Example")
(comment " November 7, 1990")
(comment "OrCAD-06")
(comment "A")
(comment "OrCAD")
(comment "3175 NW Aloclek Drive")
(comment "Hillsboro, OR 97124-7135")
(comment "(503) 690-9881 Sales & Administration")
(comment "(503) 690-9722 Technical Support"))
(external OrCAD_LIB
(edifLevel 0)
(technology
(numberDefinition
(scale 1 1 (unit distance))))
(cell &74LS04
(cellType generic)
(comment "From OrCAD library TTL.LIB")
(view NetlistView
(viewType netlist)
(interface
(port &I_A (direction INPUT))
(port &I_B (direction INPUT))
(port &I_C (direction INPUT))
(port &I_D (direction INPUT))
(port &I_E (direction INPUT))
(port &I_F (direction INPUT))
(port &O_A (direction OUTPUT))
(port &O_B (direction OUTPUT))
(port &O_C (direction OUTPUT))
(port &O_D (direction OUTPUT))
(port &O_E (direction OUTPUT))
(port &O_F (direction OUTPUT))
(port &VCC (direction INPUT))
(port &GND (direction INPUT))))))
(cell &74LS08
(cellType generic)
(comment "From OrCAD library TTL.LIB")
(view NetlistView
(viewType netlist)
(interface
(port &IO_A (direction INPUT))
(port &IO_B (direction INPUT))
(port &IO_C (direction INPUT))
(port &IO_D (direction INPUT))
(port &I1_A (direction INPUT))
(port &I1_B (direction INPUT))
(port &I1_C (direction INPUT))
(port &I1_D (direction INPUT))
(port &O_A (direction OUTPUT))
(port &O_B (direction OUTPUT))

```

Figure B-49. Example netlist in the hierarchical EDIF format (continued).

```

(port &O_C (direction OUTPUT))
(port &O_D (direction OUTPUT))
(port &VCC (direction INPUT))
(port &GND (direction INPUT))))
(cell &74LS32
(cellType generic)
(comment "From OrCAD library TTL.LIB")
(view NetlistView
(viewType netlist)
(interface
(port &IO_A (direction INPUT))
(port &IO_B (direction INPUT))
(port &IO_C (direction INPUT))
(port &IO_D (direction INPUT))
(port &I1_A (direction INPUT))
(port &I1_B (direction INPUT))
(port &I1_C (direction INPUT))
(port &I1_D (direction INPUT))
(port &O_A (direction OUTPUT))
(port &O_B (direction OUTPUT))
(port &O_C (direction OUTPUT))
(port &O_D (direction OUTPUT))
(port &VCC (direction INPUT))
(port &GND (direction INPUT))))))
(library MAIN_LIB
(edifLevel 0)
(technology
(numberDefinition
(scale 1 1 (unit distance))))
(cell &EX6B
(cellType generic)
(view NetlistView
(viewType netlist)
(interface
(port &CARRY (direction OUTPUT))
(port &SUM (direction OUTPUT))
(port &X (direction INPUT))
(port &Y (direction INPUT)))
(contents
(instance &U2
(viewRef NetlistView
(cellRef &74LS04
(libraryRef OrCAD_LIB)))
(property PartValue (string "74LS04"))
(property ModuleValue (string "14DIP300")))
(instance &U3
(viewRef NetlistView
(cellRef &74LS08
(libraryRef OrCAD_LIB)))
(property PartValue (string "74LS08"))
(property ModuleValue (string "14DIP300")))
(instance &U4
(viewRef NetlistView
(cellRef &74LS08
(libraryRef OrCAD_LIB)))
(property PartValue (string "74LS08"))
(property ModuleValue (string "14DIP300")))
(instance &U1

```

Figure B-49. Example netlist in the hierarchical EDIF format (continued).

```

(viewRef NetlistView
  (cellRef &74LS32
    (libraryRef OrCAD_LIB)))
(property PartValue (string "74LS32"))
(property ModuleValue (string "14DIP300"))
(net &VCC
  (joined
    (portRef &VCC (instanceRef &U4))
    (portRef &VCC (instanceRef &U1))
    (portRef &VCC (instanceRef &U2))
    (portRef &VCC (instanceRef &U3))))
(net &X
  (joined
    (portRef &X)
    (portRef &I1B (instanceRef &U4))
    (portRef &IC (instanceRef &U2))
    (portRef &IOD (instanceRef &U3))))
(net N00013
  (joined
    (portRef &OD (instanceRef &U3))
    (portRef &IOC (instanceRef &U1))))
(net N00014
  (joined
    (portRef &OD (instanceRef &U2))
    (portRef &I1D (instanceRef &U3))))
(net &GND
  (joined
    (portRef &GND (instanceRef &U4))
    (portRef &GND (instanceRef &U1))
    (portRef &GND (instanceRef &U3))
    (portRef &GND (instanceRef &U2))))
(net &SUM
  (joined
    (portRef &SUM)
    (portRef &OC (instanceRef &U1))))
(net N00017
  (joined
    (portRef &I1C (instanceRef &U1))
    (portRef &OA (instanceRef &U4))))
(net &X_BAR_3
  (joined
    (portRef &OC (instanceRef &U2))
    (portRef &I1A (instanceRef &U4))))
(net &Y
  (joined
    (portRef &Y)
    (portRef &IOB (instanceRef &U4))
    (portRef &ID (instanceRef &U2))
    (portRef &IOA (instanceRef &U4))))
(net &CARRY
  (joined
    (portRef &CARRY)
    (portRef &OB (instanceRef &U4))))))
(cell &EX6
  (cellType generic)
  (view NetlistView
    (viewType netlist)
    (interface

```

Figure B-49. Example netlist in the hierarchical EDIF format (continued).

```

(port &CARRY_IN (direction INPUT))
(port &CARRY_OUT (direction OUTPUT))
(port &SUM (direction OUTPUT))
(port &X (direction INPUT))
(port &Y (direction INPUT))
(contents
(instance &U1
(viewRef NetlistView
(cellRef &74LS32
(libraryRef OrCAD_LIB)))
(property PartValue (string "74LS32"))
(property ModuleValue (string "14DIP300")))
(instance &halfadd A
(viewRef NetlistView
(cellRef &EX6B)))
(instance &halfadd B
(viewRef NetlistView
(cellRef &EX6B)))
(net &CARRY_IN
(joined
(portRef &CARRY_IN)
(portRef &X (instanceRef &halfadd_A))))
(net &SUM
(joined
(portRef &SUM)
(portRef &SUM (instanceRef &halfadd_A))))
(net N00023
(joined
(portRef &Y (instanceRef &halfadd_A))
(portRef &SUM (instanceRef &halfadd_B))))
(net N00024
(joined
(portRef &CARRY (instanceRef &halfadd_A))
(portRef &IOA (instanceRef &U1))))
(net &VCC
(joined
(portRef &VCC (instanceRef &U1))))
(net &CARRY_OUT
(joined
(portRef &CARRY_OUT)
(portRef &OA (instanceRef &U1))))
(net N00027
(joined
(portRef &I1A (instanceRef &U1))
(portRef &CARRY (instanceRef &halfadd_B))))
(net &GND
(joined
(portRef &GND (instanceRef &U1))))
(net &X
(joined
(portRef &X)
(portRef &X (instanceRef &halfadd_B))))
(net &Y
(joined
(portRef &Y)
(portRef &Y (instanceRef &halfadd_B))))))
(design &EX6
(cellRef &EX6
(libraryRef MAIN_LIB)))

```

Figure B-49. Example netlist in the hierarchical EDIF format.

**SPICE (SPICE.CH)**

This is one of two SPICE formatters supplied with OrCAD's **Schematic Design Tools**. This formatter can only be used to create hierarchical SPICE netlists. The flat SPICE formatter was discussed in the previous section. The formatting options and caveats explained in the flat SPICE netlist section apply to the hierarchical netlist as well.

The first option available for the SPICE format is:

- Do not append sheet number to labels

If this option is not selected, the SPICE formatter appends an underscore ( \_ ) and the sheet number to any labels.

▲ **CAUTION:** *If you select this option, labels with the same name on different sheets are merged into one net. This option is typically selected only when the design consists of a single schematic sheet.*

The second option available is:

- Include unconnected pins

If this option is selected, the SPICE formatter assigns all unconnected pins a unique net. If this option is not selected, the SPICE formatter assigns an unique net and reports an error.

The third available option is:

- Use node names

If this option is selected, the SPICE formatter uses the node names you have placed on the schematic (via labels and module ports) where available. Not all versions of SPICE support alphanumeric node names, so check your SPICE manual. If your version of SPICE does not allow alphanumeric node names, you can still give them numeric names (for example '17'). These numeric names will not interfere with the ones generated by the SPICE formatter, since formatter-generated node numbers begin at 10000 (except GND, which is always 0).

*Pipe commands*

You can place lines of text in your schematic to be included in the SPICE netlist. Use **Draft**'s **PLACE Text** command to place the text in your schematic, or use an editor to put the text in an ASCII file, then use **Draft**'s **BLOCK ASCII Import** command to import the contents of the file and place it on the worksheet.

Each line of text must start with the *pipe* character (`|`). (On many PC keyboards, the pipe character appears as a broken vertical bar.) The first line must be:

```
| SPICE
```

This tells the formatter to extract the information in the following lines of text when generating a SPICE netlist. The remaining lines can contain any information you want to include in the netlist. The lines following `| SPICE` are placed at the top of the netlist.

*Caveats*

**Schematic Design Tools** can create netlists larger than most PC-based SPICE programs accept. Consult your SPICE manual for the limits. If your PC meets SPICE's memory requirements, you can generate the largest netlist allowed.

The part value is used to pass modeling information to the netlist. For instance, resistor RS1 in figure B-4 has a value of 1K Ohms.

Use the special PSPICE.LIB or SPICE.LIB libraries supplied by OrCAD when generating a SPICE netlist. These libraries already have pin numbers on the parts and are compatible with most versions of SPICE. The PSPICE.LIB contains many specific part types, such as a 2N2222 NPN transistor, that are not provided in the generic SPICE.LIB.

To modify or create your own SPICE library, you must support the proper model pin numbers. To implement this, use the **Decompile Library** or **Edit Library** librarians and convert the desired OrCAD-supplied libraries into a library source file. Make the appropriate changes to the source file and recompile the modified library back to an object file using **Edit Library**.

All library part pin names should be changed to reflect the model node index. To find out the proper node ordering, see your SPICE manual.

As an example of what to change, the OrCAD-supplied NPN transistor has the pin names defined as base, emitter, and collector in the DEVICE.LIB library. For SPICE to understand the nodal information, the pin names must be changed from base, emitter, and collector to 2, 3, and 1 (as defined in the SPICE manual). Therefore, the library source file for an NPN transistor that is compatible with the SPICE pin numbering convention is as follows:

```
'NPN'  
REFERENCE 'Q'  
{X Size =} 2 {Y Size =} 2 {Parts per Package =} 0  
L1 SHORT IN '2'  
B2 SHORT IN '3'  
T2 SHORT IN '1'  
{ 0}.....##.....#  
{ 1}      ##      #  
.  
.  
.
```

Figure B-50. Library source file for the NPN transistor.

The hierarchical version of the SPICE netlist creates subcircuit (.SUBCKT) definitions for sheets in the hierarchy. These subcircuits are “called” via the X command. Since SPICE does not require the subcircuits to be defined before use, the hierarchy appears in normal form in the netlist (the root sheet at the top of the netlist file).

The SPICE formatter creates two files. In addition to the netlist file, it also creates a map file. The node numbers created by the formatter are placed in the .MAP file so you may cross reference the SPICE node numbers with the node names that you have specified in your schematic. The filename for this map file must be entered in the **Destination 2** entry box for the formatter.

The netlist in figure B-51 and the corresponding map file in figure B-52 were created from the schematic in figure B-45 with no options selected.

```

* Hierarchical (Complex) SPICE Example Revised: October 30, 1990
* OrCAD-07 Revision: A
* OrCAD
* 3175 NW Aloclek Drive
* Hillsboro, OR 97124-7135
* (503) 690-9881 Sales & Administration
* (503) 690-9722 Technical Support
.OPTIONS ACCT NODE OPTS NOPAGE
.MODEL DMOD D (VJ=0.6)
.MODEL QMOD NPN (BF=80 RB=100 TR=6NS TF=0.3NS)
.DC LIN VINPUT -5 20 0.25
.PLOT DC I(R7)
VCC 10010 0 DC 15V
VINPUT 10013 0 DC 1V
R1 10011 10017 6.8K
R2 10010 10011 47K
R3 0 10017 47K
R4 10013 10014 100K
R5 10013 10018 100K
R6 10010 10012 3.9K
R7 10010 10015 670
Q1 10015 10012 0 QMOD
XCOMPATOR1 10014 10011 0 10012 10010 EX7B
XCOMPATOR2 10018 10017 0 10012 10010 EX7B
.SUBCKT EX7B 10023 10020 10027 10024 10019
D6 10021 10020 DMOD
D7 10021 10019 DMOD
D8 10022 10019 DMOD
D9 10022 10023 DMOD
Q13 10025 10019 10019 QMOD
Q15 10026 10019 10019 QMOD
Q11 10024 10019 10027 QMOD
Q10 10019 10026 10027 QMOD
Q12 10026 10025 10027 QMOD
Q14 10025 10025 10027 QMOD
Q16 10019 10020 10027 QMOD
Q17 10019 10023 10027 QMOD
.ENDS
.END

```

Figure B-51. Example netlist in the hierarchical SPICE format.



```
10010 VCC DC 15V (sheet EX7)
10011 VUPPER (sheet EX7)
10013 VINPUT DC 1V (sheet EX7)
    0 GND (sheet EX7)
10017 VLOWER (sheet EX7)
10019 VPLUS (sheet EX7B)
10020 VINPLUS (sheet EX7B)
10023 VINMINUS (sheet EX7B)
10024 VOUT (sheet EX7B)
10027 VMINUS (sheet EX7B)
```

*Figure B-52. Example map file in the hierarchical SPICE format.*



## *Interpreting connectivity databases*

This appendix covers the following topics:

- ❖ Introduces connectivity databases
- ❖ Describes in detail the format of incremental and linked connectivity databases that are new with OrCAD's Release IV tools
- ❖ Includes a sample .INF file with comments

OrCAD's **Schematic Design Tools**, **Digital Simulation Tools**, and **PC Board Layout Tools** use a series of databases to organize design information.

Two of the databases, the *incremental connectivity database* and the *linked connectivity database*, organize information about a design's connectivity. Basic information about these databases is contained in *Chapter 9: Creating a netlist*.

The information in these two databases is stored in .INF format, which is described in this appendix. With an understanding of this file format, you can develop programs that use connectivity databases as source files or that convert files in other formats to connectivity databases.

---

### Overview of connectivity databases

A connectivity database is a group of one or more files that contain data extracted from schematic worksheets. The figure on the next page shows the relationship of INET, ILINK, IFORM, and HFORM, their source and destination files, and the name of each database.

**About the incremental connectivity database**

INET gathers data from title blocks, parts, and connections between parts on schematics. INET can also gather specially-marked text and stimulus, trace, and vector data placed on schematics. INET creates one .INF file for each sheet in the design and one .INX file for the entire design.

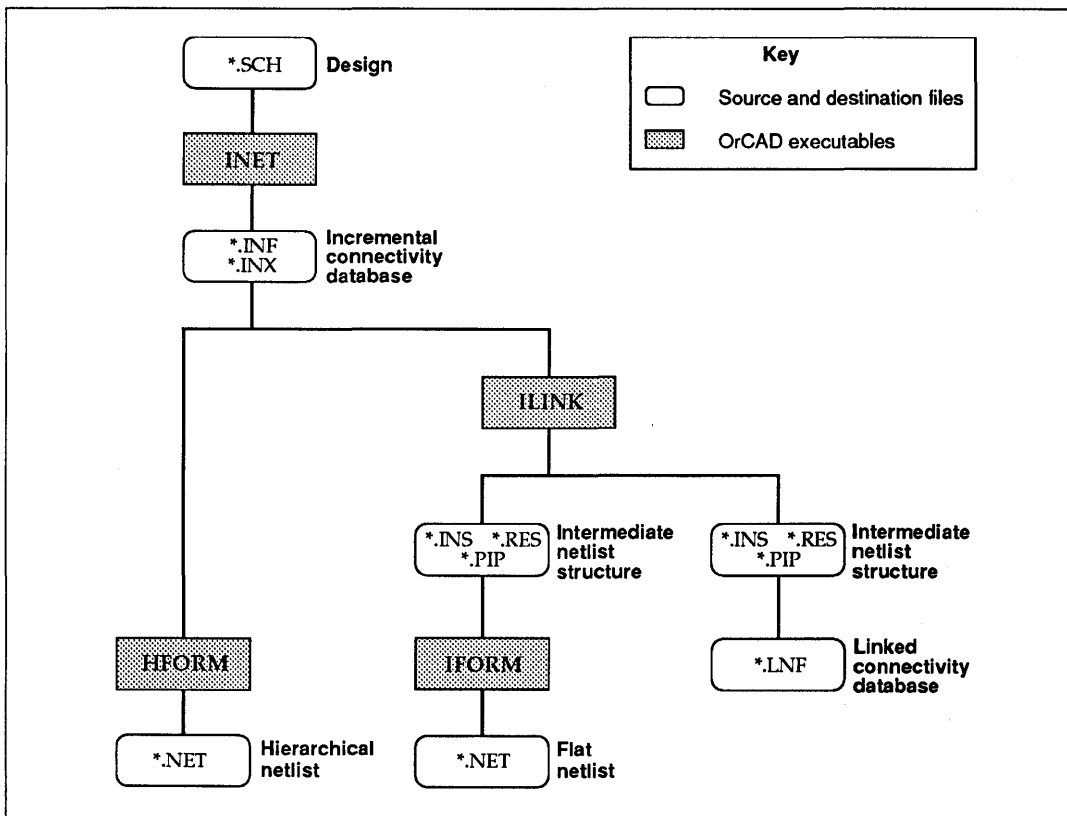

Release IV netlist process.

This appendix describes the format of .INF files; the .INX file is a text file containing a list of the sheets in the design. INET uses the list to track which sheets need updated .INF files. Together, the .INF files and .INX file are called the *incremental connectivity database*.

This database is the source for both HFORM and ILINK. OrCAD's Digital Simulation Tools uses the incremental connectivity database for simulation.

### About the linked connectivity database

Using the incremental connectivity database as input, ILINK, depending on the local configuration options selected, creates one or two databases: an intermediate netlist structure or an intermediate netlist structure and a linked connectivity database.

The linked connectivity database is in the same format as the .INF files, but is a single ASCII file with the .LNF extension. OrCAD's **PC Board Layout Tools** Release IV uses the linked connectivity database.

---

### Typographical conventions

This appendix contains several typographical, or notational, conventions that are in addition to or used differently than the rest of this reference guide. The conventions are:

*Italic text* This italic font shows a parameter representing specific data.

. . . Ellipses shows the continuation of a series.

"parameter" Double quotes surrounding a parameter indicate the parameter is a quoted token. The double quotes are part of the syntax.

?parameter? Question marks surrounding a parameter indicate the parameter can be either a number or a quoted token. The question marks are *not* part of the syntax.

parameter Parameters without double quotes or questions marks are either numbers or strings. Parameter definitions specify the type of token.

---

### Terminology

This section includes definitions for the various parts of .INF and .LNF files. You need to know these terms to correctly interpret the syntax of the statements defined in this appendix. See the *Glossary* for other terms.

**Token** A token is a group of characters preceded and followed by white space. Files in the .INF format contain six kinds of tokens: quoted tokens, strings, delimiters, commands, numbers, and sub-part codes.

**White space** Files in the .INF format may contain white space between tokens. White space can be a space, a horizontal tab, a carriage return, a line feed, or any combination of these characters. Spaces are also allowed within quoted tokens.

**Quoted token** A quoted token is a token that begins and ends with double quotes. Quoted tokens may contain any ASCII character except the back quote ( ` ) and may be empty. Two double quotes in a quoted token represent one double quote. This table shows some examples:

| <i>Quoted token</i> | <i>Corresponds to</i> |
|---------------------|-----------------------|
| "OUTPUT2"           | OUTPUT2               |
| ""SEC"" Carry"      | "SEC" Carry           |
| " "                 | (empty field)         |

*Examples of quoted tokens.*

**String** A string is an unquoted token that may contain only these characters:

```

a b c d e f g h i j k l m n o p q r s t u v w x y z
A B C D E F G H I J K L M N O P Q R S T U V W X Y Z
1 2 3 4 5 6 7 8 9 0
= - ! # $ % ' , . : ; = ? @ \ ^ _ * { } | ~ /

```

Strings may not contain spaces. For example:

```

Clock
42_22V10
@17#sec?

```

**Delimiter** A delimiter is an unquoted token comprised of a right or left parentheses. Delimiters occur in pairs to enclose groups of parameters. For example:

```

( R U1 11 ) ( R U2 9 )

```

|                      |  |
|----------------------|--|
| <b>Command</b>       | <p>A command is an unquoted token comprised of a back quote immediately followed by a single character from this list:</p> <pre>BEFH IJLPSTVW  </pre> <p>The characters must be uppercase. For example:</p> <pre>`H</pre>  |
| <b>Character</b>     | <p>A character is an unquoted token comprised of a single character. For example:</p> <pre>C</pre>   |
| <b>Number</b>        | <p>A number is an unquoted token comprised of characters from this list:</p> <pre>0 1 2 3 4 5 6 7 8 9<br/>A B C D E F a b c d e f</pre> <p>The format supports decimal, hexadecimal, and binary numbers and requires numbers to be in specific formats. For example, the parameter <i>absolute_identifier</i> must be an eight-digit hexadecimal number that does not include a suffix. For example:</p> <pre>023FB897</pre>   |
| <b>Sub-part code</b> | <p>A sub-part code is an unquoted token that begins and ends with square brackets. The square brackets may enclose only zeros (0) and ones (1). The binary digit 1 indicates a sub-part is used; 0 indicates a sub-part is unused. The number of digits indicates the number of sub-parts. For example:</p> <pre>[1010] Means four sub-parts, first and third used<br/>[1] Means a one-part package<br/>[0] Invalid sub-part code<br/>[] Means a zero-part package</pre> |

**Statement** A statement is a group of tokens that begins with a command and ends with either the blank space before the next command or with the end-of-file character. The tokens following the command are parameters. Statements may extend over multiple lines in a file. For example:

```
`W S "INPUT_PORT" 1 ( 0:0 )
```

**Parameter** A parameter is a single token or a group of tokens delimited by parentheses. The .INF format requires a specific type of token, such as a number or quoted token, for each parameter. For example:

```
absolute_identifier  
( S "signal_name" sheet_number )
```

---

## .INF format specification

The following sections list the types of statements that appear in incremental and linked connectivity databases in the order they appear in the .INF and .LNF files. Each discussion includes syntax and an example; notes contain software-related information.

For ILINK to read .INF files, the statements must appear in the order and frequency shown in the table below. The port and signal statements can be intermingled, as can the trace, vector, and stimulus statements.

| Command  | Name        | Frequency in .INF files | Frequency in .LNF files |
|----------|-------------|-------------------------|-------------------------|
| `H or `F | Header      | One                     | One                     |
| `B       | Title block | One                     | One                     |
| `L       | Link        | Zero or more            | None                    |
| `P       | Port        | Zero or more            | Zero or more            |
| `S       | Signal      | Zero or more            | Zero or more            |
| `E       | External    | Zero or more            | Zero or more            |
| `I       | Instance    | Zero or more            | Zero or more            |
| `J       | Joined      | Zero or more            | One or more             |
| `T       | Trace       | Zero or more            | Zero or more            |
| `V       | Vector      | Zero or more            | Zero or more            |
| `W       | Stimulus    | Zero or more            | Zero or more            |
| `        | Pipe        | Zero or more            | Zero or more            |

*Order and frequency of statements in .INF and .LNF files.*

## H or F Header

The header specifies information about the .INF file and must be the first line in the file. The syntax is:

```
` file_type format_version file_name
```

*file\_type* Tells whether the design is flat or hierarchical. *file\_type* is one of two characters: F for flat or H for hierarchical.

△ **NOTE:** *ILINK* accepts references to children in instance commands only from hierarchical .INF files.

*format\_version* Tells the version of the format. A string.

*file\_name* Tells the name of the .INF or .LNF file. A string.

### Example

```
` F 1.00 NEWALARM
```

## B Title block

The title block statement contains information from the title block. Each .INF file contains only one title block command. The title block statement immediately follows the header. The syntax is:

```
` B "sheet_number" "total_sheet_number" "sheet_size"
"date" "document_number" "revision_code" "title"
"organization_name" "address_line_1" "address_line_2"
"address_line_3" "address_line_4"
```

`` B` Begins parameters describing title block information.

`"sheet_number"` Tells the sheet number field on the title block.

`"total_sheet_number"` Tells the total sheets field on the title block.

`"sheet_size"` Tells the sheet size field on the title block.



|                     |  |
|---------------------|--|
| "date"              | Tells the date field on the title block.                 |
| "document_number"   | Tells the document number field on the title block.      |
| "revision_code"     | Tells the revision code field on the title block.        |
| "title"             | Tells the title field on the title block.                |
| "organization_name" | Tells the organization field on the title block.         |
| "address_line"      | Tells one of four address line field on the title block. |

*Example*

```
`B "1" "7" "A" "January 27, 1991" "1860107-001" "A"  
"Demonstration Schematic" "OrCAD LP"  
"3175 NW Aloclek Drive" "Hillsboro, Oregon 97124"  
"(503) 690-9881" " "
```

---

## L Link

Link statements specify the files to include in an intermediate netlist structure or a linked connectivity database. The syntax is:

```
`L netlist_filename
```

`L Begins the link statement.

*netlist\_filename* Tells the name of a file, with the extension omitted, to be linked. An .INF file contains one link statement for each linked file; .LNF files contain no link statements. A string.

△ **NOTES:** *ILINK* assumes the extensions are .INF.

*INET* and *ILINK* accept link commands only from a root schematic in a flat design. In addition, every schematic in a linked design must be a single sheet.

*Example*

```
`L CPU
`L GRAPHICS
```

**P** **Module port**

Module port statements define module port types and names. The syntax is:

```
`P module_port_type "module_port_name"
```

``P` Begins a module port definition.

`module_port_type` Tells a module port type from this table:

| <i>Character</i> | <i>Module port type</i> |
|------------------|-------------------------|
| I                | Input                   |
| O                | Output                  |
| B                | Bidirectional, IO       |
| U                | Unspecified             |
| S                | Supply                  |

*Module port characters and types.*

`"module_port_name"` Tells the name of the module port.

△ **NOTE:** *The supply port type is global, crossing all hierarchical boundaries.*

*Example*

```
`P I "OPEN CARRY"
```

---

## S Signal

Signal statements define signal names and the worksheets containing them. The syntax is:

```
`S "signal_name" sheet_number
```

`S Begins a signal definition.

"signal\_name" Tells the name of the signal.

sheet\_number Equals the number of the worksheet containing the signal. A whole decimal number.

### Example

```
`S "TRYIN1" 2
```

---

## E External

External statements specify configured libraries. The .INF file must contain an external statement for every library referenced on the schematic. The syntax is:

```
`E library_name
```

`E Begins the external statement.

library\_name Tells the name of a library. A string.

### Example

```
`E TTL.LIB
```

---

## I Instance

Instance statements declare the instance of objects on a schematic. The *part instance* syntax is for parts and sheetpath parts; the *child instance* syntax is for sheets and sheet parts. This discussion has two sections; the first describes the part instance syntax, and the second describes the child instance syntax.

❖ Part instance The part instance syntax is:

```
` I R "part_value" library "library_part_name"
absolute_identifier part_reference [sub_part_code]
"part_field_1" . . . "part_field_8" "module_field"
( "pin_name_1" ?pin_number_1? pin_type_1 )
( "pin_name_2" ?pin_number_2? pin_type_2 ) . . .
( "pin_name_n" ?pin_number_n? pin_type_n )
```

` I Begins a declaration of an instance of a part or child.

R Means the following parameters describe a part or a sheetpath part.

△ **NOTE:** Sheetpath parts may appear in .INF files as either parts or children, depending on the local configuration settings for INET. If the option **Descend into sheetpath parts** is selected, INET classifies sheetpath parts as children; otherwise, INET classifies sheetpath parts as parts.

*"part\_value"* Tells the part value field from the schematic.

*library* Tells the name, excluding extension, of the library containing the part. A string.

*"library\_part\_name"* Tells the name of the part in the library specified by the *library* parameter.

*absolute\_identifier* Tells the eight-digit hexadecimal number based on the date and time the part was first placed on the schematic. The number remains unchanged and is unique.

△ **NOTE:** When a part is one of several in a package, every part in the package has a unique absolute identifier. The absolute identifier in the .INF file is the latest one of all the parts in the package.

|                          |   |
|--------------------------|---|
| <i>part_reference</i>    | Tells a unique reference designator for the part containing the pin. A string.  |
| [ <i>sub_part_code</i> ] | Tells the number of sub-parts in a part and which of those sub-parts is used. A sub-part code. See the section <i>Terminology</i> for examples.   |
| " <i>part_field</i> "    | Tells user-supplied information from a part field. All eight part fields must be included, even if they are empty.<br><br>△ <i>NOTE: Parts that are packages may have only one set of part_field parameters. In cases where the sub-parts placed on a schematic have different information in the part fields, INET selects information for each field from the first sub-part it sees containing information in that field. INET looks at the sub-parts in absolute identifiers order, starting with the smallest absolute identifier.</i> |
| " <i>module_field</i> "  | Tells package description information consolidated from one or more of the part fields. The configuration of the <b>Module Value Combine</b> key field in <b>Schematic Design Tools</b> determines the combination.<br><br>△ <i>NOTE: When sub-parts have different information in part fields used to create the module-field parameter, INET uses the information from the first sub-part in the package even if the part fields are empty.</i>   |
| (                        | Begins a pin description. The instance command must contain one delimited set of pin parameters for each pin.   |
| " <i>pin_name</i> "      | Tells the name of the pin.  |

*?pin\_number?* Tells the number of a pin on a part or a sheet net on a sheetpath part. *?pin\_number?* is either a whole decimal number or a quoted token, depending on whether the characters are numeric or alphanumeric.

*pin\_type* Tells one of the pin types listed in the table below.

| <i>Character</i> | <i>Pin type</i>   |
|------------------|-------------------|
| I                | Input             |
| O                | Output            |
| B                | Bidirectional, IO |
| S                | Supply, power     |
| P                | Passive           |
| T                | Three-state       |
| C                | Open collector    |
| E                | Open emitter      |

*Characters for pin types.*

) Ends a parameter describing a pin.

*Example*

```
`I R "74LS00" TTL "74LS00" 74A3F631 U1 [1000] "" ""
"14PDIP" "" "" "" "" "" "14PDIP" ( "IO_A" 1 I )
( "IO_B" 4 I ) ( "IO_C" 9 I ) ( "IO_D" 12 I )
( "I1_A" 2 I ) ( "I1_B" 5 I ) ( "I1_C" 10 I )
( "I1_D" 13 I ) ( "O_A" 3 O ) ( "O_B" 6 O )
( "O_C" 8 O ) ( "O_D" 11 O ) ( "GND" 7 S )
( "VCC" 14 S )
```

❖ Child instance

The child instance syntax is:

```
`I C "sheet_file_name" absolute_identifier "sheet_name"
( "sheet_net_name_1" sheet_net_type_1 ) . . .
( "sheet_net_name_n" sheet_net_type_n )
```

`I Begins a declaration of an instance of a part or child.

C Means the next parameters describe a sheet or a sheet part.

△ *NOTE: Sheetpath parts may appear in .INF files as either parts or children, depending on the configuration settings for INET. If the option Descend into sheetpath parts is selected, INET classifies sheet-path parts as children; otherwise, INET classifies sheetpath parts as parts.*

*"sheet\_file\_name"* Tells the complete filename of the worksheet containing the child's logic.

*absolute\_identifier* Tells the absolute identifier, a unique eight-digit hexadecimal number based on the date and time the part was first placed on the schematic. This number remains unchanged.

*"sheet\_name"* Tells the schematic name of a child. This name is unique for each instance of a child on a worksheet; if several children reference the same schematic, each instance has the same *sheet\_file\_name* but a unique *sheet\_name*.

( Begins a parameter specifying information about a sheet net. The instance command must contain one delimited set of sheet net parameters for each sheet net.

*"sheet\_net\_name"* Tells the name of the sheet net.

*sheet\_net\_type* Tells one of the sheet net types listed in this table:

| <i>Character</i> | <i>Sheet net type</i> |
|------------------|-----------------------|
| I                | Input                 |
| O                | Output                |
| B                | Bidirectional, IO     |
| S                | Supply, power         |
| P                | Passive               |
| T                | Three-state           |
| C                | Open collector        |
| E                | Open emitter          |
| U                | Unspecified           |

*Characters for sheet net types.*

) Ends a sheet net description.

*Example*

```
`I C "SECOND.SCH" 54AF3C22 "SECOND_1" ( "A0" I )
( "A1" B ) ( "A2" U )
```

---

## J Joined

Join statements specify entities made electrically common in a net. An entity is a signal, module port, pin, or sheet net. Join statements can contain any combination of one or more entities. Join statements containing only one entity indicate single-node nets. The syntax is:

```
`J ( entity_1 ) ( entity_2 ) . . . ( entity_n )
```

`J Begins a list of electrically common entities.

*entity* Represents one of four types of parameters describing a signal, module port, pin, or sheet net. Each type has its own syntax as described on the next several pages.

*Example*

```
`J ( R U3 14 I ) ( R U2 "CENTER 1" P ) ( P S "VCC" )
( S "X0" 3 ) ( C "TRYAGAIN" "X" U )
```

### ❖ Signal

The syntax of a signal entity is:

```
( S "signal_name" sheet_number )
```

( S Begins a signal description.

*"signal\_name"* Tells the name of a signal.

*sheet\_number* Tells the number of the worksheet containing a signal. A whole decimal number.

) Ends a set of parameters describing a signal.



*Example*

( S "TRYIN1" 2 )

❖ **Module port**

The syntax of a module port entity is:

( P *module\_port\_type* "*module\_port\_name*" )

( P Begins a module port description.

*module\_port\_type* Tells the type of module port as listed in this table:

| <i>Character</i> | <i>Module port types</i> |
|------------------|--------------------------|
| I                | Input                    |
| O                | Output                   |
| B                | Bidirectional            |
| U                | Unspecified              |
| S                | Supply, power            |

*Characters for module port types.*

"*module\_port\_name*" Tells the name of the module port.

) Ends a module port description.

*Example*

( P S "VCC" )

❖ **Pin**

The syntax of a pin entity is:

( R *part\_reference* ?*pin\_number*? *pin\_type* )

( R Begins a pin description.

*part\_reference* Tells the unique reference designator for the part containing the pin. A string.

*?pin\_number?* Tells the pin number. *?pin\_number?* is either a whole decimal number or a quoted token. When the pin is a zero-part-per-package pin, *pin\_number* is the pin name.

*pin\_type* Tells one of the pin types listed in this table:

| <i>Character</i> | <i>Pin type</i>   |
|------------------|-------------------|
| I                | Input             |
| O                | Output            |
| B                | Bidirectional, IO |
| S                | Supply, power     |
| P                | Passive           |
| T                | Three-state       |
| C                | Open collector    |
| E                | Open emitter      |

*Characters for pin types.*

) Ends a pin description.

*Example*

```
( R COAX1 "CENTER 1" O ) ( R U2 9 B )
```

❖ **Sheet net**

The syntax of a sheet net entity is:

```
( C "sheet_name" "sheet_net_name" sheet_net_type )
```

( C Begins a sheet net description.

*"sheet\_name"* Tells the part value of a sheet part or sheetpath part, or the name of a sheet.

*"sheet\_net\_name"* Tells the name of the sheet net.

*sheet\_net\_type* Tells one of the sheet net types listed in the table at the top of the next page.

| <i>Character</i> | <i>Sheet net types</i> |
|------------------|------------------------|
| I                | Input                  |
| O                | Output                 |
| B                | Bidirectional          |
| S                | Supply, power          |
| P                | Passive                |
| T                | Three-state            |
| C                | Open collector         |
| E                | Open emitter           |
| U                | Unspecified            |

*Characters for sheet net types.*

- ) Ends a sheet net description.

*Example*

```
( C "TRY" "A0" I )
```

---

## T Trace

Trace statements specify trace information for OrCAD's **Digital Simulation Tools**. Four types of trace statements are possible: signal, pin, sheet net, and bus. Each is described separately.

### ❖ Signal

The syntax of a signal trace is:

```
` T S "signal_name" sheet_number "signal_display_name"
```

` T Begins trace information.

S Begins a signal definition.

"*signal\_name*" Tells the name of the signal.

*sheet\_number* Tells the number of the worksheet containing the signal.  
A whole decimal number.

- "signal\_display\_name"* Tells the trace name to be displayed during simulation.
- Example*
- ```
`T S "OUTPUT" 4 "Y Output"
```
- ❖ **Pin**
- The syntax of a pin trace is:
- ```
`T R part_reference ?pin_number? "part_display_name"
```
- `T Begins parameters describing trace information.
- R Means the following three parameters describe a pin or a sheet net. The next section describes the parameters for sheet nets.
- part\_reference* Tells the unique reference designator for the part containing the pin or sheet net. A string.
- ?pin\_number?* Tells the pin number. Either a whole decimal number or quoted token.
- "part\_display\_name"* Tells the trace name to be displayed during simulation.
- Example*
- ```
`T R U1 11 "ALTERNATE"
```
- ❖ **Sheet net**
- The syntax of a sheet net trace is:
- ```
`T R sheet_name "sheet_net_name" "sheet_display_name"
```
- `T Begins trace information.
- R Means the following parameters describe a sheet net or pin. The previous section describes the parameters for pins.
- sheet\_name* Tells the name of the sheet. A string.

*"sheet\_net\_name"* Tells the sheet net name.

*"sheet\_display\_name"* Tells the trace name to be displayed during simulation.

*Example*

```
\ T R U1 "ALTERNATE" "ALTERNATE"
```

❖ **Bus**

The syntax of a bus trace is:

```
\ T B "bus_name[range]" sheet_number display_type
"bus_display_name"
```

\ T Begins trace information.

B Means the following three parameters describe a bus.

*"bus\_name[range]"* Tells the name of the bus immediately followed by a range index. If the range is a single value, the index is a decimal number. If the range is more than one value, square brackets enclose the index that is comprised of two whole decimal numbers separated by two periods. The smallest value must be listed first. For example:

```
"COUNTER2"
"COUNTER[0..1]"
```

*sheet\_number* Tells the number of the worksheet containing the bus. A whole decimal number.

*display\_type* Tells one of the display types listed in the table below.

| <i>Character</i> | <i>Display type</i> |
|------------------|---------------------|
| B                | Binary bus          |
| D                | Decimal bus         |
| H                | Hexadecimal bus     |
| O                | Octal bus           |

*Characters for bus types.*

*"bus\_display\_name"* Tells the name of the bus to display during simulation.

△ *NOTE: If no value for display\_type is provided, INET assigns hexadecimal.*

*Example*

```
`T B "AD[0..7]" 4 H "ADDRESS"
```

## **V Vector**

Vector statements specify vector information for OrCAD's **Digital Simulation Tools**. Three types of vector specifications are possible: signal, pin, and bus.

### ❖ Signal

The syntax of a signal vector is:

```
`V S "signal_name" sheet_number column_number
```

``V` Begins parameters describing vector information.

`S` Means the following three parameters describe signals.

*"signal\_name"* Tells the name of the signal.

*sheet\_number* Tells the number of the worksheet containing the signal. A whole decimal number.

*column\_number* Tells the column number in the test vector. A whole decimal number.

*Example*

```
`V S "OUTPUT" 4 13
```

### ❖ Pin

The syntax of a pin vector is:

```
`V R part_reference ?pin_number? column_number
```

``V` Begins parameters describing vector information.

R Means the following three parameters describe a pin.

*part\_reference* Tells the unique reference designator for the part containing the pin. A string.

*?pin\_number?* Tells the pin number. Either a quoted token or a whole decimal number

*column\_number* Tells the column number in the text vector. A whole decimal number.

*Example*

```
`V R U1 3 8
```

❖ **Bus**

The syntax of a bus vector is:

```
`V B "bus_name[range]" sheet_number  
first_column_number
```

`V Begins vector information.

B Means the following three parameters describe a bus.

*"bus\_name[range]"* Tells the name of the bus immediately followed by a range index. If the range is a single value, the index is a decimal number. If the range is more than one value, square brackets enclose the index that is comprised of two whole decimal numbers separated by two periods. The smallest value must be listed first.

*sheet\_number* Tells the number of the worksheet containing the bus. A whole decimal number.

*first\_column\_number* Tells the starting column number in the test vector. A whole decimal number.

*Example*

```
`V B "AD[0..7]" 4 14
```

## W Stimulus

Stimulus statements specify stimulus information for OrCAD's **Digital Simulation Tools**. Three types of stimulus specifications are possible: signal, pin, and bus. Stimulus statements for signals and pins can contain set and branch parameters, which are described first.

### ❖ Set parameter

The syntax of a set parameter is:

*time*: *function*

*time* Tells the time at which a state function will occur. An unsigned whole number.

*function* Tells a state function as shown in the table below.

| <i>Character</i> | <i>State function</i>       |
|------------------|-----------------------------|
| 0                | Set to value 0              |
| 1                | Set to value 1              |
| U                | Set to undefined state      |
| Z                | Set to high impedance state |
| T                | Toggle the signal state     |

*Characters for state functions.*

*Example*

100:Z

### ❖ Branch parameter

The syntax of a branch parameter is:

*time1*:G:*time2*

*time1* Tells the start time. An unsigned whole number.

G Represents the GOTO function.

*time2* Tells the target time. An unsigned whole number.



△ **NOTE:** Only one branch statement per stimulus is allowed.

*Example*

0:G:200

❖ **Signal**

The syntax of a signal stimulus is:

``W S "signal_name" sheet_number ( stimuli )`

``W` Begins parameters describing stimulus information.

`S` Means the following parameters are for signals.

`"signal_name"` Tells the name of the signal.

△ **NOTE:** *Digital Simulation Tools* does not recognize signal names containing periods (.) anywhere in the signal name or colons (:) at the end of the signal name.

`sheet_number` Tells the number of the worksheet containing the signal. A whole decimal number.

`(` Begins a list of stimuli.

`stimuli` Lists one or more set or branch parameters.

`)` Ends a list of stimuli.

*Example*

``W S "INPUT" 3 ( 0:0 50:1 100:T 200:G:50 )`

❖ **Pin**

The syntax of a pin stimulus is:

``W R part_reference ?pin_number? (stimuli )`

- ``W` Begins a stimulus description.
- `R` Means the following parameters describe a pin.
- `part_reference` Tells the unique reference designator for the part containing the pin. A string.
- `?pin_number?` Tells the pin number. Either a whole decimal number or quoted token.
- `(` Begins a list of stimuli.
- `stimuli` Lists one or more set or branch parameters.
- `)` Ends a list of stimuli.

*Example*

```
`W R U1 3 ( 0:1 50:T )
```

❖ **Bus**

The syntax of a bus stimulus is:

```
`W B "bus_name[range]" sheet_number ( stimuli )
```

- ``W` Begins parameters describing stimulus information.
- `B` Means the following three parameters describe a bus.
- `"bus_name[range]"` Tells the name of the bus immediately followed by a range index. If the range is a single value, the index is a decimal number. If the range is more than one value, square brackets enclose the index that is comprised of two whole decimal numbers separated by two periods. The smallest value must be listed first.

△ **NOTE:** *Digital Simulation Tools does not recognize bus names containing periods (.) anywhere in the bus name or colons (:) at the end of the bus name. You can include periods in the range index.*

*sheet\_number* Tells the number of the worksheet containing the bus. A whole decimal number.

( Begins a list of stimuli.

*stimuli* Lists stimuli information. Version 1.00 of the .INF format does not define a syntax for bus stimuli, so the stimuli can be any valid string.

△ **NOTE:** *Digital Simulation Tools simulates only signals and parts.*

) Ends a list of stimuli.

#### *Example*

```
`W B INPUTBUS[1..4] 3 ( 0:1 50:T )
```

---

## | Pipe commands

Pipe commands contain text extracted from the schematic. For the text to be extracted, each line must begin with a pipe (|) symbol. Pipe text may contain any type of information; each program that uses the .INF file scans the pipe commands for keywords and uses those it recognizes. OrCAD tools recognize the keywords PLD, VSTModel, SPICE, and others. An .INF or .LNF file may contain more than one section of pipe commands. Pipe commands appear at the end of the file. The syntax is:

```
` |  
" | keyword"  
" | information_line_1"  
" | information_line_2"
```

- ` | Begins a section of pipe text.
- " | *keyword*" Lists a command word or string for a specific program or any text.
- " | *information\_line*" Lists text.

△ **NOTE:** Each section of pipe commands on a schematic created with OrCAD's Schematic Design Tools should begin in a different column.

*Example*

```
` |  
"| PLDX1 in:(A1, A2, B1, B2),"  
"| io:(Y1, Y2)"  
"| Y1 = A1 & B1"  
"| Y2 = A2 # B2"
```

---

## Sample .INF file

The sample .INF file in this section was created from the schematic drawing below. The schematic shows a variety of objects and how they appear in an .INF file, but is not a working circuit.

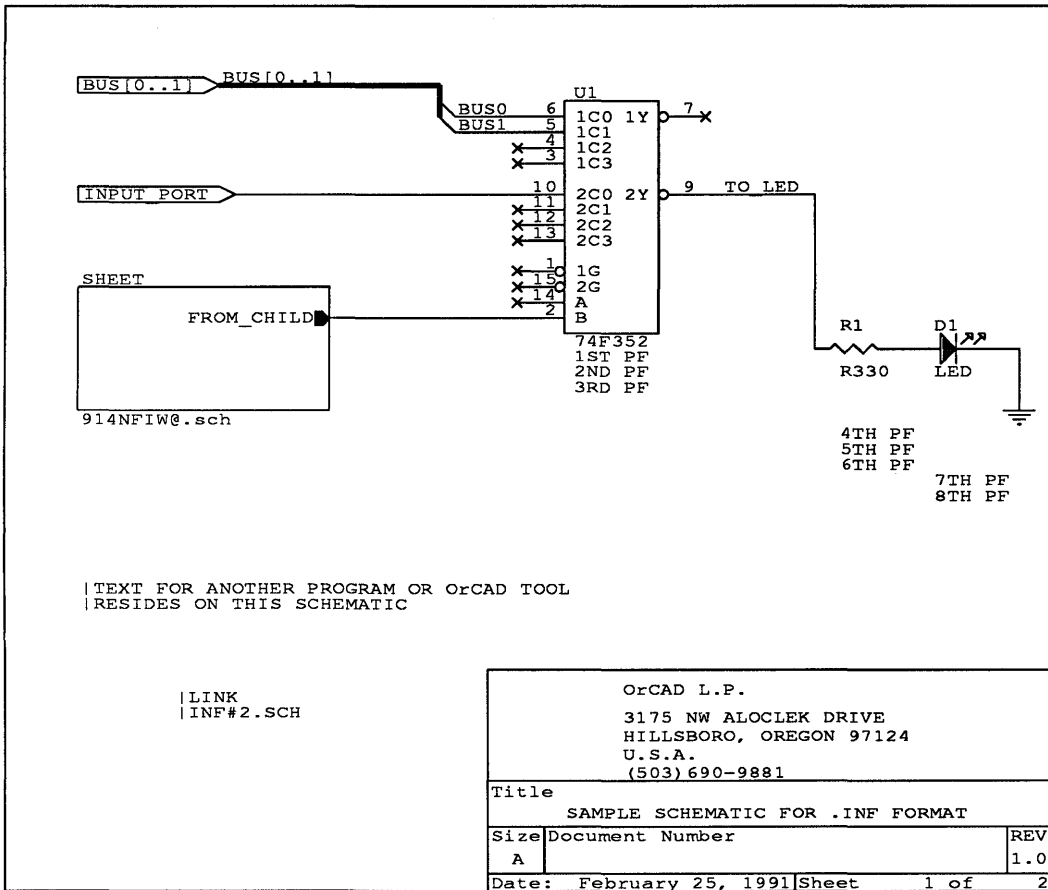

The schematic TEST\_INF.SCH.

| Comments  | Statements  |
|---|---|
| TEST_INF.SCH is a hierarchy<br>Title block information  | `H 1.00 TEST_INF<br>`B "1" "2" "A" " February 19, 1991" "" "1.0"<br>"SAMPLE SCHEMATIC FOR .INF FORMAT" "OrCAD L.P."<br>"3175 NW ALOCLEK DRIVE" "HILLSBORO, OREGON 97124"<br>"U.S.A." "(503) 690-9881"   |
| Link statement, for example<br>Module ports on the parent   | `L INF#2<br>`P S "VCC"<br>`P I "INPUT_PORT"<br>`P S "GND"<br>`P I "BUS0"<br>`P I "BUS1"   |
| Signal on the parent<br>Configured libraries  | `S "TO_LED" 1<br>`E TTL.LIB<br>`E DEVICE.LIB  |
| Instance of an LED from<br>DEVICE.LIB   | `I R "LED" DEVICE.LIB "LED" 7B0738E9 D1 [] "" "" "" ""<br>"" "" "7TH PF" "8TH PF" "" "ANODE" ( "ANODE" P )<br>( "CATHODE" "CATHODE" P )   |
| Instance of a resistor from<br>DEVICE.LIB   | `I R "R330" DEVICE.LIB "R" 7B0738E8 R1 [] "" "" "" "4TH PF"<br>"5TH PF" "6TH PF" "" "" "" ( "1" "1" P ) ( "2" "2" P )   |
| Instance of a 4-to-1<br>multiplexer from TTL.LIB  | `I R "74F352" TTL.LIB "74F352" 7B07BEA3 U1 [1]<br>"1ST PF" "2ND PF" "3RD PF" "" "" "" "" "" ""<br>( "1C0" 6 I ) ( "1C1" 5 I ) ( "1C2" 4 I ) ( "1C3" 3 I )<br>( "2C0" 10 I ) ( "2C1" 11 I ) ( "2C2" 12 I ) ( "2C3" 13 I )<br>( "1G" 1 I ) ( "2G" 15 I ) ( "A" 14 I ) ( "B" 2 I )<br>( "1Y" 7 O ) ( "2Y" 9 O ) ( "VCC" 16 S ) ( "GND" 8 S )   |
| Instance of a child—a sheet<br>Join statements listing the<br>contents of each net on<br>the parent | `I C "914NFIW@.sch" 7B5427A5 "SHEET" ("FROM_CHILD" O )<br>`J ( P S "VCC" ) ( R U1 16 S )<br>`J ( P I "BUS0" ) ( R U1 6 I )<br>`J ( P I "BUS1" ) ( R U1 5 I )<br>`J ( P I "INPUT_PORT" ) ( R U1 10 I )<br>`J ( R U1 9 O ) ( S "TO_LED" 1 ) ( R R1 "1" P )<br>`J ( R U1 1 I )<br>`J ( C "SHEET" "FROM_CHILD" O ) ( R U1 2 I )<br>`J ( R D1 "CATHODE" P ) ( P S "GND" ) ( R U1 8 S )<br>`J ( R R1 "2" P ) ( R D1 "ANODE" P ) |
| Trace, vector, and stimulus<br>information from a bus   | `T B "BUS[0..1]" 1 H "TRACENAME"<br>`V B "BUS[0..1]" 1 5<br>`W B "BUS[0..1]" 1 ( 2:200 )  |
| Stimulus, vector, and trace<br>information from a signal  | `W S "INPUT_PORT" 1 ( 0:0 0:G:0 0:G:10 )<br>`V S "INPUT_PORT" 1 10<br>`T S "INPUT_PORT" 1 "INPUT_PORT"  |
| Vector, stimulus, and trace<br>information from a part  | `V R U1 2 6<br>`W R U1 2 ( STIM_CHILD )<br>`T R U1 2 "TRACE_CHILD"  |
| Pipe text from the worksheet  | ` <br>" TEXT FOR ANOTHER PROGRAM OR OrCAD TOOL"<br>" RESIDES ON THIS SCHEMATIC"   |

Sample .INF file.

## Differences between .INF and .LNF files

Both .INF and .LNF files are in the .INF format described in this appendix. However, when ILINK links a series of .INF files to create a .LNF file, it uses the following guidelines during the process.

### Sub-parts in .LNF files

It is possible that sub-parts from a single package reside on separate schematics and have conflicting information in the part fields. When this happens, ILINK merges the instance commands for the sub-parts, using the first parameter containing information. ILINK combines the pin number parameters, discarding duplicates such as power and ground pins.

For example, if the following two instance commands are in separate .INF files processed by ILINK, the .LNF file contains the third instance command.

The instance command below is from the first .INF file.

```
`I R 74LS21 TTL.LIB "74LS21" 34D55A33 U1 [10] "" ""  
"14PDIP" "" "" "" "" "" "14PDIP" ( "IOA" 1 I )  
( "I1A" 2 I ) ( "I2A" 4 I ) ( "I3A" 5 I )  
( "OA" 6 0 ) ( "GND" 7 S ) ( "VCC" 14 S )
```

This instance command is from the second .INF file:

```
`I R 74LS21 TTL.LIB "74LS21" 34D55A16 U1 [01] "" ""  
"16PDIP" "" "JOE" "" "" "" "16PDIP" ( "IOB" 9 I )  
( "I1B" 10 I ) ( "I2B" 12 I ) ( "I3B" 13 I )  
( "OB" 8 0 ) ( "GND" 7 S ) ( "VCC" 14 S )
```

This is the resulting instance command in the .LNF file:

```
`I R 74LS21 TTL.LIB "74LS21" 34D55A33 U1 [11] "" ""  
"14PDIP" "" "JOE" "" "" "" "14PDIP" ( "IOA" 1 I )  
( "I1A" 2 I ) ( "I2A" 4 I ) ( "I3A" 5 I ) ( "OA" 6 0 )  
( "GND" 7 S ) ( "VCC" 14 S ) ( "IOB" 9 I )  
( "I1B" 10 I ) ( "I2B" 12 I ) ( "I3B" 13 I )  
( "OB" 8 0 )
```

Notice that ILINK used the latest absolute identifier, 34D55A33, and the first occurrences of the part fields and module field.



## Creating a custom netlist format

This appendix describes the process of creating a custom netlist format to use with OrCAD's Schematic Design Tools. You specify a netlist format for flat netlists in a netlist format file or for hierarchical netlists in a hierarchical netlist format file.

IFORM uses the netlist format file and an intermediate netlist structure created by ILINK to create a flat netlist in the format you defined.

HFORM uses the hierarchical netlist format file and an incremental connectivity database created by INET to create a hierarchical netlist in the format you defined. The figure below shows both processes.

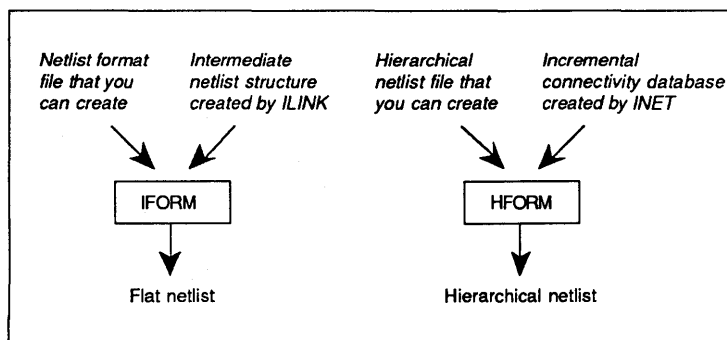

*Figure D-1. Source and destination files for IFORM and HFORM.*

To create a custom netlist format file, you should be familiar with programming, preferably in the C language.



---

## About netlist formats

At the end of OrCAD's netlist process, IFORM and HFORM use netlist format files and OrCAD databases to create flat and hierarchical netlists in formats you select from **Local Configuration** screens. OrCAD supplies over thirty format files for the most common file formats; you can create your own format files for uncommon or situation-specific formats.

For more information about the netlist process, see chapters 9, 10, and 11 in this reference guide.

The two types of netlist formats are:

- ❖ A flat format where all ports and signals are resolved across the entire design.
- ❖ A hierarchical format where all instances of sheets and subsheets, called children, remain intact and are used to reference subnets.

Either type of netlist format can be part-oriented or net-oriented.

### Flat formats

The flat format gives all parts unique references and all nodes unique names. Although this view accurately reflects the design, it removes evidence of the structure of the design.

### Hierarchical formats

The hierarchical format retains the hierarchical format of the original design, complete with all subsheets and non-unique references and nodes.

### Part and net orientations

Both flat and hierarchical netlist formats can focus on parts or on nets. IFORM and HFORM manage separate data structures for parts, nets, and children; you use different functions to access the data structures. A subset of the pre-defined functions work only when creating part-oriented netlists; the remaining functions work for both net- and part-oriented netlists. For specifics, see the section *Data structures*.

**OrCAD-supplied  
formats**

OrCAD supplies format files for over thirty formats with **Schematic Design Tools**. The formats and sample netlists are in *Appendix B: Netlist formats*.

**Customer-  
contributed formats**

In addition to OrCAD-supplied netlist formats, customers who create netlist format files can post them on OrCAD's bulletin board so other customers can use them.

---

**How to create a  
new format**

This section describes the process of creating a new netlist format; the following sections contain suggestions and syntax information.

1. **Know what you want the destination file to look like.**

You should have sample netlists in the desired format, and, if possible, a specification for the format.

2. **Check for one or more formats that are similar to what you want.**

Look through *Appendix B: Netlist formats* in the *Schematic Design Tools Reference Guide* and find one or two netlist formats that are similar to the one you want. If your netlist format is in two parts like the Spice or Vectron formats, find the one that is closest to your format. In the following steps, you will use the corresponding format files as templates for the new format.

3. **Examine the .CF or .CH files and compare them to the netlists they create.**

Examine the .CF or .CH files for the formats you identified as being similar to yours. Determine how IFORM or HFORM creates the netlist, looking at how nets and pins are written.

4. **Identify what changes you need to make.**

Identify the changes you need to make in the .CF or .CH file. When necessary, refer to the syntax and reference information later in this appendix.

**5. Make the changes.**

Edit a copy of the .CF or .CH file that is nearest to what you want using a text editor or **Edit File**. Be sure to name it something different.

**6. Test the format file.**

Create a netlist for a sample schematic using the **Create Netlist** or **Create Hierarchical Netlist** tool on the **Schematic Design Tools** work screen.

Chances are, IFORM or HFORM will report error messages. A list of the messages and explanations is at the end of this appendix.

**7. Fine tune the format file.**

Go back to step 3 and identify what worked and what didn't, then redo steps 4 through 7 until IFORM or HFORM creates a netlist that matches your specification.

---

## About format files

Netlist format files must contain specific constructs that IFORM and HFORM can use. This section describes language guidelines, functions, and symbols. Following sections, including the reference portion of this appendix, describe individual elements of format files.

**File names** Netlist format files must have the extension .CF for flat netlists IFORM creates and .CH for hierarchical netlists HFORM creates.

**Language** The language used in format files is a subset of the C language. Local and global variables are supported, as well as function calls and recursion. The following list contains exceptions, restrictions, and conventions:

- ❖ **Int** and **char** are the only data types supported.
- ❖ All functions are assumed to return **int**.
- ❖ **Argument** passing to user-defined functions is not supported.

- ❖ If, if/else, while, do-while, and for statements are supported.
- ❖ All blocks must begin with an opening curly brace ( { ) and end with a closing curly brace ( } ).
- ❖ Nesting statements surrounded by curly braces is supported.
- ❖ The ASCII character set is supported except that symbol names may not contain double quotes.
- ❖ These operations are supported:
 

|         |    |         |    |
|---------|----|---------|----|
| +       | -  | /       | *  |
| =       | == | !=      | %  |
| >       | <  | >=      | <= |
| unary + |    | unary - |    |
- ❖ Bit and logical operations are not supported.
- ❖ Arrays and pointers are not supported.
- ❖ Quoted strings are supported.
- ❖ Quoted strings can contain these escapes:
 

|    |          |    |           |
|----|----------|----|-----------|
| \n | new line | \b | backspace |
| \t | tab      | \f | form feed |
| \r | return   |    |           |
- ❖ Quoted strings can contain backslashes ( \ ) to indicate the next character is to appear within the string. For example, this represents a double quote ( " ) in a string:
 

```
\"
```

This represents a backslash in a string:

```
\\
```

**Functions** IFORM and HFORM recognize both a subset of C-language functions and OrCAD-defined functions; you can define others. The reference part of this appendix describes both types of functions. For information about defining your own functions or symbols, see a C-language reference manual such as *The C Programming Language* by Brian W. Kernighan and Dennis M. Ritchie.

**Standard symbols** IFORM and HFORM recognize a number of pre-defined standard symbols. For a list of the standard symbols, see the section *Symbol reference*.

**User-defined symbols** IFORM and HFORM recognize up to thirty-six user-defined symbols. You refer to each symbol by the name you specify in its definition. Symbol names may be up to thirty-two characters long and may contain any ASCII character except the double quote. User-defined symbols can be set, reset, deleted, and printed.

Two user symbols are already be defined for you. See the discussions for **ExitType** and **LocalSignal** for more information about these symbols.

---

## Flat format

This section includes pseudocode of the loop that IFORM executes to perform netlist formatting. Pseudocode is an English-like description of what happens in a program. For information about required functions in .CF files, see the section *Required functions*.

Following the pseudocode is a “Hello World” example that, like many first examples of computer languages, simply writes the words “Hello World” to a file.

```
FormatNetlist() /* Pseudocode for creating a flat netlist */
{
    InitializeFormatModule();

    /* either output a header directly for a net based netlist
     * or create the part data base for a part based netlist */
    WriteHeader();

    NetNumber = 0;
    read the TypeCode from the Resolved File

    while not at the end of the Resolved File
    {
        increment NetNumber

        NotConnected = FALSE;

        switch (TypeCode)
        {
            'L' :    read the SignalType
                   read the SignalNameString from resolved file
            | 'P' :    SignalType = Byte('u');
                   read the SignalNameString from resolved file
            | 'U' :    NotConnected = TRUE;
            | 'N' :    /* do nothing */
        }

        HandleNodeName(); /* part- or net-oriented */

        FirstTime = TRUE;
        NetCount = 0;
    }
}
```

*Pseudocode of the format loop IFORM executes (continued).*

```
    read the ReferenceString
    while ReferenceString is not empty
    {
        read PinNumberString from resolved file
        read PinNameString from resolved file
        read PinIndex from resolved file
        read PartName from resolved file
        read ModuleName from resolved file
        read PinType from resolved file

        /* Either output to a file directly for net-oriented netlists
           or add the net to an internal data structure for part-oriented
           netlists          */
        WriteNet();

        FirstTime = FALSE;
        read the ReferenceString
    }
    WriteNetEnding(); /* can be empty if part-oriented */
    read the TypeCode from the Resolved File
}

ProcessFieldStrings();

/* output the trailer for net-oriented netlists or output the netlist
   itself for a part-oriented netlist      */
WriteNetListEnd();
} /* end of FormatNetlist */
```

*Pseudocode of the format look IFORM executes (continued from previous page).*

```
/* Hello World example for a flat netlist */

Initialize()
{
/* add a symbol called Formatter */
AddSymbol( "Formatter" );

/* set formatter to a value */
SetSymbol( Formatter, "Hello World" );
}

WriteHeader()
{
/* now output the symbol to the first file */
WriteSymbol( 1, Formatter );

/* write a newline to the first file */
WriteCrLf( 1 );
}

/* the following required functions are not used but are still required
   in the file, so leave them empty */
WriteNet()
{
}

HandleNodeName()
{
}
WriteNetEnding()
{
}
ProcessFieldStrings()
{
}
WriteNetListEnd()
{
}
```

*"Hello World" example for a flat netlist.*



## Hierarchical format

This section includes pseudocode of the loop that HFORM executes to perform netlist formatting. For information about required functions in .CH files, see the section *Required functions*.

Following the pseudocode is a "Hello World" example.

```
FormatNetList() /* Pseudocode for creating a hierarchical netlist */
{
    InitializeFormatModule();
    InitializeParser();

    /* call the user initialization function */
    Initialize();

    NetNumber := 0;
    depth := 0;

    scan for all parts in the design and build a small version
    of the libraries containing only the parts used in the design

    add all files found in the design to the file stack

    set the worksheet number to zero
    WHILE not empty file stack
    {
        increment the worksheet number

        open the top file on the stack
        pop the file stack

        PreFile;

        parse the current .inf file

        PostFile();
    }

    /* initialize the pipe file and call the user post processing function,
    finally, cleanup and leave */
    InitializePipeFile();
    PostProcess();
    CleanupFormatModule;

    exit with the indicated code
} /* end of FormatNetlist */
```

*Pseudocode of the format loop HFORM executes.*

```

/* Hello World example for a hierarchical netlist */

Initialize()
{
/* add a symbol called Formatter */
AddSymbol( "Formatter" );

/* set formatter to a value */
SetSymbol( Formatter, "Hello World" );

/* now output the symbol to the first file */
WriteSymbol( 1, Formatter );

/* write a newline to the first file */
WriteCrLf( 1 );
}

/* the following required functions are not used but are still required
 * in the file, so leave them empty
 */
PreFile()
{
}
PostFile()
{
}
PostProcess()
{
}

```

*"Hello World" example for a hierarchical netlist.*

## Required functions

IFORM and HFORM require netlist format files to include the following functions in any order:

*Required functions  
for IFORM*

**HandleNodeName();**  
**Initialize();**  
**ProcessFieldStrings();**  
**WriteHeader();**  
**WriteNet();**  
**WriteNetEnding();**  
**WriteNetListEnd();**

*Required functions for  
HFORM*

**Initialize();**  
**PreFile();**  
**PostFile();**  
**PostProcess();**

## **Data functions**

IFORM and HFORM access data from data structures and from instance files. This section describes data structures and instance files.

### **Data structures**

IFORM and HFORM use four data structures to manage data extracted from the intermediate netlist structure and the incremental connectivity database, respectively. The data structures contain net, part, and child data.

IFORM accesses the part, part-oriented, and net-oriented data structures. HFORM accesses the part, child, and net-oriented data structures for each file on the file stack.

The following sections describe four types of data structures: part, child, net-oriented, and part-oriented, and lists the functions you use with each type.

### *Part data structure*

The part data structure contains information about all parts; it contains the symbols **ReferenceString**, **PartName**, **ModuleName**, **TimeStamp**, **PinNameString**, **PinNumberString**, and **PinType**.

HFORM accesses and traverses the part data structure when you use these functions in .CH files :

```
FirstPin();  
int AccessPart( user_symbol );  
int FirstPart();  
int NextPart();  
int NextPin();  
int PinCount();  
int SetPartIndex( integer_constant );  
int SetPartIndex( variable );  
int SetSignal();
```

IFORM, however, accesses part data information from part-oriented data structures as described on the next page.

*Child data structure*      The child data structure, accessed only by HFORM, contains information about the children for the current worksheet in a hierarchical design. The child data structure is comprised of children and the sheet nets on each child; each child and sheet net is represented by standard symbols. The standard symbols are **PinNameString**, **PinNumberString**, **PinType**, **ModuleName**, **PartName**, **ReferenceString**, and **TimeStamp**.

The functions that access child data structures are:

```
FirstChildPin();
int AccessChild( user_symbol );
int ChildPinCount();
int FirstChild();
int NextChild();
int NextChildPin();
```

*Net-oriented data structure*

Net-oriented databases contain all the net information in flat designs and all the net information for the current worksheet in hierarchical designs. The data is arranged by nets, with information about nodes and parts subordinate to the net information. Both IFORM and HFORM can access the net-oriented database.

HFORM can also access data in a net-oriented data structure from a part perspective.

The net-oriented data structure is the default data structure. Until you load another data structure, a net from the net-oriented data structure is current. Net-oriented data structures are comprised of nets and nodes comprised of standard symbols.

IFORM and HFORM access net-oriented data structures differently. IFORM scrolls through data structure automatically and you have no control over what is current unless you traverse the part-oriented data structure and use the function **SetSignal()** to synchronize the two data structures.

HFORM, however, accesses information from net data structures in a variety of ways depending on which functions you use to traverse the data structure. When you use such a function to change the current net, the first node on that net also becomes current.

The functions for net-oriented data structures you use in .CH format files for HFORM are:

```
FirstNet();
FirstNode();
int NextNet();
int NextNode();
int PreviousNode();
```

*Part-oriented data structure*

Part-oriented data structures contain net information about flat designs organized so IFORM can access data from a part perspective.

You can include functions that direct IFORM to create and use a part-oriented data structure. When creating a part-oriented data structure, include these functions in the format file:

- ❖ Include the function **RecordNode()** in the **WriteNet()** function.
- ❖ Include the function **AddSignalName()** in the **HandleNodeName()** function.
- ❖ Include the function **CreatePartDatabase()** in the **WriteHeader()** function.

These functions access part-oriented data structures:

```
int EndNode();
int GetIndex( part_symbol );
SetFirst( part_symbol );
int SetIndexByRef( user_symbol );
int SetNext( part_symbol );
int SetPrevious( part_symbol );
int SetToIndex(part_symbol, variable );
```

With one exception, you can use all other functions with part-oriented netlists: using **SortByNumber** scrambles the data, making the part-oriented data structure invalid.

**Instance files**

The instance file (\*.INS), part of the intermediate netlist structure, contains a list of all parts and instances in a design. Each instance file is comprised of instances that, in turn, are comprised of standard symbols. At any given time, one instance is current.

IFORM accesses the instance file automatically; HFORM can create an instance file and access it if you use the function **MakeInstanceFile()**. Once HFORM creates an instance file, it can use all the instance file functions.

These functions access instance files:

```
LoadFieldString( string_symbol );
int LoadFirstPin();
int LoadInstance();
int LoadPin();
MakeInstanceFile();
int NextAccessType();
int NextInstance();
RewindInstanceFile();
SetAccessType( string_symbol );
SortByNumber();
```

---

## Traversal functions

Traversal functions allow you to control how HFORM traverses a design. HFORM recognizes two variations of a traversal function: **SetTraversal( string\_constant )** and **SetTraversal( user\_symbol )**.

---

## Pipe file functions

IFORM can access the pipe file (\*.PIP) of the intermediate netlist structure for pipe information, and HFORM can access the incremental connectivity database for pipe information.

When using HFORM, the .PIP file can only be accessed during the **PostProcess()** function.

The pipe file functions are:

```
int AccessKeyWord( string_constant );
int AccessKeyWord( standard_symbol );
int AccessKeyWord( user_symbol );
int FirstPipe();
int IsKeyWord();
int NextKeyWord();
int NextPipe();
```

For more about these functions, see the section *Function reference*. See also the function **PostProcess()**.

## General functions

General functions are OrCAD-defined functions. Some access data structures and some do not. The general functions are:

```
AddSymbol( string_constant );
ClearSymbolicStrings();
int CompareSymbol( symbol, symbol );
ConcatFile( file_index, file_index );
CopySymbol( symbol, user_symbol );
ExceptionsFor( string_constant, user_symbol );
int FindSymbolChar( variable, user_symbol );
int GetStandardSymbol( standard_symbol );
int GetSymbolChar( variable, user_symbol );
MakeLocalSignal( string_constant );
int PackString( integer_constant, integer_constant,
               user_symbol, user_symbol );
int PackString( variable, variable, user_symbol, user_symbol
               );
PadSpaces( user_symbol, integer_constant );
PadSpaces( user_symbol, variable );
PutSymbolChar( variable, integer_constant, user_symbol );
PutSymbolChar( variable, variable, user_symbol );
SetAccessType( user_symbol );
SetCharSet( string_constant );
SetNumberWidth( integer_constant );
SetNumberWidth( variable );
SetPinMap( integer_constant, string_constant );
SetPinMap( variable, string_constant );
SetSymbol( user_symbol, string_constant );
int SwitchIsSet( string_constant );
int SymbolInCharSet( user_symbol );
int SymbolLength( symbol );
ToUpper( user_symbol );
WriteCrLf( file_index );
WriteMap( file_index, integer_constant );
WriteMap( file_index, variable );
WriteString( file_index, string_constant );
WriteSymbol( file_index, user_symbol );
WriteStdSymbol( file_index, standard_symbol );
```

For more about these functions and symbols, see the reference portion of this appendix.

---

## C-language functions

You can use these C-language functions in netlist format files:

```
int getche();
int getnum();
int print( variable );
int print( string_constant );
int putch( variable )
int puts ( string_constant );
```

---

## Switches

You can define switches, called “options” in the ESP design environment, that provide options for creating custom netlists. Then when you configure IFORM and HFORM, you select a file format and select options for that format. The first comment in the .CF or .CH file names switches and defines descriptions that display on the configuration screen. Then you use `SwitchIsSet()` to find out if IFORM or HFORM was called with the switch set.

The switch names can be uppercase or lowercase. However, IFORM and HFORM convert all lowercase switch names to uppercase.

△ *NOTE: Do not use these switches that IFORM or HFORM already use: /B, /Q, and /Z.*



## Standard symbol reference

Symbols are names associated with an array of characters that is accessed via the symbol name. Functions use symbolic information as the main method for accessing data. Standard symbols may be accessed and printed but may not be changed.

This section lists standard symbols of four classifications:

- ❖ **Symbols for HFORM** that you use only for hierarchical format files.
- ❖ **Title block symbols** that contain information from worksheet title blocks.
- ❖ **User symbols** that act as standard symbols.
- ❖ **Standard symbols** that contain information about parts, pins, nets, and children, text from the pipe file, and indexes.

**AddressLine1–  
AddressLine4**

*title block  
symbol*

String. The address lines from the worksheet.

**DateString**

*title block  
symbol*

String. The date string from the worksheet.

**DocumentNumber**

*title block  
symbol*

String. The document number from the worksheet.

**ExitType**

*user symbol*

String. This is a reserved symbol in the user symbol space since this symbol may be set. The symbol is read after the formatting loop is complete.

- ❖ If the symbol contains “W,” then there were warnings found during the format process.
- ❖ If the symbol contains “E,” then errors were found during the format process.

IFORM and HFORM each have the `Ignore warnings` option on the **Local Configuration** screen. This table shows the results of combinations of `ExitType` values and option settings:

| <i>ExitType contains</i> | <i>Ignore warnings option</i> | <i>Result</i>             |
|--------------------------|-------------------------------|---------------------------|
| W                        | ON                            | Exits                     |
| W                        | OFF                           | Exits reporting a warning |
| E                        | ON or OFF                     | Exits reporting an error  |
| <i>nothing</i>           | ON or OFF                     | Exits                     |

*Results of combinations of ExitType and Ignore warnings options.*

You use this symbol when you define error or warning messages for a format file. You do not need to use the `AddSymbol()` function for `ExitType`; it is already defined.

The function `ClearSymbolicStrings()` does not clear `ExitType`.

|                                  |                         |  |
|----------------------------------|-------------------------|--|
| <b>FieldString1–FieldString8</b> | <i>standard symbol</i>  | String. Field strings for an instance of a part. A <code>LoadInstance()</code> call must precede use of this symbol. |
| <b>FileName</b>                  | <i>standard symbol</i>  | String. The file that is being processed.  |
| <b>Keyword</b>                   | <i>standard symbol</i>  | String. Contains the current keyword from the pipe file.   |
| <b>LastFile</b>                  | <i>symbol for HFORM</i> | Returns 1 if the current file is the last file in the file stack, otherwise returns 0.                               |

|                          |                         |   |
|--------------------------|-------------------------|---|
| <b>LibraryNameString</b> | <i>standard symbol</i>  | String. Contains the library name for the current part.   |
| <b>LocalSignal</b>       | <i>user symbol</i>      | A user symbol containing a local signal name constructed from a specified <b>string_constant</b> and the standard symbols <b>SignalNameString</b> and <b>SheetNumber</b> . The function that creates this user symbol is <b>MakeLocalSignal()</b> . You do not need to use <b>AddSymbol()</b> to define this symbol.  |
| <b>LookupNameString</b>  | <i>standard symbol</i>  | String. Contains the name used to look up the current part in the part library indicated by <b>LibraryNameString</b> .  |
| <b>ModuleName</b>        | <i>standard symbol</i>  | String. This is the module name obtained from the module value field.   |
| <b>NetCode</b>           | <i>symbol for HFORM</i> | Character. Contains the current net node type. It may be one of: <ul style="list-style-type: none"> <li>L Label node—a node labeled on a worksheet</li> <li>P Port node—a node connected to a module port on a worksheet</li> <li>S Power node—a node connected to power or ground</li> <li>N Node—an unlabeled node connected to something other than a module port, power, or ground</li> <li>U Unconnected node—a node unconnected to anything on a worksheet</li> </ul> <p>This is only loaded when a net is made current in HFORM. It is the <b>NetType</b> obtained from scanning the nodes on the net as though a “link” had been run for the net.</p> |

|                      |                           |   |
|----------------------|---------------------------|---|
| <b>NetNameString</b> | <i>symbol for HFORM</i>   | String. The name of the current net. Since a net for HFORM is composed of all the nodes, including multiple ports or labels if present, the <b>NetNameString</b> is built as it would have been if the net had been "linked". This is a unique name and is loaded if the <b>NetType</b> is "L," "P," or "S."  |
| <b>NetNumber</b>     | <i>standard symbol</i>    | Unsigned integer. The current net number. IFORM and HFORM assign unique net numbers to all nodes in a net.  |
| <b>NetType</b>       | <i>symbol for HFORM</i>   | Character. Contains the signal type. This may be one of:<br><br>0 Unspecified<br>1 Output<br>2 Input<br>3 Bidirectional<br>255 Not Used (OFFH)<br><br>HFORM loads <b>NetType</b> only when a net is made current.   |
| <b>Organization</b>  | <i>title block symbol</i> | String. The organization name string from the worksheet.  |
| <b>PartIndex</b>     | <i>standard symbol</i>    | Unsigned integer. The index corresponds to the parts-per-package number of the current part. This value represents the annotated suffix, with 0 = "A", 1 = "B", and so on. The value is loaded when a signal is made current.<br><br>For a part-oriented netlist, <b>PartIndex</b> is loaded with the index into the part list when a part is made current. Since parts are assumed to have unique references, the <b>PartIndex</b> is unique for each part in the package. |

|                        |                        |   |     |   |       |  |   |               |  |   |        |  |   |                |  |   |         |  |   |      |  |   |              |  |   |       |               |   |             |  |   |        |  |   |       |  |   |               |
|------------------------|------------------------|---|-----|---|-------|--|---|---------------|--|---|--------|--|---|----------------|--|---|---------|--|---|------|--|---|--------------|--|---|-------|---------------|---|-------------|--|---|--------|--|---|-------|--|---|---------------|
| <b>PartName</b>        | <i>standard symbol</i> | String. This is the part name obtained from the part value field.   |     |   |       |  |   |               |  |   |        |  |   |                |  |   |         |  |   |      |  |   |              |  |   |       |               |   |             |  |   |        |  |   |       |  |   |               |
| <b>PinIndex</b>        | <i>standard symbol</i> | Unsigned integer. If <b>PinNameString</b> is "OUT" or "FBK", then the index is set to 0FFFFH to accommodate Altera's ADF netlist format. Otherwise, the integer is encoded with the most significant four bits containing which device in the package this pin belongs to and the lower twelve bits containing the pin definition offset. The value of interest is 0FFFFH or not 0FFFFH.  |     |   |       |  |   |               |  |   |        |  |   |                |  |   |         |  |   |      |  |   |              |  |   |       |               |   |             |  |   |        |  |   |       |  |   |               |
| <b>PinNameString</b>   | <i>standard symbol</i> | String. Contains the pin name string for the current instance of a node.  |     |   |       |  |   |               |  |   |        |  |   |                |  |   |         |  |   |      |  |   |              |  |   |       |               |   |             |  |   |        |  |   |       |  |   |               |
| <b>PinNumberString</b> | <i>standard symbol</i> | String. Contains the string representation of the pin number for the current instance of a node.  |     |   |       |  |   |               |  |   |        |  |   |                |  |   |         |  |   |      |  |   |              |  |   |       |               |   |             |  |   |        |  |   |       |  |   |               |
| <b>PinType</b>         | <i>standard symbol</i> | Character. Contains one of these types for pins, ports and signals, or sheets: <table border="0" style="margin-left: 2em;"> <tr> <td>Pin</td> <td>0</td> <td>Input</td> </tr> <tr> <td></td> <td>1</td> <td>BiDirectional</td> </tr> <tr> <td></td> <td>2</td> <td>Output</td> </tr> <tr> <td></td> <td>3</td> <td>Open Collector</td> </tr> <tr> <td></td> <td>4</td> <td>Passive</td> </tr> <tr> <td></td> <td>5</td> <td>Hi-Z</td> </tr> <tr> <td></td> <td>6</td> <td>Open Emitter</td> </tr> <tr> <td></td> <td>7</td> <td>Power</td> </tr> <tr> <td>Port &amp; signal</td> <td>0</td> <td>Unspecified</td> </tr> <tr> <td></td> <td>1</td> <td>Output</td> </tr> <tr> <td></td> <td>2</td> <td>Input</td> </tr> <tr> <td></td> <td>3</td> <td>BiDirectional</td> </tr> </table> | Pin | 0 | Input |  | 1 | BiDirectional |  | 2 | Output |  | 3 | Open Collector |  | 4 | Passive |  | 5 | Hi-Z |  | 6 | Open Emitter |  | 7 | Power | Port & signal | 0 | Unspecified |  | 1 | Output |  | 2 | Input |  | 3 | BiDirectional |
| Pin                    | 0                      | Input   |     |   |       |  |   |               |  |   |        |  |   |                |  |   |         |  |   |      |  |   |              |  |   |       |               |   |             |  |   |        |  |   |       |  |   |               |
|                        | 1                      | BiDirectional   |     |   |       |  |   |               |  |   |        |  |   |                |  |   |         |  |   |      |  |   |              |  |   |       |               |   |             |  |   |        |  |   |       |  |   |               |
|                        | 2                      | Output  |     |   |       |  |   |               |  |   |        |  |   |                |  |   |         |  |   |      |  |   |              |  |   |       |               |   |             |  |   |        |  |   |       |  |   |               |
|                        | 3                      | Open Collector  |     |   |       |  |   |               |  |   |        |  |   |                |  |   |         |  |   |      |  |   |              |  |   |       |               |   |             |  |   |        |  |   |       |  |   |               |
|                        | 4                      | Passive   |     |   |       |  |   |               |  |   |        |  |   |                |  |   |         |  |   |      |  |   |              |  |   |       |               |   |             |  |   |        |  |   |       |  |   |               |
|                        | 5                      | Hi-Z  |     |   |       |  |   |               |  |   |        |  |   |                |  |   |         |  |   |      |  |   |              |  |   |       |               |   |             |  |   |        |  |   |       |  |   |               |
|                        | 6                      | Open Emitter  |     |   |       |  |   |               |  |   |        |  |   |                |  |   |         |  |   |      |  |   |              |  |   |       |               |   |             |  |   |        |  |   |       |  |   |               |
|                        | 7                      | Power   |     |   |       |  |   |               |  |   |        |  |   |                |  |   |         |  |   |      |  |   |              |  |   |       |               |   |             |  |   |        |  |   |       |  |   |               |
| Port & signal          | 0                      | Unspecified   |     |   |       |  |   |               |  |   |        |  |   |                |  |   |         |  |   |      |  |   |              |  |   |       |               |   |             |  |   |        |  |   |       |  |   |               |
|                        | 1                      | Output  |     |   |       |  |   |               |  |   |        |  |   |                |  |   |         |  |   |      |  |   |              |  |   |       |               |   |             |  |   |        |  |   |       |  |   |               |
|                        | 2                      | Input   |     |   |       |  |   |               |  |   |        |  |   |                |  |   |         |  |   |      |  |   |              |  |   |       |               |   |             |  |   |        |  |   |       |  |   |               |
|                        | 3                      | BiDirectional   |     |   |       |  |   |               |  |   |        |  |   |                |  |   |         |  |   |      |  |   |              |  |   |       |               |   |             |  |   |        |  |   |       |  |   |               |

|                         |                           |   |   |                |
|-------------------------|---------------------------|---|---|----------------|
|                         |                           | Sheet   | 0 | Unspecified    |
|                         |                           |   | 1 | Output         |
|                         |                           |   | 2 | Input          |
|                         |                           |   | 3 | BiDirectional  |
|                         |                           |   | 4 | Open collector |
|                         |                           |   | 5 | Passive        |
|                         |                           |   | 6 | Hi-Z           |
|                         |                           |   | 7 | Open emitter   |
|                         |                           |   | 8 | Power          |
| <b>PipeLine</b>         | <i>standard symbol</i>    | String. This contains the current line in the pipe file.  |   |                |
| <b>ReferenceString</b>  | <i>standard symbol</i>    | String. Contains the reference designator for either the instance of a part or of a node.   |   |                |
| <b>Revision</b>         | <i>title block symbol</i> | String. The revision number from the worksheet.   |   |                |
| <b>SheetNumber</b>      | <i>title block symbol</i> | Unsigned integer. Contains the current worksheet number. In IFORM, if the current <b>TypeCode</b> is "L", <b>SheetNumber</b> reflects the number of the sheet containing the signal. If <b>TypeCode</b> is any other value, <b>SheetNumber</b> may not be accurate because it is updated only if the current signal net has a label.<br><br>In HFORM, <b>SheetNumber</b> is always correct. |   |                |
| <b>SheetSize</b>        | <i>title block symbol</i> | Character. Contains the size of the worksheet.  |   |                |
| <b>SignalNameString</b> | <i>standard symbol</i>    | String. May contain a signal name. If <b>TypeCode</b> is "L", "P", or "S", then <b>SignalNameString</b> contains the signal name. The <b>SignalNameString</b> is empty otherwise.   |   |                |

|                    |                           |   |
|--------------------|---------------------------|---|
| <b>SignalType</b>  | <i>standard symbol</i>    | <p>Character. Contains the signal type. The signal types are:</p> <ul style="list-style-type: none"> <li>0 Unspecified</li> <li>1 Output</li> <li>2 Input</li> <li>3 Bidirectional</li> </ul>   |
| <b>TimeStamp</b>   | <i>standard symbol</i>    | <p>String. Contains the hexadecimal time stamp for the part. The hexadecimal time stamp has no suffix to indicate the number is hexadecimal.</p>  |
| <b>TitleString</b> | <i>title block symbol</i> | <p>String. Contains the title string from the worksheet.</p>  |
| <b>TotalSheets</b> | <i>title block symbol</i> | <p>Unsigned integer. Contains the total number of sheets as shown on the worksheet.</p>   |
| <b>TypeCode</b>    | <i>standard symbol</i>    | <p>Character. Contains the current net node type. The net node types are:</p> <ul style="list-style-type: none"> <li>L Label node</li> <li>S Power node</li> <li>P Port node</li> <li>N Node containing no symbolic name</li> <li>U Unconnected node</li> </ul> |

---

## Type definition reference

Type definitions are constants or variables that you supply for functions in the format file. This section lists the type definitions you use in format files.

|                        |  |  |             |          |           |             |
|------------------------|--|--|-------------|----------|-----------|-------------|
| <b>access_constant</b> | <i>type definition for general functions</i> | <p>A subset of <b>string_constant</b>, this must be one of these four access fields:</p> <table border="0" style="margin-left: 20px;"> <tr> <td>"PARTVALUE"</td> <td>"LOOKUP"</td> </tr> <tr> <td>"LIBRARY"</td> <td>"REFERENCE"</td> </tr> </table> <p>See <b>SetAccessType()</b> in the section <i>Function reference</i>.</p> | "PARTVALUE" | "LOOKUP" | "LIBRARY" | "REFERENCE" |
| "PARTVALUE"            | "LOOKUP"                                     |  |             |          |           |             |
| "LIBRARY"              | "REFERENCE"                                  |  |             |          |           |             |

|                         |   |  |
|-------------------------|---|--|
| <b>file_index</b>       | <i>type<br/>definition<br/>for general<br/>functions</i>            | An integer constant that indicates to which output file IFORM or HFORM writes. Index 0 is reserved for output to the screen while index 1 and index 2 refer to the files specified on the <b>Local Configuration</b> screen. Index 3 refers a scratch file that is deleted after IFORM or HFORM are finished. The default is 0. A file index may also be a variable. |
| <b>format_constant</b>  | <i>type<br/>definition</i>  | <p>One of these three values:</p> <p>ADF    A standard known as both the Altera Design Format and Intel's Advanced Design File.</p> <p>MOD    OrCAD's Programmable Logic Device Modeling Tools.</p> <p>EDIF    Electronic Design Intercange Format</p> <p>See <b>ExceptionsFor()</b> in the section <i>Function reference</i>.</p>                                   |
| <b>integer_constant</b> | <i>type<br/>definition<br/>for general<br/>functions</i>            | A whole number in the range -32,678 to 32,767.   |
| <b>part_symbol</b>      | <i>type<br/>definition<br/>for part-<br/>oriented<br/>functions</i> | <p>A subset of <b>user_symbol</b> for use with functions for part-oriented netlists. The following tables are the source of all the standard symbols when writing format files for creating part-oriented netlists.</p> <p><b>SIGNALS</b>    The table of all signal names and types. The net contains one signal name and type for each connected node.</p>         |



|       |   |
|-------|---|
| PARTS | The table of all parts found in the instance file. Each part entry is comprised of the standard symbols <b>ReferenceString</b> , <b>PartName</b> , and <b>ModuleName</b> . A one-to-one correspondence exists between entries in the PARTS and NETS tables. |
| NETS  | The table of all nets. The table entry points to all the pins, or nodes, on a part that are electrically connected to another node.   |
| NODES | The list of all nodes on a given net. Each pin on a part may occur in a net. The electrical node is identified by the SIGNAL name.  |
| ALL   | The list of all signals, parts, nets, and nodes.  |

This symbol is one of the thirty-six you can define. However, to access a part-oriented database, **part\_symbol** must contain one of the five table names listed above.

|                        |  |   |
|------------------------|--|---|
| <b>standard_symbol</b> | <i>type definition for general functions</i> | One of the standard symbols listed in the section <i>Symbol reference</i> . |
| <b>string_constant</b> | <i>type definition for general functions</i> | A string enclosed in quotation marks.                                       |
| <b>symbol</b>          | <i>type definition for general functions</i> | Either a <b>standard_symbol</b> or a <b>user_symbol</b> .                   |

|                           |  |   |
|---------------------------|--|---|
| <b>traversal_constant</b> | <i>type<br/>definition<br/>for general<br/>functions</i> | A subset of <b>string_constant</b> , this must be either "ROOT" or "LEAF". See <b>SetTraversal()</b> in the section <i>Function reference</i> . |
| <b>user_symbol</b>        | <i>type<br/>definition<br/>for general<br/>functions</i> | A user-defined symbol.  |
| <b>variable</b>           | <i>type<br/>definition<br/>for general<br/>functions</i> | An integer defined with an <b>int</b> statement in the range -32,768 to 32,767.   |

---

## Function reference

This portion of the appendix lists all the standard functions that IFORM and HFORM recognize in format files. The functions appear in alphabetical order, disregarding any **int** prefixes. The descriptions include a function classification and definition.

|   |  |   |
|---|--|---|
| <b>int AccessChild<br/>( user_symbol );</b>       | <i>child data<br/>structure<br/>function</i> | Uses the input <b>user_symbol</b> containing a valid <b>PartName</b> to access the child that matches the name. The function returns 1 on success or 0 otherwise.   |
| <b>int AccessKeyWord<br/>( string_constant );</b> | <i>pipe file<br/>functions</i>               | Uses the input <b>string_constant</b> or <b>symbol</b> containing a pipe symbol keyword to make the next line in the file containing that keyword current. <b>KeyWord</b> and <b>PipeLine</b> are both loaded. The function returns 1 on success or 0 otherwise. If the function returns 0, then no action has been taken—the position in the file is the same as before the call and <b>KeyWord</b> and <b>PipeLine</b> are the same as before the call. |
| <b>int AccessKeyWord<br/>( standard_symbol );</b> |  |   |
| <b>int AccessKeyWord<br/>( user_symbol );</b>     |  |   |

|   |   |   |
|---|---|---|
| <p><b>int AccessPart</b><br/>( <b>user_symbol</b> );</p>                      | <p><i>part data<br/>structure<br/>function</i></p>        | <p>Makes the part that matches the input user symbol—assumed to contain a valid <b>ReferenceString</b>—current. The function loads the associated standard symbols and returns 1 on success or 0 if the input reference was not found. Use this function only when creating format files for hierarchical netlists.</p> |
| <p><b>AddSignalName();</b></p>  | <p><i>part-<br/>oriented<br/>netlist<br/>function</i></p> | <p>Adds the current <b>SignalNameString</b> and <b>SignalType</b> to the signal table. If the <b>SignalNameString</b> is empty, the <b>NetNumber</b> is used instead. This function is required in formats for part-oriented netlists and should be used within the <b>HandleNodeName()</b> required function.</p>      |
| <p><b>AddSymbol</b><br/>( <b>string_constant</b> );</p>                       | <p><i>general<br/>function</i></p>                        | <p>Adds the symbol name indicated by <b>string_constant</b> to the list of available symbols. You must use this function to create new user symbols before you use the symbols.</p>   |
| <p><b>int</b><br/><b>ChildPinCount();</b></p>                                 | <p><i>child data<br/>structure<br/>function</i></p>       | <p>Returns the total number of sheet pins on the current child.</p>   |
| <p><b>ClearSymbolic</b><br/><b>Strings();</b></p>                             | <p><i>general<br/>function</i></p>                        | <p>Clears the list of available user symbols. All user symbols and their contents are erased. See also <b>AddSymbol()</b> in the section <i>Function reference</i>.</p>   |
| <p><b>int</b><br/><b>CompareSymbol</b><br/>( <b>symbol, symbol</b> );</p>     | <p><i>general<br/>function</i></p>                        | <p>Returns 0 if the values represented by the two input symbols are the same and 1 if they either are not the same or are not both strings or both numbers.</p>   |
| <p><b>ConcatFile</b><br/>(<b>file_index_1,</b><br/><b>file_index_2</b> );</p> | <p><i>general<br/>function</i></p>                        | <p>Places the contents of the file specified by <b>file_index_2</b> at the end of the file specified by <b>file_index_1</b>. The type definitions <b>file_index_1</b> and <b>file_index_2</b> must be either 1, 2, or 3. See <b>file_index</b>.</p>   |

|   |   |   |
|---|---|---|
| <p><b>CopySymbol</b><br/>( <b>symbol</b>,<br/><b>user_symbol</b> );</p>               | <p><i>general<br/>function</i></p>                        | <p>Copies the contents of the symbolic string indicated by <b>symbol</b> into the indicated <b>user_symbol</b>.</p>   |
| <p><b>CreatePart<br/>Database();</b></p>  | <p><i>part-<br/>oriented<br/>netlist<br/>function</i></p> | <p>Uses the instance file to create a part-oriented database IFORM can use. You call this function within the required function <b>WriteHeader()</b>.</p>   |
| <p><b>int EndNode();</b></p>  | <p><i>part-<br/>oriented<br/>netlist<br/>function</i></p> | <p>Returns 1 if the current node in the NETS table is <b>EndNode</b> and 0 otherwise. For information about the NETS table, see <b>part_symbol</b> in the section <i>Type definition reference</i>.</p>   |
| <p><b>ExceptionsFor</b><br/>( <b>format_constant</b>,<br/><b>user_symbol</b> );</p>   | <p><i>general<br/>function</i></p>                        | <p>Modifies <b>user_symbol</b> according to the format specified in <b>format_constant</b>. IFORM sets <b>user_symbol</b> to the appropriate characters for three different standards: ADF, MOD, and EDIF. For example, to have IFORM parse symbols and convert them to symbols that meet EDIF standards, write this:</p> <pre>ExceptionsFor("EDIF", TempStr )</pre>                  |
| <p><b>int<br/>FindSymbolChar</b><br/>( <b>variable</b>,<br/><b>user_symbol</b> );</p> | <p><i>general<br/>function</i></p>                        | <p>Finds the indicated <b>variable</b> in the string represented by <b>user_symbol</b>. The index into the string of the first occurrence of the character is returned if the character was found, otherwise 0FFFFH (65535) is returned.</p> <p>For these and other functions that access specified locations in a string, the first character in the string is at location zero.</p> |

|                          |   |   |
|--------------------------|---|---|
| <b>int FirstChild();</b> | <i>child data structure function</i>        | Makes the first child in a child data structure current. The first sheet net, <b>ReferenceString</b> , <b>TimeStamp</b> , <b>PartName</b> , <b>PinNameString</b> , and <b>PinType</b> are also made current. The function returns 1 on success or 0 if the first child is empty. An empty first child means that the incremental netlist file is a leaf node containing no children.  |
| <b>FirstChildPin();</b>  | <i>child data structure function</i>        | Makes the first sheet net current and loads the associated standard symbols.  |
| <b>FirstNet();</b>       | <i>net-oriented data structure function</i> | Makes the first net the current net. The first node on the net is made current and the associated standard symbols are loaded. Use this function only when creating format files for hierarchical netlists.   |
| <b>FirstNode();</b>      | <i>net-oriented data structure function</i> | Makes the first node on the current net current and loads the associated standard symbols. Use this function only when creating format files for hierarchical netlists.   |
| <b>int FirstPart();</b>  | <i>part data structure function</i>         | Makes the first part current and loads the associated standard symbols. The first pin of the part also becomes current. The function returns 1 on success or 0 if there are no parts in this incremental netlist file. A file containing no parts occurs when the schematic is composed only of children or when the schematic is empty. In both cases, <b>FirstPart()</b> and <b>FirstChild()</b> return 0. Use this function only when creating format files for hierarchical netlists. |
| <b>FirstPin();</b>       | <i>part data structure function</i>         | Makes the first pin of the current part current. The associated standard symbols are loaded. Use this function only when creating format files for hierarchical netlists.   |

|  |   |  |
|--|---|--|
| <pre>int FirstPipe();</pre>  | <p><i>pipe file<br/>function</i></p>                      | <p>Sets the seek pointer to either zero or the start of the pipe file. This function returns 1 on success or 0 otherwise. On success, the <b>KeyWord</b> and <b>PipeLine</b> are loaded.</p>   |
| <pre>int getche();</pre>   | <p><i>C-language<br/>function</i></p>                     | <p>Returns a character from the keyboard.</p>  |
| <pre>int GetIndex<br/>( part_symbol );</pre>                           | <p><i>part-<br/>oriented<br/>netlist<br/>function</i></p> | <p>Returns the current index for the table indicated by <b>part_symbol</b>. For example:</p> <pre>Get Index ( SIGNALS );</pre> <p>For a discussion of the tables, see the type definition <b>part_symbol</b>.</p>  |
| <pre>int getnum();</pre>   | <p><i>C-language<br/>function</i></p>                     | <p>Returns an integer that is input from the keyboard. This function does not check the input to make sure it is valid.</p>  |
| <pre>int<br/>GetStandardSymbo<br/>l<br/>( standard_symbol<br/>);</pre> | <p><i>general<br/>function</i></p>                        | <p>Returns the value associated with <b>standard_symbol</b>. If <b>standard_symbol</b> is a string, then 0 is returned. Otherwise the integer or the char value cast as an integer is returned.</p>  |
| <pre>int GetSymbolChar<br/>( variable,<br/>user_symbol );</pre>        | <p><i>general<br/>function</i></p>                        | <p>Returns the character at the location <b>variable</b> in the string associated with <b>user_symbol</b>. For example, if <b>user_symbol</b> is <b>Part</b> and contains <b>PLD22V10</b>, this function returns <b>V</b>:</p> <pre>GetSymbolChar ( 5, Part );</pre> <p>For this and other functions that access specified locations in a string, the first character in the string is at location zero.</p> |

**HandleNodeName** (**());** *required function for IFORM* Allows access to several symbols, depending on which type of net it encounters. When IFORM reads the \*.RES file and encounters a net, it calls this function. This table lists node types and the symbols **HandleNodeName()** can access:

| <i>Net type</i> | <i>Symbols accessed by HandleNodeName()</i>              |
|-----------------|--|
| Label (L)       | <b>TypeCode, NetNumber, SignalType, SignalNameString</b> |
| Port (P)        | <b>TypeCode, NetNumber, SignalType, SignalNameString</b> |
| Power (S)       | <b>TypeCode, NetNumber, SignalType, SignalNameString</b> |
| Node (N)        | <b>TypeCode, NetNumber</b>                               |
| Unconnected (U) | <b>TypeCode, NetNumber</b>                               |

**Initialize();** *required function for IFORM and HFORM* IFORM and HFORM call this function first. Here you can initialize symbols and variables, define character sets, write headers, and set number widths.

**int IsKeyWord();** *pipe file function* Returns 1 if the current standard symbol **PipeLine** contains a keyword and 0 if it does not.

**LoadFieldString ( user\_symbol );** *instance file function* Uses the input **user\_symbol** that represents a part reference and loads associated standard symbols from the instance file. The function returns 1 on success or 0 on end of file.

**int LoadFirstPin();** *instance file function* Loads the first pin in the current instance. This function must follow a **LoadInstance()** call. The function loads **PinNameString**, **PinNumberString**, and **PinType**. The function returns 1 on success or 0 otherwise.

---

|   |                                   |   |
|---|-----------------------------------|---|
| <code>int LoadInstance();</code>                      | <i>instance file<br/>function</i> | Loads the standard symbols from the current entry in the instance file. This function returns 1 if the values were loaded correctly and 0 on end of file. This function may be called in a conditional statement.   |
| <code>int LoadPin();</code>                           | <i>instance file<br/>function</i> | Loads the next pin in the current instance. A <code>LoadInstance()</code> call must precede this function. The function loads <code>PinNameString</code> , <code>PinNumberString</code> , <code>PinType</code> , <code>LibraryNameString</code> , and <code>LookupNameString</code> . The function returns 1 on success or 0 otherwise.   |
| <code>MakeInstanceFile<br/>();</code>                 | <i>instance file<br/>function</i> | Creates an instance file for HFORM. This function must be called in the <code>Initialize()</code> loop. This function is valid only in *.CH format files.   |
| <code>MakeLocalSignal<br/>( string_constant );</code> | <i>general<br/>function</i>       | Uses the current standard symbols to construct a local signal name and places it in the user symbol <code>LocalSignal</code> . <code>LocalSignal</code> is built by concatenating <code>SignalNameString</code> , the input <code>string_constant</code> , and the <code>SheetNumber</code> . The current number width—set with <code>SetNumberWidth()</code> —determines the width of <code>LocalSignal</code> . <code>LocalSignal</code> is one of the thirty-six user symbols. |
| <code>int<br/>NextAccessType<br/>();</code>           | <i>instance file<br/>function</i> | Makes the next instance that contains an access field different than the current access field current. The function returns 1 on success or 0 otherwise. When you use this function with <code>SetAccessType()</code> , <code>SetAccessType()</code> should occur first. For a list of the access fields, see <code>access_constant</code> in the section <i>Type definition reference</i> .  |



|                                      |   |  |
|--------------------------------------|---|--|
| <code>int NextChild();</code>        | <i>child data structure function</i>        | Makes the next child current and loads the associated standard symbols. This function returns 1 on success or 0 at end of list. This function must follow the <b>FirstChild()</b> function.  |
| <code>int NextChildPin();</code>     | <i>child data structure function</i>        | Makes the next sheet net current. This function returns 1 on success or 0 at end of list. This function must follow the <b>FirstChildPin()</b> function.   |
| <code>int NextInstance();</code>     | <i>instance file function</i>               | Makes the next instance that contains an access field matching the current access field current. If the current access field is not set, the next instance becomes current. When you use this function with the <b>SetAccessType()</b> function, <b>SetAccessType()</b> should precede <b>NextInstance()</b> . For a list of the access fields, see <code>access_constant</code> in the section <i>Type definition reference</i> . |
| <code>int NextKeyWord<br/>();</code> | <i>pipe file function</i>                   | Accesses the next keyword in the pipe file. This function returns 1 on success or 0 otherwise. If the function returns 0, then no action is taken. If the function returns 1, then <b>KeyWord</b> contains the next keyword and <b>PipeLine</b> contains the line in which the keyword appears.  |
| <code>int NextNet();</code>          | <i>net-oriented data structure function</i> | Makes the next net current and makes the associated standard symbols current. This function returns 1 on success or 0 at end of list. The <b>FirstNet()</b> function must precede <b>NextNet()</b> . Use this function only when creating format files for hierarchical netlists.  |

|                        |   |   |
|------------------------|---|---|
| <b>int NextNode();</b> | <i>net-oriented data structure function</i> | Makes the next node current and loads the associated standard symbols. This function returns 1 on success or 0 at end of list. The <b>FirstNode()</b> function must precede <b>NextNode()</b> . Use this function only when creating format files for hierarchical netlists.                  |
| <b>int NextPart();</b> | <i>part data structure function</i>         | Makes the next part current and loads the associated standard symbols. This function returns 1 on success or 0 at end of list. The <b>FirstPart()</b> function must precede <b>NextPart()</b> . Use this function only when creating format files for hierarchical netlists.                  |
| <b>int NextPin();</b>  | <i>part data structure function</i>         | Makes the next pin on the current part current and loads the associated standard symbols. This function returns 1 on success or 0 on end of list. The <b>FirstPin()</b> function must precede <b>NextPin()</b> . Use this function only when creating format files for hierarchical netlists. |
| <b>int NextPipe();</b> | <i>pipe file function</i>                   | Makes the next pipe line current and loads <b>PipeLine</b> and <b>KeyWord</b> . This function returns 1 on success or 0 otherwise. The <b>FirstPipe()</b> function must precede <b>NextPipe()</b> .   |

|   |  |   |
|---|--|---|
| <pre>int PackString ( integer_constant,   integer_constant,   user_symbol,   user_symbol );</pre> | <p><i>general<br/>functions</i></p>                | <p>Deletes a substring of the first <b>user_symbol</b>, starting with the character in the space specified by the first <b>integer_constant</b> and ending with the second <b>integer_constant</b>. Then it places the deleted substring into the second <b>user_symbol</b>. This function returns 1 on success or 0 otherwise. For example:</p> <pre>PackString(6, 4, SigNameStr, Str);</pre> <p>The second variation of the function behaves the same except the spaces are defined by variables. For example:</p> <pre>PackString(pos, len, SigNameStr, Str);</pre> <p>For these and other functions that access specified locations in a string, the first character in the string is at location zero.</p> |
| <pre>PadSpaces ( user_symbol,   integer_constant );</pre>   | <p><i>general<br/>functions</i></p>                | <p>Sets the length of <b>user_symbol</b> to the length specified by <b>integer_constant</b> or <b>variable</b>. The function either pads the string with spaces or truncates it.</p>  |
| <pre>PadSpaces ( user_symbol,   variable );</pre>   | <p><i>general<br/>functions</i></p>                | <p>Sets the length of <b>user_symbol</b> to the length specified by <b>integer_constant</b> or <b>variable</b>. The function either pads the string with spaces or truncates it.</p>  |
| <pre>int PinCount();</pre>  | <p><i>part data<br/>structure<br/>function</i></p> | <p>Returns the number of pins on the current part. Use this function only when creating format files for hierarchical netlists.</p>   |
| <pre>PostFile();</pre>  | <p><i>required<br/>function for<br/>HFORM</i></p>  | <p>HFORM calls this function after parsing the current worksheet. All the data structures are loaded and available for use.</p>   |
| <pre>PostProcess();</pre>   | <p><i>required<br/>function for<br/>HFORM</i></p>  | <p>HFORM calls this function after reading all the worksheets in the design. The pipe file functions are valid during this function call. Pipes are considered a post processing function.</p>  |

|   |  |   |
|---|--|---|
| <pre>PreFile();</pre>   | <p><i>required<br/>function for<br/>HFORM</i></p>              | <p>HFORM calls this function before processing the next worksheet in the design. HFORM has not parsed the worksheet yet, but the filename and worksheet number are set. The function is called once for every file in the design.</p>   |
| <pre>int<br/>PreviousNode();</pre>  | <p><i>net-oriented<br/>data<br/>structure<br/>function</i></p> | <p>Makes the previous node current and loads the associated standard symbols. This function returns 1 on success or 0 on start of list. Used with NextNode(), this function allows bi-directional movement through net-oriented data structures. Use this function only when creating format files for hierarchical netlists.</p> |
| <pre>int print<br/>( string_constant );</pre> <pre>int print<br/>( standard_symbol );</pre> <pre>int print<br/>( user_symbol );</pre> <pre>int print( variable );</pre> | <p><i>C-language<br/>functions</i></p>                         | <p>Writes the contents of <b>string_constant</b>, <b>standard_symbol</b>, <b>user_symbol</b>, or <b>variable</b> to the screen. The function returns 0.</p>   |
| <pre>ProcessFieldStrings<br/>();</pre>  | <p><i>required<br/>function for<br/>IFORM</i></p>              | <p>IFORM calls this function.</p>   |
| <pre>int putch( variable )</pre>  | <p><i>C-language<br/>function</i></p>                          | <p>Writes <b>variable</b> to the screen. This function returns the value of <b>variable</b>.</p>  |
| <pre>int puts<br/>( string_constant );</pre> <pre>int puts<br/>( user_symbol);</pre> <pre>int puts<br/>( standard_symbol )</pre>  | <p><i>C-language<br/>functions</i></p>                         | <p>Prints a string or symbol and a newline to the screen. As listed at the beginning of this appendix, arrays are not supported, so the argument is either <b>string_constant</b>, <b>user_symbol</b>, or <b>standard_symbol</b>. This function returns 0.</p>  |



For example:

```
SetAccessType ("LIBRARY");
```

For information about the symbols listed in the table, see the section *Symbol reference*.

**SetCharSet**  
( **string\_constant** );

*general  
function*

Sets the valid character set to be the input string. Using **SymbolInCharSet()**, you can check symbols against the list of valid characters.

**SetFirst**  
( **part\_symbol** );

*part-  
oriented  
netlist  
function*

Makes the first entry in the table indicated by **part\_symbol** current. For example:

```
SetFirst (SIGNALS);
```

**int SetIndexByRef**  
( **user\_symbol** );

*part-  
oriented  
netlist  
function*

Accesses the PARTS table, making the part with the reference specified by **user\_symbol** current. This function returns 1 on success or 0 otherwise.

**int SetNext**  
( **part\_symbol** );

*part-  
oriented  
netlist  
function*

Makes the next index in the table indicated by **part\_symbol** current. This function returns 1 on success or 0 otherwise. This function appears in loop constructs. For example:

```
SetNext (ALL);
```

**SetNumberWidth**  
( **integer\_constant** );

*general  
functions*

**SetNumberWidth**  
( **variable** );

Sets the width of fields containing output number to the value specified by **integer\_constant** or **variable**. Numbers are padded with zeros on the left up to this width when IFORM or HFORM write them to a file or to the screen. Except for the symbol **LocalSignal**, this function has no effect on how numbers are stored. Values of zero or one result in no padding. The default value is one. Wider numbers are not truncated.

|   |  |  |
|---|--|--|
| <pre>int SetPartIndex<br/>( integer_constant<br/>  );</pre>           | <i>part data<br/>structure<br/>functions</i>       | Makes the part specified by <b>integer_constant</b> or <b>variable</b> current and loads the associated standard symbols. This function returns 1 on success or 0 if the index is out of range. Use this function only when creating format files for hierarchical netlists.   |
| <pre>int SetPartIndex<br/>( variable );</pre>                         |  |  |
| <pre>SetPinMap<br/>( integer_constant,<br/>  string_constant );</pre> | <i>general<br/>functions</i>                       | Sets the index for the input pin map specified by <b>integer_constant</b> or <b>variable</b> to the input <b>string_constant</b> . This function accesses a pin map that allows strings to be associated with integer values. You can set up to 16 pin maps.   |
| <pre>SetPinMap<br/>( variable,<br/>  string_constant );</pre>         |  | You use these functions with <b>WriteMap()</b> .   |
| <pre>int SetPrevious<br/>( part_symbol );</pre>                       | <i>part-<br/>oriented<br/>netlist<br/>function</i> | Makes the previous index in the table indicated by <b>part_symbol</b> current. This function returns 1 on success or 0 otherwise. Loop constructs may include this function. For example:<br><br><pre>SetPrevious (PARTS) ;</pre>  |
| <pre>int SetSignal();</pre>   | <i>part data<br/>structure<br/>function</i>        | Finds the matching pin in the net data structure and sets the <b>SignalNameString</b> , <b>SignalType</b> , and <b>TypeCode</b> for the net associated with the pin. This function returns 1 if the pin exists or 0 if the pin is unconnected. You use this function to synchronize the part and net data structures. Use this function only when creating format files for hierarchical netlists. |
| <pre>SetSymbol<br/>( user_symbol,<br/>  string_constant );</pre>      | <i>general<br/>function</i>                        | Assigns the contents of <b>string_constant</b> to <b>user_symbol</b> .   |

|  |  |   |
|--|--|---|
| <pre>int SetToIndex   ( part_symbol,     variable );</pre>                       | <p><i>part-oriented netlist function</i></p> | <p>Sets the index of the table specified by <b>part_symbol</b> to the input variable. Returns 1 on success or 0 otherwise. For example:</p> <pre>SetToIndex (NETS, 5);</pre>  |
| <pre>SetTraversal ( traversal_constant   );  SetTraversal ( user_symbol );</pre> | <p><i>traversal functions</i></p>            | <p>Sets the way HFORM traverses a design. A top down traversal is a depth first traversal that starts at the root. A bottom up traversal is a breadth first traversal that starts at the leaf nodes. The input value <b>traversal_constant</b> is either "ROOT" or "LEAF", and <b>user_symbol</b> should evaluate to either ROOT or LEAF. For example:</p> <pre>SetTraversal ("ROOT");</pre>  |
| <pre>SortByNumber();</pre>   | <p><i>instance file function</i></p>         | <p>Sorts only the instance file by reference number. As a side effect, the seek pointer is set to start of file, so if you have made a pass through the instance file using <b>LoadInstance</b>, a <b>SortByNumber()</b> call allows you to make another pass through the file using <b>LoadInstance</b>. Using this function on a part-oriented data structure causes the data structure to become invalid. See <b>CreatePartDatabase()</b>.</p> |
| <pre>int SwitchIsSet ( string_constant );</pre>                                  | <p><i>general function</i></p>               | <p>Checks to see if the switch specified by <b>string_constant</b> is set. This function returns 1 if the switch is set or 0 if not. The first character in the input <b>string_constant</b> is the only relevant character. The character must be an alphabetic character. Include this function during initialization.</p>  |
| <pre>int SymbolInCharSet ( user_symbol );</pre>                                  | <p><i>general function</i></p>               | <p>Checks the contents of the string associated with <b>user_symbol</b> against the current character set. The function returns 1 if all characters in the symbol are in the character set or 0 otherwise. The function <b>SetCharSet()</b> defines the character set.</p>  |



|   |  |  |
|---|--|--|
| <b>int SymbolLength</b><br><b>( symbol );</b>                         | <i>general<br/>function</i>                | Returns the length of the string represented by <b>symbol</b> .  |
| <b>ToUpper</b><br><b>( user_symbol );</b>                             | <i>general<br/>function</i>                | Changes any lowercase alphabetic characters in <b>user_symbol</b> to uppercase.  |
| <b>WriteCrLf</b><br><b>( file_index );</b>                            | <i>general<br/>function</i>                | Writes a newline to the file specified by <b>file_index</b> .  |
| <b>WriteHeader();</b>   | <i>required<br/>function for<br/>IFORM</i> | IFORM calls this function. It can do two things, depending on the functions you include: output a header or build a part database using the function <b>CreatePartDatabase()</b> .   |
| <b>WriteMap</b><br><b>( file_index,</b><br><b>integer_constant );</b> | <i>general<br/>functions</i>               | Writes the pin map string at <b>integer_constant</b> or <b>variable</b> to the file given by <b>file_index</b> . See also the <b>SetPinMap()</b> functions.  |
| <b>WriteMap</b><br><b>( file_index,</b><br><b>variable );</b>         |  |  |
| <b>WriteNet();</b>  | <i>required<br/>function for<br/>IFORM</i> | IFORM calls this function, setting <b>PinIndex</b> , <b>ReferenceString</b> , <b>PinNumberString</b> , <b>PartName</b> , <b>ModuleName</b> , and <b>PinType</b> . Then, depending on the functions you include, this function should either write the current net for net-oriented netlists or add the net to a part-oriented netlist by calling the function <b>RecordNet()</b> . |
| <b>WriteNetEnding();</b>  | <i>required<br/>function for<br/>IFORM</i> | IFORM calls this function when it reaches the end of a net. Then this function outputs whatever you specified to terminate nets.   |

---

|  |  |  |
|--|--|--|
| <code>WriteNetListEnd<br/>( );</code>                                | <i>required<br/>function for<br/>IFORM</i> | IFORM calls this function after reading all the nets. The function should either output whatever you specify to terminate a net-oriented netlist or traverse a part-oriented data structure and output the netlist that was recorded by calls to <code>WriteNet()</code> . |
| <code>WriteStdSymbol<br/>( file_index,<br/>standard_symbol );</code> | <i>general<br/>function</i>                | Writes <code>standard_symbol</code> to the file specified by <code>file_index</code> .   |
| <code>WriteString<br/>( file_index,<br/>string_constant );</code>    | <i>general<br/>function</i>                | Writes the <code>string_constant</code> to the file indicated by <code>file_index</code> .   |
| <code>WriteSymbol<br/>( file_index,<br/>user_symbol );</code>        | <i>general<br/>function</i>                | Writes <code>user_symbol</code> to the file specified by <code>file_index</code> .   |

## **Error and warning messages**

When you run IFORM or HFORM with a netlist format that contains one or more errors, the process stops at the first error and an error message and line number display. When you run IFORM and HFORM under ESP, the file #ESP\_OUT.TXT contains the error messages.

For information about warnings, errors, and the Ignore warnings option, see the entry **ExitType** in the reference portion of this appendix.

The errors messages include:

**Cannot SortByNumber after CreatePartDatabase.** Calling the function **SortByNumber()** scrambles the data in the part-oriented data structure.

**Closing comment, no opening comment.** A closing comment (**\*/**) was found but no opening comment (**/\***) was found.

**Closing quote expected.** A string constant was found but not correctly terminated.

**Equal sign expected.** An assignment was attempted without the equal sign (**=**).

**Function expected.** A function definition or call was expected.

**Index out of range.** The index is out of range. Either a file index or a pin map index is not valid.

**Nested comments.** Two opening comments (**/\***) were found before a closing comment (**\*/**) was found.

**No expression present.** An expression was expected but none was found.

**Not a string.** The value required should be a string constant.

**Not a variable.** An attempt to set or read a value that is not a variable.

**Opening comment, no closing comment.** An opening comment (**/\***) and end of file were found before a closing comment (**\*/**) was encountered.

**Parameter error.** A general error for internal functions when a parameter type did not match.

**Parentheses expected.** A parentheses—either “(” or “)”—was expected but not found.

**RETURN without call.** A return statement was found before a function call was made.

**Semicolon expected.** The start of another statement was found before a terminating semicolon ( ; ) was found.

**Symbol not found.** The intended symbol was not found in either the standard symbol table or the user symbol table.

**Symbol table overflow.** An attempt to add too many user defined symbols. Use fewer symbols.

**Syntax error.** General syntax error.

**Too many local variables.** The local variable table has overflowed. Try using fewer variables or try to make some of them global.

**Too many nested function calls.** The internal function call stack was exceeded. Reduce the call nesting depth.

**Type specifier expected.** A variable declaration needs to have a type (int or char) supplied.

**Unbalanced braces.** Found a statement requiring a matched set of curly braces ( { and } ) before encountering a closing curly brace ( } ) such as in a function definition.

**Unbalanced parentheses.** An end of a statement was found before the final closing parentheses ( “)” ) was found.

**While expected.** Do-while statement ended the block, but a while was not found.





## *Plotter information*

This appendix contains additional information you may need to setup, configure, and use your plotter with **Schematic Design Tools**. The sections in this appendix discuss:

- ❖ Plotter cable wiring
- ❖ Plotter problems
- ❖ Plotter hints
- ❖ Plotting to a printer
- ❖ HP plotters
- ❖ HI plotters
- ❖ Calcomp plotters
- ❖ Plotter driver considerations
- ❖ Postscript plotter drivers

## Plotter cable wiring

The Plot Schematic tool uses DOS BIOS calls to communicate with the serial port. It does not talk to the hardware directly. This is to ensure compatibility with all PC's and compatibles.

For this reason, additional wires other than TXD and RXD must be connected to implement hardware handshake.

Figure D-1 is a wiring diagram showing the connections necessary to connect a 25-pin connector to a plotter. Figure D-2 is a wiring diagram showing the connections necessary to connect a 9-pin connector to a plotter. Figure D-3 is a wiring diagram showing the connections necessary for a 25-pin connector to an IOLine plotter.

Since this cable connects the TXD and RXD lines, it also works with software that communicates to the hardware directly.

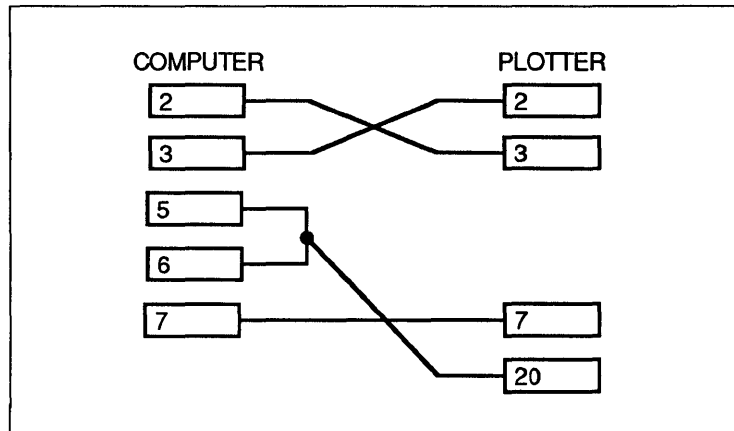

Figure D-1. 25-pin cable wiring diagram.

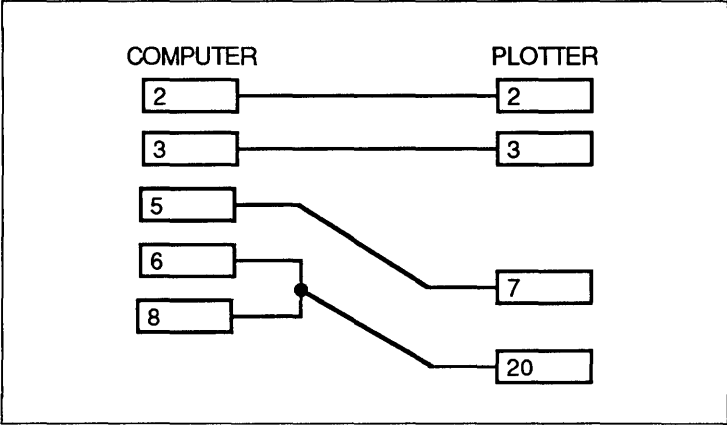

Figure D-2. 9-pin cable wiring diagram.

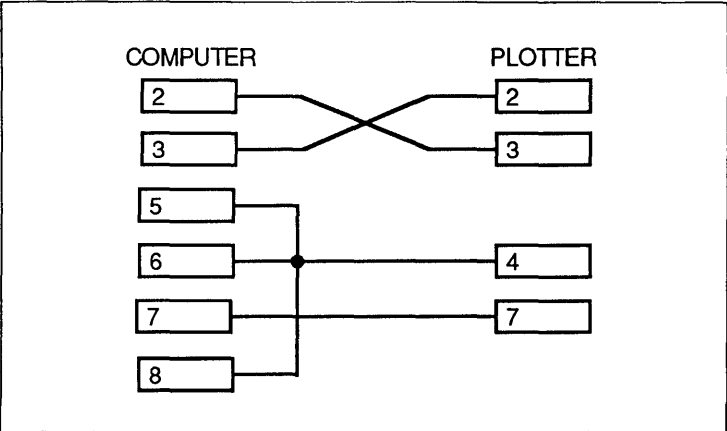

Figure D-3. 25-pin cable to IOline plotter.



## **Plotter problems**

Most plotter problems are caused by incorrectly wired plotter cables. If you have difficulty with your plotter, check the following items before proceeding or calling OrCAD:

1. Wire the cable as shown in Figures D-1, D-2, and D-3. If your plotter works with another software package, and does not work with OrCAD, the first item to check is the wiring of your cable. Chances are the other CAD packages only require the TXD and RXD signal lines. OrCAD requires additional connections.

**The cable must be wired as recommended.**

2. Check for an open in the cable by performing a continuity check.
3. Read your plotter manual to be sure you understand how the plotter operates. Know how it is programmed for baud rate, parity, word length, and find out what these settings are.
4. Ensure that the plotter baud rate, parity, and word length settings correspond to the plotter configuration information.
5. Select the **View Reference Material** button on the **Schematic Design Tools** screen to see other reference material about plotting.
6. Use DOS to send a plot file to the plotter. This is useful for isolating whether the problem is in the serial port hardware or the plotter hardware. To do this, first send the worksheet to a plot file as outlined below:

Use the **Plot Schematic** tool to plot to a file.

Then, use the DOS MODE command to configure the serial channel as follows:

```
MODE COM1:2400,N,8,1,P
```

This assumes that you are using serial channel 1 (COM1) and have your plotter set for 2400 baud, no parity, 8 data bits, and 1 stop bit. For more information on the MODE command, see your DOS user's guide for Asynchronous Communications.

After the serial channel has been configured, send the plot file to the plotter using the DOS COPY command as follows:

```
COPY whatfile COM1:
```

Where *whatfile* is the name of the plot file.

If the plotter works, this indicates the problem may be in the plotter cable (incorrectly wired), or the hardware handshaking is incorrectly set (check the **Printer/Plotter Output Options** section of the **Configure Schematic Design Tools** screen).

If the plotter does not work, this indicates that there is a hardware problem. Check the following: serial card, incorrect serial channel configuration, plotter hardware, or a cable problem.

7. If you're using an I/Oline plotter, be sure you have PROM version 114 or greater.

## Plotting to a printer

When plotting to a printer, make the pen width for buses small enough to make the lines thin. This will make the print neater and more readable. For example, if you have a printer with a resolution of 180 dots per inch (dpi) you would set the pen width to be:

$$\frac{\left(\frac{1}{180}\right)}{2} = 0.00277 \text{ inches}$$

for the best results. The same value is also used for the part body pen width. This pen width value is used during FILL commands in the vector stream of the part definition.

## General plotter tips

When making a plot, use the proper pens and paper designed for the plotter. Plotter paper has a “memory” to it. If it hangs on the plotter bed for a period of time, it will stretch. This effects the registration of the plot. Plotter paper is also temperature sensitive. Be sure that the paper is at room temperature before plotting. The longer the drawing takes to plot, the more care must be exercised with the paper.

The configuration of the plotter includes the ability to change the velocity of the pens. When the pen cannot draw at the speed the plotter is capable of moving, reduce the velocity. You will need to consult your plotter manual for the range to set the velocity. The velocity can be set only in whole number values.

When you make a plot with different pens, the plotter has a registration inaccuracy that must be considered. If you wish to have the highest quality plot, always use only one pen.

When you are directed by the program to change paper or pens, always wait until the plotter has finished the present plotting activity. Before sending a plot directly to the plotter, be sure that the plotter is on line, the pen(s) are properly set up, and the paper size is correct. When you have a pen that must be manually changed, the **Plot Schematic** program will pause and inform you of the objects to be plotted with the new pen.

Make sure that the template Horizontal and Vertical dimensions are correct for your plotter. Some plotters have a larger margin requirement and, therefore, less usable plotting area. Check your plotters user’s manual to get the actual plot area dimensions and change the values in the **Template Table** area of the **Configure Schematic Design Tools** screen accordingly. You have this problem if the top or right edge of your plot is clipped. In addition, you may use more plot area if your plotter has a usable plot area greater than that set in the **Template Table** section of the **Configure Schematic Design Tools** screen. If this is true, change the **Template Table**.

## HP plotters

The HP plotter family has a facility to set the corner points of the plot and automatically scale the plot to be within these points. These points are called P1 and P2. **Plot Schematic** ignores the preset P1 and P2 values and draws in 0.001 inch resolution.

**Plot Schematic** assumes the origin of the plot is the lower left corner of the page (when the finished plot is viewed). Rotation and paper size must be set before you run a plot.

If the plotter's origin (0,0) is not the lower left corner, it may be moved via the **Template Table** section of the **Configure Schematic Design Tools** screen. To move the origin, configure the **Plot X Offset** and **Plot Y Offset** (value 32.76 inches to +32.76 inches) in the **Template Table**. Note that this origin offset can be used on any plotter to adjust where the plot is made on the page.

For large HP plotters (HP 7580, 7585, 7586), the origin is the center of the page and the template offset values must be set. For these HP plotters, the offset values are *negative*. The offset values are added to the location values and then sent to the plotter.

For example, suppose you set the **Plot X Offset** to -10 and the **Plot Y Offset** to -5. If your plot contains the logical point X=1 and Y=2, that point is actually sent to the plotter as X=-9 and Y=-3 ( $-9 = 1 + -10$ ;  $-3 = 2 + -5$ ).

---

## HI plotters

The HI 40 Series defaults to 2400 baud, and the 50 Series defaults to 9600. Always check to make sure that the plotter baud rate, and data bit settings correspond to the **Printer/Plotter Output Options** section of the **Configure Schematic Design Tools** screen.

Be sure that the plotter is on line before beginning a plot. The HI plotters do not have a means to set the velocity to the power-up default. If you change any of the velocity settings of the pens in the configuration, you will need to change them all. The velocity ranges can be found in the plotter operation manual for your specific plotter.

On HI plotters that print on D and E size paper, you may need to change the horizontal dimension in the **Template Table** section of the **Configure Schematic Design Tools** screen. For example, you may need to change the D-size horizontal dimension from 32.2 inches to 32.0 inches.

---

## Calcomp plotters

This section lists supported Calcomp plotters and provides setup information for the Calcomp 1043 plotter. You must have one of the listed controllers (supplied by Calcomp) for the plotter to work. See your Calcomp plotter documentation for configuration information.

OrCAD has followed Calcomp's recommended procedure for connecting a Calcomp plotter to the IBM PC. Thus, *any cabling changes that Calcomp recommends should be followed instead of the cabling information in this manual.*

**Tables of supported  
Calcomp plotters**

This section contains two tables listing intelligent and non-intelligent Calcomp plotters supported by **Schematic Design Tools**. The following characters are used in the tables to provide support information about the plotters:

- 1 Use CALCOMP1.DRV for **Schematic Design Tools**.
- 2 Use CALCOMP2.DRV for **Schematic Design Tools**.
- . Configuration not supported by Calcomp Company.
- X Plotter and controller configuration supported by Calcomp Company. There is no driver for **Schematic Design Tools**.
  - a The 906 controller and 960 format lack of built-in commands to draw circles, arcs, and dashed lines.
  - b The extended 960 format is not supported because of a different command code structure.
  - c The remaining unsupported configurations are due to differences in plotter step size. The two CALCOMP drivers use a step size of 2032. **Schematic Design Tools** does not support this step size.

| Supported Plotters     | Controllers |     |           |         | No Controller |            |                |
|------------------------|-------------|-----|-----------|---------|---------------|------------|----------------|
|                        | 906         | 907 | 907 Rev G | 951/953 | PCI           | 960 Format | Ext 960 Format |
| <i>Non-Intelligent</i> |             |     |           |         |               |            |                |
| 1012                   | Xa          | -   | -         | -       | -             | -          | -              |
| 1037                   | Xa          | Xc  | Xc        | -       | -             | -          | -              |
| 1038                   | Xa          | Xc  | -         | -       | -             | -          | -              |
| 1039                   | Xa          | Xc  | -         | -       | -             | -          | -              |
| 1051                   | Xa          | Xc  | Xc        | Xc      | -             | -          | -              |
| 1055                   | Xa          | 2   | 2         | 2       | -             | Xa         | -              |
| 1060                   | Xa          | 2   | 2         | 2       | -             | Xa         | -              |
| 1065                   | Xa          | 2   | 2         | 2       | -             | Xa         | -              |
| 960                    | Xa          | 2   | 2         | 2       | -             | Xa         | -              |
| 970                    | Xa          | 2   | 2         | 2       | -             | Xa         | -              |
| 5200                   | -           | -   | -         | Xc      | -             | Xa         | -              |
| 5500                   | -           | -   | -         | Xc      | -             | -          | -              |
| 5732                   | -           | -   | -         | Xc      | -             | -          | -              |
| 5734                   | -           | -   | -         | Xc      | -             | -          | -              |
| 5742                   | -           | -   | -         | Xc      | -             | -          | -              |
| 5744                   | -           | -   | -         | Xc      | -             | -          | -              |
| 5754                   | -           | -   | -         | Xc      | -             | -          | -              |
| <i>Intelligent</i>     |             |     |           |         |               |            |                |
| 945                    | -           | -   | 1         | 1       | 1             | -          | Xb             |
| 945A                   | -           | -   | 1         | 1       | 1             | -          | Xb             |
| 965                    | -           | -   | 1         | 1       | 1             | -          | Xb             |
| 965A                   | -           | -   | 1         | 1       | 1             | -          | Xb             |
| 1042                   | -           | -   | -         | 1       | 1             | -          | Xb             |
| 1042GT                 | -           | -   | -         | 1       | 1             | -          | Xb             |
| 1043                   | -           | -   | -         | 1       | 1             | -          | Xb             |
| 1043GT                 | -           | -   | -         | 1       | 1             | -          | Xb             |
| 1044                   | -           | -   | -         | 1       | 1             | -          | Xb             |
| 1044GT                 | -           | -   | -         | 1       | 1             | -          | Xb             |
| 1073                   | -           | -   | 1         | 1       | 1             | -          | Xb             |
| 1075                   | -           | -   | 1         | 1       | 1             | -          | Xb             |
| 1076                   | -           | -   | 1         | 1       | 1             | -          | Xb             |
| 1077                   | -           | -   | 1         | 1       | 1             | -          | Xb             |

Table D-1. Supported Calcomp plotters—see the next page for the legend for this table.



| NO. | Selection                      | AUTOCAD          | OrCAD            |
|-----|--------------------------------|------------------|------------------|
|     | PARITY BITS                    | 2 - EVEN<br>7    | 0 - NONE<br>8    |
| 1   | STOP BITS<br>CLOCK             | 1<br>0 - INT     | 1<br>0 - INT     |
| 2   | INTERFACE                      | 0 - SERIAL       | 0 - SERIAL       |
| 3   | HOST BAUD RATE<br>MODE         | 9600<br>PCI      | 9600<br>PCI      |
| 4   | TERM MUTING<br>CHECKSUM ENABLE | NO<br>YES        | NO<br>NO         |
| 5   | ISOCRONOUS<br>EOM              | NO<br>13         | NO<br>03         |
| 6   | DIRECT CONTROL<br>XON/XOFF     | NO<br>NO         | YES<br>NO        |
| 7   | TERM BAUD RATE<br>DUPLEX       | 9600<br>0 - FULL | 9600<br>0 - FULL |
| 8   | SYNC CODES<br>SYNC CODE VALUE  | 2<br>022         | 1<br>002         |

Table D-3. SETUP-7 communications.

|                     | AUTOCAD | OrCAD |
|---------------------|---------|-------|
| ENABLE OPTIMIZATION | YES     | NO    |

Table D-4. Plot management.

| 0 --> 1 | AUTOCAD | OrCAD |
|---------|---------|-------|
| POS - 1 | 0       | 0     |
| POS - 2 | 0       | 1     |
| POS - 3 | 0       | 0     |
| POS - 4 | 0       | 1     |
| POS - 5 | 1       | 0     |
| POS - 6 | 0       | 0     |
| POS - 7 | 0       | 0     |
| POS - 8 | 0       | 0     |

Table D-5. Switch settings.

---

## Notes on plotter and printer drivers

This section contains notes on the following plotter and printer drivers:

- ❖ HP.DRV
- ❖ HPLASERx.DRV
- ❖ DXF.DRV
- ❖ Postscript drivers

### HP.DRV

This driver may report a divide error on D or E-size sheet if you did not set the **Plot X Offset** and **Plot Y Offset** on the **Configure Schematic Design Tools** screen. This is because the values that the HP plotter uses are plotter units, not inches. A plotter unit is 0.00098 inch. The plotter units must be a 16-bit integer value (–32768 to +32767). **Plot Schematic** computes all dimensions with much greater range.

The plotter driver is passed word values (0.000 to +65.535) and these are converted into plotter units after adding the offset. For example, the D-size horizontal dimension of 32.2 inches with an offset of 0.000 inches would be converted by the driver to:

$$\frac{32.200}{0.00098} = 32857 \text{ units}$$

This value exceeds the integer limit. To be able to plot D and E-size drawings, the full integer range must be used. Therefore, the large paper plotters have the origin (0,0) in the center of the paper. The drawing coordinate system is adjusted by the **Plot X Offset** and **Plot Y Offset** on the **Configure Schematic Design Tools** screen to move the origin to the correct position. Typically, the offset is  $\frac{1}{2}$  of the paper dimension.

Another consequence of not setting the **Plot X Offset** and **Plot Y Offset** on the **Configure Schematic Design Tools** screen is that plotters having the origin in the center will draw only on the upper right quadrant of the paper. If your drawing appears this way, set the **Plot X Offset** and **Plot Y Offset** on the **Configure Schematic Design Tools** screen to move the origin to the lower left corner of the paper.

**HPLASERx.DRV** Some laser printers have a graphics printing limit. The **Schematic Design Tools** drivers place page breaks after a given number of graphics lines. To change the number of graphics lines between page breaks, change the word value in the driver at the offset specified below. The driver values were chosen to be a 10 inch graphics printing area.

| <i>Driver</i> | <i>Offset</i> | <i>Old value</i> |
|---------------|---------------|------------------|
| HPLASER1.DRV  | 401h          | 02EEh (750)      |
| HPLASER2.DRV  | 41Ch          | 03EBh (1000)     |
| HPLASER3.DRV  | 44Eh          | 05DCh (1500)     |
| HPLASER4.DRV  | 4E4h          | 0BB8h (3000)     |

**DXF.DRV** This driver puts a drawing into a format usable by AutoCAD and some desktop publishing programs. Use **Plot Schematic** to plot to a file with this driver. In AutoCAD, use the *dxfin* command to read the file written by **Plot Schematic**. You will have to rename the file to have a .DXF extension. If you want colors (layers), enter the pen number in the **Pen** entry box in the **Color and Pen Plotter Table** section of the **Configure Schematic Design Tools** screen to put the different objects onto different layers.

△ *NOTE: Dashed lines will always be layer 0 due to line definition restrictions.*

**PostScript** To create a PostScript file that can be printed by any PostScript compatible device on either paper or film, use the PSCRIPT.DRV plotter driver. To create ledger-size PostScript images, use the PSCRIPT2.DRV. For more information about PostScript, see the *PostScript Language Reference manual* and the *PostScript Language Tutorial and Cookbook*, both published by Addison-Wesley in 1985.

*Encapsulated PostScript* To produce Encapsulated PostScript (EPS) files to import into other application programs (such as word processing and page layout programs) as illustrations, use one of these four plotter drivers:

EPS1.DRV Letter size, landscape

EPS2.DRV Letter size, portrait

EPS3.DRV Legal size, landscape

EPS4.DRV Legal size, portrait

Files produced by these drivers can be used by any application that accepts EPS V2.0.

Like other "standards," some applications interpret EPS a little differently than others. Usually the problem can be corrected with a minor adjustment to the plot file. If you have trouble importing EPS into an application, contact technical support at the developer of your application to determine its exact requirements for EPS. For more information about EPS, contact Adobe Systems Incorporated, 1585 Charleston Road, Mountain View, CA 94039.

*Other PostScript* To produce a PostScript file for the special PostScript "environment" within the Macintosh version of Microsoft Word, use the PWORD.DRV plotter driver. PWORD files can be placed into Word documents or can be incorporated by reference using Word's include and Print Merge features. PWORD files start with Word's special *.para.* operator. For more information about Word's PostScript environment, see Microsoft's *Reference to Microsoft Word* manual.

## A

**analog** ■ Circuitry where both voltage and frequency output vary continuously as a function of the input.

**annotation** ■ Assigning reference designators to components in a schematic.

**ASCII** ■ An acronym for *American Standard Code for Information Interchange*; a seven-bit code used to represent letters of the alphabet, the ten decimal digits, and other instructions used to edit text on a computer, such as Backspace, Carriage Return, Line Feed, etc.

---

## B

**bitmap** ■ An image made up of dots (bits).

**bulletin board system** ■ A computer dedicated to maintaining messages and software and making them available over telephone lines. People *upload* (contribute) and *download* (gather) messages by calling the bulletin board from their own computers. Abbreviated BBS.

**button** ■ A pushbutton-like image that you click to initiate an action.

**byte** ■ A piece of computer data composed of 8 contiguous bits that are grouped together as a single unit.

---

## C

**CAE** ■ An acronym for *computer aided engineering*.

**check box** ■ A small square button: . Check boxes are used in lists of options when more than one option can be active at a time.

**child** ■ A worksheet containing circuitry referred to by a sheet, sheet part, or sheetpath part. The child may contain module ports that connect signals from this worksheet to signals on the parent. A child can also be a parent, if it contains a child.

**complex hierarchy** ■ A design in which two or more sheet symbols reference a single worksheet. Compare with *simple hierarchy*.

**configuration** ■ The information a program uses to operate. The configuration can be tailored to your needs.

**connectivity database** ■ The *connectivity database* consists of the incremental connectivity database (created by INET) and the linked connectivity database (created by ILINK). It describes the connectivity of a design, and is used to transfer a design to **Digital Simulation Tools** or **PC Board Layout Tools**. See *incremental connectivity database* and *linked connectivity database*.

**cursor** ■ A square marker inside a text field showing where characters typed on the keyboard will appear: ■  
See *pointer*.

---

## D

**default** ■ A value or setting provided by the software that is assumed to be correct in most cases and is used if no other value is entered.

**design cycle** ■ The process of conceiving, developing, testing, and producing a circuit.

**digital** ■ Circuitry where data in the form of digits are produced by binary on and off or positive and negative electronic signals.

**dpi** ■ An abbreviation for *dots per inch*.

---

## E

**EDA** ■ An acronym for *electronic design automation*.

**editor** ■ A tool used to create or modify a design file.

**EMS** ■ An acronym for Extended Memory Standard.

**entry box** ■ A box indicating that something (text or numbers) should be entered using the keyboard:

---

## F

**flat design** ■ A schematic structure in which output lines of one sheet connect laterally to input lines of another sheet through graphical objects called *module ports*. Flat designs are practical for small designs of three or fewer sheets. See *module port*, *schematic*, *hierarchical structure*.

---

## H

**hierarchical design** ■ A schematic structure in which sheets are interconnected in a tree-like pattern vertically and laterally. At least one sheet, the root sheet, contains symbols representing other sheets, called subsheets.

---

## I

**incremental connectivity database** ■ INET produces the *incremental connectivity database*. It consists of an incremental connectivity database file (.INF) for each sheet in the design and an .INX file. The .INF file is a description of connectivity on each sheet. The .INX file lists each sheet referenced in the design. The *incremental connectivity database* is used by ILINK to create an incremental netlist. See *connectivity database* and *incremental netlisting*.

**incremental netlisting** ■ A method of creating a netlist in which only changed worksheets are processed each time **Create Netlist** or **Create Hierarchical Netlist** runs.

**initial macro** ■ A macro that runs automatically when you run **Draft** or **Edit Library**. For the initial macro to work, you must configure **Schematic Design Tools** to load a macro file containing the desired macro definition.

**intermediate netlist structure** ■ ILINK produces the *incremental netlist structure*. This consists of the .INS (instance) file, the .RES (resolved) file, and the .PIP file (contains pipe link commands). These files are used by IFORM to create a netlist in one of over 30 formats.

---

## K

**K** ■ A unit of measurement. 1K byte is equal to 1024 bytes. The “K” is taken from the metric system, where it stands for “kilo,” or 1000. 1024 is  $2^{10}$  and is close to 1000.

**key field** ■ To tell Draft and other tools which fields you want to combine and compare, *key fields* are used. A key field lists the part fields to combine and compare. Key fields are defined on the Configure Schematic Design Tools screen.

---

## L

**library** ■ A collection of standard, often-used part symbols stored as templates to speed up design.

**librarian** ■ A tool used to manage or create library parts.

**linked connectivity database** ■ ILINK can optionally be configured to create the *linked connectivity database*. This ASCII file has an extension of .LNF and is used to transfer to PC Board Layout Tools.

**local configuration** ■ Configuration settings for a particular button. Roughly synonymous with *command line switches*. The same tool can have

different configuration in different places in the same design. For example, Netlist is configured differently under the To Layout button and under the To Simulate button.

---

## M

**MB** ■ An abbreviation for *megabyte*. See *megabyte*.

**macro** ■ Series of commands you can execute automatically at the touch of a single key or key combination. Macros dramatically reduce the number of keystrokes required to perform complex or repetitive actions.

**megabyte** ■ Slightly more than one million bytes; 10 megabytes equals 10 million bytes. A megabyte is equal to  $2^{20}$  bytes (1,048,576). “Mega” is taken from the metric system, where it is a prefix meaning one million.

**module port** ■ Graphical objects that conduct signals between schematic worksheets. See *flat file*.

---

## N

**net** ■ Just as signals are conducted between schematic worksheets through module ports, they are conducted into and out of sheet symbols through graphical objects called *nets*.

**netlist** ■ An ASCII file that lists the interconnections of a schematic diagram by the names of the signals, modules, and pins connected together on a PCB. The nodes in a circuit. See *incremental netlisting*.



---

## P

**PCB** ■ An acronym for *printed circuit board*.

**package** ■ A physical component. A package may contain one or more sub-parts. For example, a 2N3905 transistor, a fuse, and a 74LS00 are packages.

**pan** ■ To change the portion of the worksheet being viewed by dragging the pointer from one location on the worksheet to another location. As you drag the pointer, the worksheet *pans* across the screen.

**parent** ■ A worksheet that contains hierarchical references to other worksheets. These references are either sheets, sheet parts, or sheetpath parts, which are, from the viewpoint of the parent worksheet, children.

**part** ■ A schematic symbol that represents an object. The object can be either a package or another worksheet. OrCAD schematics can have four kinds of parts: packages, sheets, sheet parts, and sheetpath parts.

**part field** ■ A slot for holding text or data to be associated with a part. Each part has two part fields reserved for part value and part reference. It has eight other part fields that can be used to store other useful information. See *key fields*.

**pixel** ■ Any of the little dots of light that make up the picture on a computer or television screen. The name is short for *picture element*. There more pixels there are in an area—the smaller and closer together they are—the higher the *resolution*. Sometimes pixels are just called dots.

**pointer** ■ An arrow on the screen that moves as you move the mouse:  See *cursor*.

**processor** • A tool that subjects a design file to a specific process.

**programmable logic device** ■ A type of integrated circuit that contains fuses that can be blown, eliminating certain logical operations in the device and leaving others intact, giving the device one of many possible logical architectures or logical configurations.

**prompt** ■ A query from a program asking you to enter specific information.

---

## Q

**quiet mode** ■ An option on the local configuration screen for many tools. When quiet mode is selected, tracking information does not echo on the screen. Only execution messages and error messages (if any) display. If quiet mode is turned off (not selected), the tool displays intermediate tracking information in the monitor box at the bottom of the screen. For most applications you do not need to turn quiet mode on.

---

**R**

**radio button** ■ A small round button: ○. Radio buttons are used in lists of mutually exclusive options: only one button can be active at a time.

**raster** ■ An array of dots.

**reporter** ■ A tool that creates a report, but does not modify design data.

**root directory** ■ The main directory on your computer; the directory that the computer boots from.

**root sheet** ■ The worksheet at the top of a flat or hierarchical design. A design has only one root worksheet. A root worksheet may also be a parent in hierarchical designs.

---

**S**

**schematic** ■ A graphical representation of a circuit using a standard set of electronics symbols. See *flat design*, *hierarchical design*, and *root sheet*.

**scroll buttons** ■ Buttons used to move a directory in its window so that a different part is visible. The four scroll buttons are:

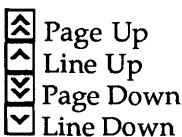

**sheet** ■ A schematic symbol referring to a worksheet located in the design area and containing circuitry. The connection points on sheets are called sheet nets. See *nets* and *sheet net*.

**sheet net** ■ The point at which a signal from a parent connects to a module port on a child. Sheets, sheetpath parts, and sheet parts each have sheet nets.

**sheet part** ■ A library part modified from a sheetpath part to represent a unique instance of a library circuit. Sheet parts refer to worksheets located in the design area as opposed to worksheets located in the library directory. The symbol resembles package symbols, but the pins are called sheet nets.

**sheetpath part** ■ A part representing a library circuit. The worksheet referenced by the sheetpath part is stored in the library directory. The pins on a sheetpath part are called sheet nets to distinguish them from pins on a package.

**simple hierarchy** ■ A one-to-one correspondence between sheet symbols and the schematic diagrams they reference. Each sheet symbol represents a unique subsheet. See *hierarchical design*.

**sub-part** ■ A gate or some other subdivision of a package. Each sub-part in a package has a unique reference designator comprised of a prefix common to all the parts in the package and a letter unique to each part. For example, an instance of a 74LS00 in a design with a package reference designator of U15 would have reference designators for each of the four sub-parts as U15A, U15B, U15C, and U15D.

**syntax** ■ The formal structure of a language. Syntax includes the rules for making statements in the language, but excludes the meanings of the statements.

---

## T

**tag** ■ A marked or saved location on a schematic or layout. You can use the **JUMP** command to go to a tag.

**text export** ■ The process of copying text from a schematic worksheet to an ASCII file.

**text import** ■ The process of copying text from an ASCII file to a schematic worksheet.

**TTL** ■ An acronym for *transistor transistor logic*.

**tool** ■ A tool is a computer program you can use to do some useful task. Tools are grouped into five categories: editors, processors, reporters, librarians, transfers.

**tool set** ■ A collection of tools designed to perform a suite of electronic design automation tasks. OrCAD tool sets include: **Schematic Design Tools**, **Programmable Logic Design Tools**, **Digital Simulation Tools**, and **PC Board Layout Tools**.

**transfer** ■ A tool that transfers design information from one tool set to another tool set. Also runs whatever processes are necessary to go from one tool set to another.

---

## U

**upload** ■ The process of sending a file to another computer.

**user button** ■ A button that you can set up to perform whatever combination of functions you find useful (such as run programs or batch files). User button definitions are saved with the design files, so you can create design-specific buttons and not worry about overwriting user button definitions for other designs.

---

## V

**vector** ■ A series of points with a specific function defined. For example, a vector for a line specifies a line function, a beginning point, and an ending point.

---

## W

**wildcard** ■ A symbol that means any character or any sequence of characters (just as a wild card in poker can stand for any card). Wildcards are useful in searches.

**worksheet** ■ Draft calls the sheets of drafting paper on which the schematics are drawn *worksheets*. Worksheets appear on the computer screen as a rectangular area in which you can place parts and draw wires.

---

## Z

**zoom** ■ The ability to change the view on the screen by making the objects appear larger or smaller.

## Special Characters

"Enter" and "Type" *xxvii*  
 .i.bitmap 673  
 <Ctrl><Break> 109  
 <End> 5  
 <Enter> *xxvi, xxvii*  
 <Esc> *xxvi*  
 <Home> 5  
 <Macrobreak> 109  
 <Page Down> 5  
 <Page Up> 5  
 <Shift><Tab> *xxvii*  
 <Tab> *xxvii*  
 | LINK 197 (*see also: pipe link*)

## A

Active library 16  
     Draft 72  
 AGAIN command  
     Draft 61  
     Edit Library 269  
 Algorex netlist format 506  
     ALGOREX.CF 506  
 AlteraADF netlist format 508  
     ALTERAAD.CF 508  
     including equations in the netlist 510  
 analog 673  
 ANNOTATE 433 (*see also Annotate Schematic*)  
     To Digital Simulation 452  
     To Layout 469  
     To PLD 437  
 Annotate Schematic *xxv, 179-184*  
     Before and after 181  
     Complex hierarchy 183  
     Digital Simulation Tools 183  
     Execution 179  
     Incremental annotation 184  
     Key Fields 40-42, 180

Annotate Schematic (continued)  
     Local Configuration 182  
         File Options 182  
         Processing Options 183  
     Part designation 38  
     Reference designators 40, 179  
     Unconditional annotation 184  
 annotation 673  
 ANSI  
     Grid references 22  
 ANSI title block 21  
 Applicon LEAP netlist format  
     APPLLEAP.CF 513  
 AppliconBRAVO netlist format  
     APPLBRAV.CF. 512  
 Archive Parts in Schematic  
     COMPOSER 252  
         Configuration 256  
         File Options 256  
         Processing Options 258  
     Execution 251  
     LIBARCH 252  
         Configuration 253  
         File Options 253  
         Processing Options 255  
     Local Configuration 252  
     Sheetpath parts 255  
     String files 254, 255  
 Arrow buttons 5  
 ASCII 673  
 Auto panning  
     Draft 147  
 AutoCAD 671  
 Available Display Drivers  
     Configure Schematic Design Tools 8  
 Available Plotter Drivers  
     Configure Schematic Design Tools 10  
 Available Printer Drivers  
     Configure Schematic Design Tools 9

## B

Back Annotate 179, 185-187

Execution 185

Local Configuration 186

File Options 186

Processing Options 187

Was/Is file 185, 186

BACKANNO (see also Back Annotate)

Backing up a worksheet

Draft 147

BAK file 189

Baud rate 11

Benefits 157

Bill of Materials *xxv*

Adding information to 421

Include file format 422

Merging an include file with 421

Bios 11

Bit map images

Edit Library 288

bit-mapped parts 273

bitmap 260

Bitmap definition 327

maximum number of bits 342

BLOCK command

Draft 62-70

ASCII Import 69

Drag 64

Export 68

Fixup 64

Get 65

Import 67

Move 63

Save 66

Text Export 70

Block parts 242, 270

Block symbol

defining 328

Block symbol definitions

comments in 329

Block symbol, defining a 338

BODY command

Edit Library 242, 270, 271

<Block> 274

<Block> Kind of Part 274

<Block> Size of Body 274

<Graphic> 275

<Graphic> Arc 277

<Graphic> Circle 276

<Graphic> Circle Center 276, 277

<Graphic> Delete 281

<Graphic> Erase Body 281

<Graphic> Fill 280

<Graphic> IEEE Symbol 279

<Graphic> Kind of Part 281

<Graphic> Line 275

<Graphic> Size of Body 281

<Graphic> Text 278

<IEEE> 282

<IEEE> Circle 283

<IEEE> Delete 285

<IEEE> Erase Body 286

<IEEE> IEEE Symbol 285

<IEEE> Kind of Part 286

<IEEE> Line 282

<IEEE> Size of Body 286

<IEEE> Text 284

Block 242, 272

Graphic 243

IEEE 243

Place 273

BODY Kind of Part? 271

Border Text, character height 35

Border, worksheet

Suppressing 402

Brackets *xxviii*

Buffer

Draft

Getting and placing objects 65

Hierarchy 71, 72

Macro 71, 72

Saving objects 66

Hierarchy 27

Macro 25

- 
- button 673
  - Buttons *xxiii*
    - Arrow 5
  - byte 673
  - C**
  - Cadnetix netlist format
    - CADNETIX.CF 514
  - CAE 673
  - Calay netlist format
    - CALAY.CF 515
    - component file 515
  - Calcomp plotters 665
  - Case netlist format
    - CASE.CF 516
  - CBDS netlist format
    - CBDS.CF 518
  - CF file extension 500
  - Changing part orientations
    - Draft 86
  - Changing reference designator locations
    - Draft 83
  - Changing reference designators
    - Draft 83
  - Changing the library order 15
  - Changing the title block
    - Draft 88
  - Changing title blocks
    - Draft 89
  - Character height
    - Comment Text 35
    - Label 34
    - Module Text 34
    - Part Field 34
    - Part Reference 34
    - Part Value 34
    - Pin Name 34
    - Pin Number 34
    - Power Text 34
    - Sheet Name 34
    - Sheet Net 34
  - Character strings 352, 355
  - check box 673
  - Check Electrical Rules 381-389
    - Configuration Matrix 50
    - Default settings 385
    - Error messages 383-384
    - Execution 381
    - Force to process all sheets 389
    - Local Configuration 387
      - File Options 387
      - Processing Options 389
    - Matrix explained 383
    - Type mismatches 395
  - child 673
  - CLEANUP (*see also Cleanup Schematic*)
  - Cleanup Schematic 189-192
    - Errors, checking for 189
    - Execution 189
    - Local Configuration 191
      - File Options 191
      - Processing Options 192
    - Off-grid items 192
  - Click *xxvi*
  - Clock, computer 197
  - Color and Pen Plotter Table 28-31
    - Pen speed 30
    - Pen width 30
  - Command reference
    - Draft 58-156
    - Edit Library 268, 315
  - Comment Text
    - Character height 35
  - Compile Library 375-378
    - Creating custom libraries 240, 241
    - Creating custom libraries with 375
    - Execution 375
    - Local Configuration 376
  - Compile Simulation Specification File 461
    - configuring
  - Compiled library files 238
    - .LIB extension 238
  - Compiler, netlist (*see also: INET*)
    - INET 196

Compiling the connectivity database 193  
(*see also INET*)

Complex hierarchy 673  
    Annotate Schematic 183  
    Creating a netlist 195

Complex to Simple 195, 204

ComputerVision netlist format  
    COMPVISN.CF 519

CONDITIONS command  
    Draft 71  
    Edit Library 287

configuration 673

Configure Schematic Design Tools  
    Check Electrical Rules Matrix 50  
    Color and Pen Plotter Table 28-31  
    Driver Options 6-10  
        Available Display Drivers 8  
        Available Plotter Drivers 10  
        Available Printer Drivers 9  
        Driver Prefix 7  
    Hierarchy Options 27  
        Buffer size 27  
    Key Fields 37-49  
        Annotate Part Value Combine 40  
        Annotate Schematic 38  
        Bill of Materials  
            Include File Combine 46  
        Create Bill of Materials 38  
        Create Netlist 38  
        Extract PLD  
            PLD Part Combine 47  
            PLD Type Combine 47  
        Extract PLDs 38  
    Netlist  
        Module Value Combine 45  
        Part Value Combine 45  
    Update Field Contents  
        Combine for Fields 1 through  
            8 43  
        Combine for Value 43

Configure Schematic Design Tools  
(continued)

Library Options 12-18  
    Active library size 18  
    Configured Libraries 12-15, 16  
    Insert a Library 14  
    Library Prefix 13  
    Name Table Location 15-17  
    Remove a Library 14  
    Symbolic Data Location 15-17

Macro Options 25-26, 111

Printer Plotter Output Options 11

Template Table 32-36

Worksheet Options 19-24  
    Worksheet Prefix 23

Configured Libraries 12-15, 16

Connecting buses to module ports 162

Connecting power  
    Draft 164

Connecting signals without wires or buses  
    Draft 157

Connectivity d 204

Connectivity database *xxv*, 196, 216, 673  
    Compiling 193 (*see also INET*)  
    Digital Simulation Tools 193, 194, 206,  
        217  
    Formatting 193 (*see also IFORM and  
        HFORM*)  
    Linked 198, 199  
    Linking 193 (*see also ILINK*)  
    PC Board Layout Tools 193, 194, 206  
    Process flow for creating 195

Connectors  
    Placing, in Draft 172

Conventions *xxviii*

Convert 342-345  
    Draft 86

Convert Plot to IGES 397-399  
    Local Configuration 399  
        File Options 399  
    Sample output 398

Converted form definition  
    DeMorgan equivalent 342

Converting plots to IGES format 397-399  
Create Bill of Materials 417-424

- Adding information 421
- Execution 417
- Include file format 422
- Key Fields 419
- Local Configuration 420
  - File Options 420
  - Processing Options 423
- Merging an include file 421
- Sample output 418

Create Hierarchical Netlist 157, 215-223

- Execution 216
- INET 216
- Local Configuration 217-223

Create Netlist 157, 203-214

- Execution 204
- Key Fields 38
- Local Configuration 205-214

Creating a Bill of Materials 417-424  
Creating a bitmap definition 339-340  
Creating a graphic symbol 341  
Creating a netlist 193-201  
Creating a part 261  
Creating a part list

- Create Bill of Materials 417-424

Creating a vector definition 340  
Creating custom libraries 239-245

- with Compile Library 375
- with string files 254, 255

Cross Reference Parts 391-396

- Execution 391
- Local Configuration 392
  - File Options 393
  - Processing Options 394
- Sample output 392

cursor 673  
Custom drivers 8, 9, 10

## D

Data bits 11  
Decompile Library

- Creating custom libraries 241
- Execution 317
- Library source file 317
- Local Configuration 318
  - File Options 318
  - Processing Options 319

default 673  
Default settings

- Check Electrical Rules 385

Defining a vector 347-350  
DELETE command

- Draft 73-74
  - Block 74
  - Object 73
  - Undo 74

design cycle 674  
Design Environment *xxiii-xxvi*  
Design Management Tools

- Complex to Simple 195, 204

digital 674  
Digital Simulation Tools *xxiii, xxv*

- Annotate Schematic 183
- Connectivity database 193, 194, 206, 217
- INET, output from 196
- netlist format
  - VSTMODEL.CF 543
- Unlinked connectivity database 199

Disk full

- During Cleanup Schematic 189

Display drivers 8  
Double-click *xxvi*



*Draft xxiv, 55 (see also Draft commands)*

- Active library 72
- Adding nets to sheet symbols 79
- Changing net names on sheet symbols
- Changing net types on sheet symbols
- Changing objects 75-90
- Changing orientation of 78
  - Labels 76
  - Parts 82-87
- Changing part orientations 86
- Changing reference designator locations 83
- Changing reference designators 83, 179
- Changing size of
  - Text 75, 76
- Changing size of labels 76
- Changing style of
  - Labels 76
  - Module ports 77
  - Parts 82-87
  - Power objects 78
  - Text 75, 76
- Changing title blocks 88-89
- Changing type of
  - Module port 77
- commands
  - GET Convert 272
- Configure Schematic Design Tools 111
- Connecting buses to module ports 162
- Connecting power 164
- Connecting signals without wires or buses 157
- Connectors
  - Placing 172
- Convert 86
- Deleting nets from sheet symbols 79
- Editing
  - Label names 76
  - Labels 76
  - Layout symbols 90
  - Module ports 77
  - Net names on sheet symbols

*Draft (continued)*

- Net types on sheet symbols 81
- Objects 75-90
- Part fields 85
- Part orientations 86
- Part reference designators 82
- Part values 84
- Power objects 78
- Reference designator locations 83
- Reference designators 83
- Sheet symbols 79
- Stimulus objects 90
- Text 75, 76
- Title blocks 88-89
- Trace objects 90, 133
- Vector objects 90
- Erasing objects 73-74
- Execution 55
- Exporting objects to a file 68
- Exporting text to a file 70
- Fixing wires and buses 64
- Getting and placing objects from a buffer 65
- Hierarchy buffer 71, 72
- Importing objects from a file 67
- Importing text from a file 69
- Initial macro 26
- Isolating power 167-171
- Labeling buses 158
- Loading parts 93-96
- Local Configuration 56
  - File Options 56
  - Processing Options 57
- locating commands 58
- Locating objects 91-92
- Macro file 26
- Macros
  - Buffer 25, 71, 72, 111
  - Calling 111
  - Configure Schematic Design Tools 111
  - Creating 107-117
  - Debugging 109

## Draft (continued)

- Initial 110
- Macro Options 111
- Nesting 109
- Pause 109
- Syntax 112
- Text files 112
- Using mouse with 115
- Valid macro keys 107
- Memory 71
- Moving objects 63, 64
- Name table 72
- Orthogonal wires and buses 64
- Placing a bus 122
- Power objects 164
  - Changing name of 78
  - Changing type of 78
- Power supplies, creating different 165-166
- Power, isolating 167-171
- Reference library 72
- Repeating commands 61, 145
- Restoring deletions 74
- Rotating parts 86-87
- Saving objects in a buffer 66
- Status information, displaying 71
- Symbol table 72
- Worksheet memory 71

Draft commands 58, 73, 74-156

- AGAIN 61
- BLOCK 62-70
- BLOCK ASCII Import 69
- BLOCK Drag 64
- BLOCK Export 68
- BLOCK Fixup 64
- BLOCK Get 65
- BLOCK Import 67
- BLOCK Move 63
- BLOCK Save 66
- BLOCK Text Export 70
- CONDITIONS 71
- DELETE 73-74
- EDIT 37, 75-90

## Draft commands (continued)

- EDIT Add-Net 79
- EDIT Delete 79
- EDIT Filename 80
- EDIT Label 76
- EDIT Label Larger 76
- EDIT Label Name 76
- EDIT Label Orientation 76
- EDIT Label Smaller 76
- EDIT Module Port 77
- EDIT Module Port Name 77
- EDIT Module Port Style 77
- EDIT Module Port Type 77
- EDIT Orientation 86
- EDIT Part 41, 82
- EDIT Part Fields 85
- EDIT Part Value 84
- EDIT Power 78
- EDIT Power Name 78
- EDIT Power Orientation 78
- EDIT Power Type 78
- EDIT Reference 82
- EDIT Size 81
- FIND 91-92
- GET 16, 72, 93-96
- GET Convert 95
- GET Down 96
- GET Mirror 96
- GET Over 96
- GET Place 95
- GET Rotate 95
- GET Up 96
- HARDCOPY 97-99
- HARDCOPY Destination 98
- HARDCOPY File Mode 99
- HARDCOPY Make Hardcopy 99
- HARDCOPY Width of Paper 99
- INQUIRE 100, 382
- JUMP 101-103
- JUMP Reference 101
- JUMP X-Location 102
- JUMP Y-Location 103
- LIBRARY 104-105

Draft commands (continued)

- LIBRARY Browse 16, 105
- LIBRARY Directory 104
- MACRO 106-117
- MACRO Capture 107-110
- MACRO Delete 110
- MACRO Initialize 110
- MACRO List 110
- MACRO Read 110
- MACRO Write 111
- PLACE 118-137
  - PLACE Bus 120
  - PLACE Dashed Line 132
  - PLACE Entry (Bus) 122
  - PLACE Junction 121
  - PLACE Label 123
  - PLACE Layout 138
  - PLACE Module Port 125-126
  - PLACE No-Connect 137
  - PLACE Power 127-128
  - PLACE Sheet 129-130, 197
  - PLACE Stimulus 135-136
  - PLACE Text 131
  - PLACE Trace 133
  - PLACE Vector 134
  - PLACE Wire 118
- QUIT 141-144
  - QUIT Abandon Edits 143
  - QUIT Enter Sheet 141
  - QUIT Initialize 142
  - QUIT Leave Sheet 141
  - QUIT Run User Commands 144
  - QUIT Suspend to System 143
  - QUIT Update File 142
  - QUIT Write to File 142
- REPEAT 145
- SET 146-154
  - SET Auto Pan 147
- TAG 155
- ZOOM 156
  - ZOOM In 156
  - ZOOM Out 156

DRAFTUSR 144

Dragging buses

- Draft 148

Drawing errors

- Cleanup Schematic 189

Driver Options (*see Drivers*)

Driver Prefix 7

Drivers 6-10

- Custom drivers 8, 9, 10
- Driver Options
  - Available Display Drivers 8
  - Available Plotter Drivers 10
  - Available Printer Drivers 9
  - Driver Prefix 7
- Supported by ESP 175

E

EDA 674

EDIF Hierarchical netlist format

- EDIF.CH 571
  - pin names 571
  - pin numbers 571

EDIF netlist format

- EDIF.CF 520
  - pin names 520
  - pin numbers 520

EDIT command

- Draft 37, 75-90
  - Add-Net 79
  - Delete 79
  - Filename 80
  - Label 76
    - Label Larger 76
    - Label Name 76
    - Label Orientation 76
    - Label Smaller 76
  - Module Port 77
  - Module Port Name 77
  - Module Port Style 77
  - Module Port Type 77
  - Orientation 86
  - Part 41, 82
  - Part Fields 85

## EDIT command (continued)

- Part Value 84
  - Power 78
  - Power Name 78
  - Power Orientation 78
  - Power Type 78
  - Reference 82
  - Size 81
- Edit File *xxiv*, 173
- Execution 173
  - M2EDIT 173
- Edit Library *xxv*, 259, 314-315
- Bit map images 288
  - Changing the definition of a part 295
  - Command reference 268, 315
  - Creating parts 240
  - Editing parts 240
  - Execution 264
  - Initial macro 26
  - Library objects 288
  - Local Configuration 265
    - Fileh4 Options 265
    - Processing Options 267
  - Macro buffer 25
  - Macro file 26
  - memory 287
  - Part body 242
    - Graphic part 243
    - IEEE parts 243
  - Part name 245
  - Part pins
    - Pin name 244
    - Pin number 244
    - Pin shape 244
  - part suffix 291
  - Reference designator 245
  - Repeating commands 269
  - Sheetpath 245
  - Sheetpath designator 245
  - status information, displaying 287
  - System memory, free 288

## Edit Library commands

- AGAIN 269
- BODY 242, 270, 271, 274-286
- BODY <Block> 274
- BODY <Block> Kind of Part 274
- BODY <Block> Size of Body 274
- BODY <Graphic> 275
- BODY <Graphic> Circle 276
- BODY <Graphic> Circle Center 276, 277
- BODY <Graphic> Delete 281
- BODY <Graphic> Erase Body 281
- BODY <Graphic> Fill 280
- BODY <Graphic> IEEE Symbol 279
- BODY <Graphic> Kind of Part 281
- BODY <Graphic> Line 275
- BODY <Graphic> Size of Body 281
- BODY <Graphic> Text 278
- BODY <IEEE> 282
- BODY <IEEE> Circle 283
- BODY <IEEE> Erase Body 286
- BODY <IEEE> Kind of Part 286
- BODY <IEEE> Line 282
- BODY <IEEE> Size of Body 286
- BODY <IEEE> Text 284
- BODY Block 242, 272
- BODY Graphic 243, 272
- BODY IEEE 243
- BODY Place 273
- BODY<IEEE> Delete 285
- BODY<IEEE> IEEE Symbol 285
- CONDITIONS 287
- EXPORT 289
- GET PART 261, 291
- IMPORT 292
- JUMP 293-294
- JUMP X-Location 293
- JUMP Y-Location 294
- LIBRARY 294-300
- LIBRARY Browse 297
- LIBRARY Delete Part 298
- LIBRARY List Directory 296
- LIBRARY Prefix 299

Edit Library commands (continued)

LIBRARY Update Current 261, 295  
MACRO 301  
MACRO Initial Macro 301  
NAME 245, 302-303  
NAME Add 303  
NAME Delete 303  
NAME Edit 303  
NAME Prefix 303  
ORIGIN 304  
PIN 305-307  
PIN Add 305  
PIN Delete 305  
PIN Move 307  
PIN Name 244, 305  
PIN Pin-Number 244, 305  
PIN Shape 244, 307  
PIN Type 244, 306  
QUIT 308-310  
QUIT Abandon Edits 310  
QUIT Initialize 309  
QUIT Suspend to System 309  
QUIT Update File 261, 308  
QUIT Write to File 261, 309  
REFERENCE 311  
SET 312-313  
SET Auto Pan 312  
SET Backup File 312  
SET Error Bell 313  
SET Left Button 312  
SET Macro Prompts 313  
SET Power Pins Visible 313  
SET Show Body 273  
SET Show Body Outline 284, 313  
SET Visible Grid Dots 313  
ZOOM 315  
ZOOM Center 315  
ZOOM In 315  
ZOOM Out 315  
ZOOM Select 315

Editing in Draft

Layout symbols 90  
Part orientations 86  
Reference designator locations 83  
Reference designators 83  
Stimulus objects 90  
Title blocks 88-89  
Trace objects 90, 133  
Vector objects 90  
Editing a part 261  
editor 674  
Editors *xxiv*, 53-175  
EEDesigner netlist format  
  EEDESIGN.CF 523  
EMS 674  
EMS memory 16-18  
  Draft 71  
    Advantages and disadvantages 72  
entry box 674  
equations included in the netlist  
  AlteraADF netlist format 510  
  IntelADF netlist format 534  
ERC (*see also Check Electrical Rules*)  
  INET 208, 219  
Error bell, setting  
  Draft 148  
Error messages  
  Check Electrical Rules 383-384  
Errors, checking for  
  Cleanup Schematic 189  
ESP *xxiii-xxvi*  
EXPORT command  
  Edit Library 289  
Extensions  
  .BAK 189  
  .INF 196  
  .INS 198, 199  
  .INX 196, 197, 201  
  .LIB 238  
  .LNF 198, 199, 212  
  .PIP 198, 199  
  .RES 198, 199  
  .SRC 238

- EXTRACT 433
  - Programmable Logic Device Tools 432
  - To PLD 432, 440
- Extract PLD
  - Key Fields
    - PLD Part Combine 47
    - PLD Type Combine 47
- F
- File extensions
  - .BAK 189
  - .CF 500
  - .INF 196
  - .INS 198, 199
  - .INX 196, 197, 201
  - .LIB 238
  - .LNF 198, 199, 212
  - .PIP 198, 199
  - .RES 198, 199
  - .SRC 238
- File stack
  - Rebuilding, INET 209, 220
- File structure
  - Flat 197
  - Hierarchical 197
- FIND command
  - Draft 91-92
- flat design 674
- Flat file structure 197
- Flat formatter 200
- Flat netlist 200
- FLDSTUFF 433, 435
  - To Layout 465
- For ILINK to read .INF files, the statements must appear in the order and frequency shown in the table below. The port and signal statements can be intermingled, as can the trace, vector, and stimulus statements. 586
- Formatter
  - Flat netlist 200
  - Hierarchical 200
- Formatting a netlist 193 (*see also* IFORM and HFORM)
- FutureNet netlist format
  - FUTURE.CF 524
  - pin names 525
  - pin numbers 525
  - power attributes 526
  - symbols for module ports 525
- G
- GENDRIVE 175
- GET command
  - Draft 16, 72, 93-96
    - Convert 95
    - Down 96
    - Mirror 96
    - Over 96
    - Place 95
    - Rotate 95
    - Up 96
- GET PART command
  - Edit Library 261, 291
- Graphic parts 243, 270
  - limits 263
- Graphic symbol
  - defining 339
- Graphic symbol, defining a 345
- Grid dots 152
- Grid references 152
- Grid references, ANSI 22
- grid unit size 328
- GRIDARRAY
  - part definition 326
  - parts 331

## H

### HARDCOPY command

- Draft 97-99
  - Destination 98
  - File Mode 99
  - Make Hardcopy 99
  - Width of Paper 99

### HFORM 200

- Configuration, Create Hierarchical Netlist 217, 222-223
- File Options 222
- Processing Options 223
- Create Hierarchical Netlist 216
- Incremental connectivity database 200
- INET, output from 196

### HI plotters 665

### hierarchical design 674

### Hierarchical file structure 197

### Hierarchical formatter 200

### Hierarchical netlist 200, 203

- Creating 215

### hierarchical netlist formats 566-580

### Hierarchy Options 27

- Buffer size 27

### Highlight *xxvi*

### HiLo netlist format

- HILO.CF 530

### hotpoint 124, 159

### HP plotters 664

## I

### IBUILD

- To Digital Simulation 459

### IEEE

- Body Outline 349
- Pin placement 349
- size limits 348

### IEEE parts 243, 261, 270, 271, 272, 331

### IEEE symbol

- definition of 346-350

### IFORM 198

- Configuration, Create Netlist 205, 213-214
- File Options 213
- Processing Options 214
- ILINK, from 200
- ILINK, output from 198
- Intermediate netlist structure 200

### IGES

- Converting plots to IGES format 397-399

### ILINK 198

- Configuration, Create Netlist 205, 211-212
- File Options 211
- Processing Options 212

### IFORM, to 198

### INET, output from 196

### INS file 198, 199

### PC Board Layout Tools, to 198

### PIP file 198

### RES file 198, 199

### To Layout 476

### IMPORT command

- Edit Library 292

### Incremental annotation 184

### Incremental connectivity database (*see connectivity database*), 196, 674

### Incremental design 193

### incremental netlisting 674

### INET 194, 196-198, 201

- Configuration, Create Hierarchical Netlist 217

- File Options 218

- Processing Options 219

- Configuration, Create Netlist 205, 207, 218

- File Options 207

- Processing Options 208

### Connectivity database 196

### Create Hierarchical Netlist 216

### Create Netlist 204

### Digital Simulation Tools, to 196

INET (continued)  
 HFORM, to 196  
 ILINK, to 196  
 INF file 196  
 INX file 196, 197  
 Time stamp, comparing 196  
 To Digital Simulation 455  
 To Layout 472  
 INF file 196  
 Initial macro 26, 674  
 INQUIRE command  
 Draft 100, 382  
 INS file 198, 199  
 Inserting a library 14  
 Instance file (INS) 199  
 IntelADF netlist format  
 header information 532  
 including equations in the netlist 534  
 INTELADF.CF 532  
 suppressing comments in the netlist  
 532  
 Intergraph netlist format  
 INTERGRA.CF 536  
 intermediate netlist structure 198, 199, 674  
 INX file 196, 197, 201  
 Isolating power  
 Draft 167-171

## J

JUMP command  
 Draft 101-103  
 Reference 101  
 X-Location 102  
 Y-Location 103  
 Edit Library 293  
 X-Location 293  
 Y-Location 294

## K

K 675  
 key field 675  
 Key Fields 37-49, 180 (*see also: Configure Schematic Design Tools*), 435  
 Annotate Part Value Combine 40  
 Annotate Schematic 38  
 Bill of Materials  
 Include File Combine 46  
 Create Bill of Materials 38, 419  
 Create Netlist 38  
 Extract PLD  
 PLD Part Combine 47  
 PLD Type Combine 47  
 Extract PLDs 38  
 Netlist  
 Module Value Combine 45  
 Part Value Combine 45  
 netlist formats 500  
 Update Field Contents 38, 232  
 Combine for Fields 1 through 8 43  
 Combine for Value 43  
 Keyboard commands 5  
 Keyboard equivalents xxvii  
 Keywords 353, 355

## L

Labeling buses  
 Draft 158  
 Labels  
 Character height 34  
 Connected, reporting 208, 219  
 Layout directives 138  
 Layout symbols  
 Draft  
 Editing 90  
 LIB file 238  
 librarian 675  
 Librarians xxv, 235-378



Libraries 12-18

- Active library 16
- Changing the library order 15
- Configured 12-15, 16
- Inserting a library 14
- Library Options
  - Active library size 18
  - Configured Libraries 12-15, 16
  - Insert a Library 14
  - Library Prefix 13
  - Name Table Location 15-17
  - Remove a Library 14
  - Symbolic Data Location 15-17
- Removing a library 14

Library 675

- Parts found in each library 175

LIBRARY command

- Draft 104-105
  - Browse 16, 105
  - Directory 104
- Edit Library 294
  - Browse 297
  - Delete Part 298
  - List Directory 296
  - Prefix 299
  - Update Current 261, 295

Library files 237

- Compiled 238
  - .LIB extension 238
- Order Searched 239
- Source
  - .SRC extension 238
- Source file 238

Library objects

- Edit Library 288

Library Options (*see Libraries*)

Library Prefix 13

library size 264

Library source file 321

- Decompile Library 317

Library source files 238

- .SRC extension 238

Linked connectivity database 198, 675

- Producing 212

Linked netlist 215

- Creating 203-214

Linker, netlist 198

Linking the connectivity database 193 (*see also ILINK*)

List box 5

List Library 239, 247-250

- Execution 247
- Local Configuration 248
  - File Options 249
  - Processing Options 250
- Sample report 248
- String files 250

Listing part names 247 (*see also: List Library*)

LNf file 198, 199, 212

Loading parts

- Draft 93-96

Local Configuration 675

- Compile Simulation Specification

Local Configuration of ASCTOVST 460

Locating objects

- Draft 91-92

Locating parts 104, 105

## M

M2EDIT 173, 175

- Edit File 173

- View Reference Material 175

macro 675

MACRO command

- Draft 106-117
  - Capture 107-110
  - Delete 110
  - Initialize 110
  - List 110
  - Read 110
  - Write 111

Edit Library 301

- Initial Macro 301

## Macros

- Buffer 25
  - Draft
    - Buffer 71, 72, 111
    - Calling 111
    - Creating 107-117
    - Debugging 109
    - Initial 110
    - Nesting 109
    - Pause 109
    - Syntax 112
    - Text files 112
    - Using mouse with 115
    - Valid macro keys 107
  - Edit Library
    - Buffer 288
  - Enabling Prompts 149
  - File 26
  - Initial 26
  - Macro Options 25-26
- Main menu commands *xxviii*
- Match string 43
- MB 675
- megabyte 675
- Memory
  - Draft 71
- Memory, EMS
  - Draft
    - Advantages and disadvantages 72
- Mentor netlist format
  - component file 537
  - MENTOR.CF 537
- Module port 675
  - Character height 34
- Module ports
  - Connections, checking 209, 220
  - Unconnected, reporting 208, 219
- Mouse *xxvi*
  - Buttons *xxvi*
- MultiWire netlist format
  - MULTIWIR.CF 538

## N

- NAME command
  - Edit Library 245, 302
    - Add 303
    - Delete 303
    - Edit 303
    - Prefix 303
- Name table
  - Draft 72
- Name Table Location 15-17
- net 675
- Netlist 675
  - Compiler (*see also: INET*)
    - INET 196
  - Creating 193-201
    - Flat 200
      - Many sheets 196
      - One-sheet 196
    - Flattened 203
    - Formatter 200
    - Hierarchical 200, 203
      - Complex 196
      - Creating 215
      - Simple 196
    - Linked 203, 215
      - Creating 203-214
    - Linker 198
      - Structure, intermediate 198, 199
  - netlist formats 506-580
    - key fields 500
  - Netlister, incremental 204, 216
  - Notation *xxviii*
  - Numeric constants 352, 355
- O
- Off-grid parts
  - Reporting 208, 219
- OrCAD Digital Simulation Tools
  - netlist format
    - including text in the netlist 543
    - VSTMODEL.CF 543

OrCAD Programmable Logic Design Tools

netlist format

PLDNET.CF 541

OrCAD/PCB II

netlist format

PCBII.CF 539

ORIGIN command

Edit Library 304

Orthogonal wires and buses 64

Drawing 149

**P**

package 676

PADS ASCII netlist format

PADSASC.CF 545

part list file 545

pan 676

parent 676

Parity 11

part 676

limits 263

Part Body 242

Block part 242

Graphic part 243

IEEE parts 243

Part definition 325-327

Components of 325

Construction 325

types of 325

Part Field 676

Character height 34

Part Fields *xxv*

Select Field View 226

Part list, creating

Create Bill of Materials 417-424

Part name 245

part name string 328, 346

Part pins 244

Pin name 244

Pin number 244

Pin shape 244

Part Reference

Character height 34

part suffix

Edit Library 291

Part Value

Character height 34

parts per package 272, 328

Parts, connected

Reporting 208

PC Board Layout Tools 138, 157

Connectivity database 193, 194, 206

ILINK, output from 198

Linked connectivity database 199, 212

LNF file 198

PCAD netlist format

PCAD.CF 547

PCADnlt netlist format

PCADNLT.CF 550

PCB 675

PCB II, OrCAD

netlist format

PCBII.CF 539

Pen speed 30

Pen width 30

PIN command

Edit Library 305, 308

Add 305

Delete 305

Move 307

Name 244, 305

Pin-number 244, 305

Shape 244, 307

Type 244, 306

Pin definition 326-327

Pin Name 244

Character height 34

pin names

EDIF hierarchical netlist format 571

EDIF netlist format 520

FutureNet netlist format 525

Pin Number 244

Character height 34

- pin numbers
  - EDIF hierarchical netlist format 571
  - Edif netlist format 520
  - FutureNet netlist format 525
- Pin shape 244
- Pins
  - Unconnected, reporting 208, 219
- PIP file 198, 199
- Pipe commands 196, 199(*see also: Pipe link*)
- Pipe link 197
- PLACE command
  - Draft 118-137
    - Bus 120
    - Dashed Line 132
    - Entry (Bus) 122
    - Junction 121
    - Label 123
    - Layout 138
    - Module Port 125-126
    - No-Connect 137
    - Power 127-128
    - Sheet 129-130, 197
    - Stimulus 135-136
    - Text 131
    - Trace 133
    - Vector 134
    - Wire 118
- Placing a bus
  - Draft 122
- Placing connectors
  - Draft 172
- Plot Schematic 401-410
  - Execution 401
  - Local Configuration 404
    - File Options 404
    - Processing Options 407
  - Plotting to a file 405
  - Plotting to a printer 405
  - Sample output 403
  - Scaling plots
  - Setting offsets 410
  - Suppressing the title block, border,  
and text 402
- plotter
  - cabling 658
  - Calcomp 665
  - DXF driver for AutoCAD 671
  - HI 665
  - hints 663
  - HP 664
  - HP driver 669
  - HP LaserJet driver 670
  - MODE command 661
  - PC/AT cabling 659
  - PC/XT cabling 658
  - PC/XT cabling for IOLine plotters 659
  - problems 660
- Plotters (*see printers and plotters*)
- Plotting
  - Plot Schematic 401-410
    - To a printer 662
- Plotting to a file
  - Plot Schematic 405
- Plotting to a printer
  - Plot Schematic 405
- Point xxvi
- pointer 676
- Power objects
  - Draft 164
- Power supplies, creating different
  - Draft 165-166
- Power Text
  - Character height 34
- Power, isolating
  - Draft 167-171
- Prefix definition
  - Construction 323
  - Symbol Description Language 356
- Print Schematic 411-415
  - Execution 411
  - Local Configuration 413
    - File Options 414
    - Processing Options 415
  - Sample output 412
  - Suppressing pin numbers 415
- Printed Circuit Board Layout Tools xxiii

Printers and plotters 11  
  Plotter drivers 10  
  Plotters 11  
  Printer drivers 9  
  Printer/Plotter Output Options 11  
  Printers 11  
Printing  
  Print Schematic 411-415  
Printing to a file  
  Print Schematic 414  
Prints  
  how to scale 405  
  processor 676  
  Processor switches 481  
  Processors *xxv*, 177-234  
Programmable Logic Design Tools *xxiii*,  
  431  
  netlist format  
    PLDNET.CF 541  
  programmable logic device 676  
Programmable Logic Device Tools  
  To PLD  
    EXTRACT 432  
    work screen 433  
prompt 676

## Q

quiet mode 676  
QUIT command  
  Draft 141-144  
    Abandon Edits 143  
    Enter Sheet 141  
    Initialize 142  
    Leave Sheet 141  
    Run User Commands 144  
    Suspend to System 143  
    Update File 142  
    Write to File 142

QUIT command (continued)  
  Edit Library  
    Abandon Edits 310  
    Initialize 309  
    Suspend to System 309  
    Update File 261, 308  
    Write to File 261, 309  
Quotation marks *xxviii*

## R

RacalRedac netlist format  
  component file 551  
  RACALRED.CF 551  
radio button 676  
REFERENCE command  
  Edit Library 311  
Reference designator 245, 328, 330  
  location of 330  
Reference designators *xxv*, 179  
Reference library  
  Draft 72  
Reference material 175  
Referencing sheetpath parts 329  
Removing a library 14  
REPEAT command  
  Draft 145  
Repeating Draft commands 61, 145  
Repeating Edit Library commands 269  
reporter 676  
Reporters *xxv*, 379-427  
RES file 198, 199  
Resolved file (RES) 199  
root directory 677  
root sheet 677  
Rotating parts  
  Draft 86-87

## S

Scaling plots

Plot Schematic 409

scaling prints 405

schematic 677

Schematic Design Tools *xxiii*

Schematic Design Tools includes seven

Processors that read, modify, and then  
rewrite the design database.

Processors generally do not create  
human-readable reports, but rather  
create or modify database  
information. 177

Scicards netlist format

SCICARDS.CF 553

scroll buttons 677

Select Field View 37, 225-227

Execution 225

Local Configuration 225

File Options 226

Processing Options 226

Part Fields 226

SET command

Draft 146-154

Auto Pan 147

Backup File 147

Drag Buses 148

Error Bell 148

Grid Parameters 152

Left Button 148

Macro Prompts 149

Orthogonal 149

Repeat Parameters 153

Show Pin Numbers 150

Visible Lettering 154

Worksheet Size 151

X,Y Display 151

Edit Library 312

Auto Pan 312

Backup File 312

Error Bell 313

Left Button 312

SET command (continued)

Macro Prompts 313

Power Pins Visible 313

Show Body 273

Show Body Outline 284, 313

Visible Grid Dots 313

Setting offsets

Plot Schematic 410

Show Schematic Structure

Sample output 425

sheet 677

Sheet Name

Character height 34

Sheet Net 677

Character height 34

sheet part 677

Sheet size

American 32

International Standards Organization  
32

Sheet symbols

Draft

Adding nets 79

Changing net names 81

Changing types 81

Deleting nets 79

Editing

net names 81

net types

Sheetpath designator 245

sheetpath part 677

Sheetpath parts

Archive Parts in Schematic 255

Edit Library 245

part definitions 325

referencing 329

Show Schematic Structure 425

Execution 425

File Options 427

Local Configuration 426

Processing Options 427

simple hierarchy 677

- Size limits
  - Graphic parts 321
- Spacebar *xxvii*
- Spacing ratio 36
- SPICE hierarchical netlist format
  - .MAP file 578
  - .SUBCKT definitions 578
  - including text in the netlist 577
  - model node index 578
  - node names 576
  - SPICE.CH 576
- SPICE netlist format 199
  - .MAP file 556
  - including text in the netlist 555
  - node names 554
  - SPICE.CF 554
- SRC file 238
- Stimulus objects
  - Draft
    - Editing 90
- Stop bits 11
- String files
  - Archive Parts in Schematic 254
  - List Library 250
- sub-part 677
- Suppressing pin numbers
  - Print Schematic 415
- Suspending to operating system
  - Draft 144
- switches
  - Processors 481
- Symbol Description Language
  - Character strings 352, 355
  - comments in 359
  - Defining bitmaps in 368-370
    - maximum size 369
  - Defining Converts in 373-374
  - Defining parts in 358-361
  - Defining pins in 362-367
  - Defining vectors in 371-372
  - Keywords 353, 355
  - Numeric constants 352, 355
  - Prefix definition 356
- Symbol size 326
- Symbol table
  - Draft 72
- Symbolic Data Location 15-17
  - syntax 677
- Syntax diagrams
  - How to read 351-354
- System memory, free
  - Edit Library 288
- T**
- tag 678
- TAG command
  - Draft 155
  - Edit Library 314
- Tango netlist format
  - TANGO.CF 558
- Telesis netlist format
  - TELESIS.CF 507, 561
- Template Table 21, 32-36, 410
- Text editor
  - Creating a library source file 240
- text export 678
- text import 678
- text included in the netlist
  - SPICE.CF 555
  - SPICE.CH 577
  - VSTMODEL.CF 543
- Time stamp
  - INET comparing 196
- Title block 22
  - ANSI 21
  - Character height 35
  - Suppressing 402
- To Digital Simulation *xxv-cdlx*
  - ANNOTATE 452
  - IBUILD 459
  - INET 455
  - Local Configuration 451

To Layout 463-477  
    ANNOTATE 469  
    Execute 464  
    FLDSTUFF 465  
    ILINK 476  
    INET 472  
    Local Configuration 464  
To Main 479  
To PLD 431-447  
    ANNOTATE 437  
    Execution 432  
    EXTRACT 432, 440  
    Local Configuration 433  
tool 678  
Tool set *xxiii*, 678  
Trace objects in Draft  
    Editing 90, 133  
transfer 678  
Transfers *xxv*, 429-479  
    To Digital Simulation  
    To Layout 463-477  
    To Main 479  
TTL 678  
Type mismatches  
    Check Electrical Rules 395

**U**

Unconditional annotation 184  
Update Field Contents 229-234  
    Execution 229  
    Key fields 232  
    Local Configuration 231  
        File Options 232  
        Processing Options 232  
    Part Fields 232  
    Update file 229, 232  
Update Field Contents Combine 435  
Update file 229, 232  
Updating reference designators 179  
upload 678  
user button 678  
User buttons *xxvi*

**V**

vector 260, 678  
Vector definition 327  
Vector objects  
    Draft  
        Editing 90  
vector-drawn parts 273  
Vectron netlist format  
    part list file 562  
    VECTRON.CF 562  
View Reference Material 175  
    Execution 175  
    M2EDIT 175  
VSTMODEL.CF 543  
    including text in the netlist 543

**W**

Was/Is file 185, 186  
wildcard 678  
WireList netlist format  
    Wirelist.cf 563  
Wires reporting unconnected, reporting  
    208, 219  
worksheet 678  
Worksheet border, suppressing 402  
Worksheet dimensions 32  
Worksheet Options 19-24  
    Worksheet Prefix 23  
Worksheet prefix 23  
Worksheet size 408  
Worksheet size, setting 151

**Z**

zero parts per package 334  
zoom 678  
ZOOM command  
    Draft 156  
    Edit Library 315  
    Select 315





**OrCAD<sup>®</sup>**

